



VATERRA™

1969 CHEVROLET® CAMARO® SS™

OWNER'S MANUAL
BEDIENUNGSANLEITUNG
MANUEL DE L'UTILISATEUR
MANUALE DELL'UTENTE



NOTICE

All instructions, warranties and other collateral documents are subject to change at the sole discretion of Horizon Hobby, Inc. For up-to-date product literature, visit www.horizonhobby.com and click on the support tab for this product.

MEANING OF SPECIAL LANGUAGE

The following terms are used throughout the product literature to indicate various levels of potential harm when operating this product:

NOTICE: Procedures, which if not properly followed, create a possibility of physical property damage AND a little or no possibility of injury.

CAUTION: Procedures, which if not properly followed, create the probability of physical property damage AND a possibility of serious injury.

WARNING: Procedures, which if not properly followed, create the probability of property damage, collateral damage, and serious injury OR create a high probability of superficial injury.



WARNING: Read the ENTIRE instruction manual to become familiar with the features of the product before operating. Failure to operate the product correctly can result in damage to the product, personal property and cause serious injury.

This is a sophisticated hobby product and NOT a toy. It must be operated with caution and common sense and requires some basic mechanical ability. Failure to operate this Product in a safe and responsible manner could result in injury or damage to the product or other property. This product is not intended for use by children without direct adult supervision. Do not use with incompatible components or alter this product in any way outside of the instructions provided by Horizon Hobby, Inc. This manual contains instructions for safety, operation and maintenance. It is essential to read and follow all the instructions and warnings in the manual, prior to assembly, setup or use, in order to operate correctly and avoid damage or serious injury.

AGE RECOMMENDATION: Not for children under 14 years. This is not a toy.

REGISTER YOUR VATERRA PRODUCT ONLINE

Register your vehicle now and be the first to find out about the latest option parts, product updates and more. Click on the Support tab at WWW.VATERRARC.COM and follow the product registration link to stay connected.

SAFETY PRECAUTIONS AND GUIDELINES

- » Always keep a safe distance in all directions around your model to avoid collisions or injury. This model is controlled by a radio signal subject to interference from many sources outside your control. Interference can cause momentary loss of control.
- » Always operate your model in open spaces away from full-size vehicles, traffic and people.
- » Always carefully follow the directions and warnings for this and any optional support equipment (chargers, rechargeable battery packs, etc.).
- » Always keep all chemicals, small parts and anything electrical out of the reach of children.
- » Always avoid water exposure to all equipment not specifically designed and protected for this purpose. Moisture causes damage to electronics.
- » Never place any portion of the model in your mouth as it could cause serious injury or even death.
- » Never operate your model with low transmitter batteries.

WATER-RESISTANT VEHICLE WITH WATERPROOF ELECTRONICS //////////////////////////////////////

Your new Horizon Hobby vehicle has been designed and built with a combination of waterproof and water-resistant components to allow you to operate the product in many “wet conditions”, including puddles, creeks, wet grass, snow and even rain.

While the entire vehicle is highly water-resistant, it is not completely waterproof and your vehicle should NOT be treated like a submarine. The various electronic components used in the vehicle, such as the Electronic Speed Control (ESC), servo(s) and receiver are waterproof, however, most of the mechanical components are water-resistant and should not be submerged.

Metal parts, including the bearings, hinge pins, screws and nuts, as well as the contacts in the electrical cables, will be susceptible to corrosion if additional maintenance is not performed after running in wet conditions. To maximize the long-term performance of your vehicle and to keep the warranty intact, the procedures described in the “Wet Conditions Maintenance” section to follow must be performed regularly if you choose to run in wet conditions. If you are not willing to perform the additional care and maintenance required, then you should not operate the vehicle in those conditions.



CAUTION: Failure to exercise caution while using this product and complying with the following precautions could result in product malfunction and/or void the warranty.

GENERAL PRECAUTIONS

- » Read through the wet conditions maintenance procedures and make sure that you have all the tools you will need to properly maintain your vehicle.
- » Not all batteries can be used in wet conditions. Consult the battery manufacturer before use. Caution should be taken when using Li-Po batteries in wet conditions.
- » Most transmitters are not water-resistant. Consult your transmitter’s manual or the manufacturer before operation.
- » Never operate your transmitter or vehicle where lightning may be present.
- » Do not operate your vehicle where it could come in contact with salt water (ocean water or water on salt-covered roads), contaminated or polluted water. Salt water is very conductive and highly corrosive, so use caution.
- » Even minimal water contact can reduce the life of your motor if it has not been certified as water-resistant or waterproof. If the motor becomes excessively wet, apply very light throttle until the water is mostly removed from the motor. Running a wet motor at high speeds may rapidly damage the motor.
- » Driving in wet conditions can reduce the life of the motor. The additional resistance of operating in water causes excess strain. Alter the gear ratio by using a smaller pinion or larger spur gear. This will increase torque (and motor life) when running in mud, deeper puddles, or any wet conditions that will increase the load on the motor for an extended period of time.

WET CONDITIONS MAINTENANCE

- » Drain any water that has collected in the tires by spinning them at high speed. With the body removed, place the vehicle upside down and pull full throttle for a few short bursts until the water has been removed.



CAUTION: Always keep hands, fingers, tools and any loose or hanging objects away from rotating parts when performing the above drying technique.

- » Remove the battery pack(s) and dry the contacts. If you have an air compressor or a can of compressed air, blow out any water that may be inside the recessed connector housing.
- » Remove the tires/wheels from the vehicle and gently rinse the mud and dirt off with a garden hose. Avoid rinsing the bearings and transmission.

NOTICE: Never use a pressure washer to clean your vehicle.

- » Use an air compressor or a can of compressed air to dry the vehicle and help remove any water that may have gotten into small crevices or corners.
- » Spray the bearings, drive train, fasteners and other metal parts with a water-displacing light oil. Do not spray the motor.
- » Let the vehicle air dry before you store it. Water (and oil) may continue to drip for a few hours.
- » Increase the frequency of disassembly, inspection and lubrication of the following:
 - Front and rear axle hub assembly bearings.
 - All transmission cases, gears and differentials.
 - Motor—clean with an aerosol motor cleaner and re-oil the bearings with lightweight motor oil.

INTRODUCTION

Few cars have captured the American spirit like the 1969 Camaro SS. Designed in response to the Mustang in 1967, the '69 incorporated refinements to the front end, sharper body lines and new detailing inside and out that distinguished it from the earlier models. With 350 and 396 cubic inch engine options, drivers selected the factory SS package for one reason; MORE POWER! Even today, a '69 SS turns heads at car shows, cruise nights and anywhere else a love for big-displacement, Detroit power endures.

The SS bloodline is apparent in this 1/10-scale recreation of the 1969 Camaro SS. Much like its full size counterpart, this Camaro is all about power with its monster 3300Kv brushless motor and 2S Li-Po. It comes completely assembled and ready-to-run, but before hitting the road you must take a little time and read this manual. In its pages you'll find helpful setup and charging tips as well as a handy troubleshooting guide. It's all here to make sure your experience at the wheel is the best it can be.

- 6** Introduction
- 6** Quick Start
- 7** Components
- 8** The Vehicle Battery
- 9** The Transmitter
- 11** Transmitter and Receiver Binding
- 11** Control Test
- 12** Run Time
- 12** Tuning, Adjusting & Maintaining Your Vehicle
- 13** Dynamite Tazer Waterproof 45A Sensorless Brushless ESC
- 15** Dynamite Tazer 3300Kv 4-Pole Brushless Motor
- 16** Troubleshooting Guide
- 17** Limited Warranty
- 19** FCC Information
- 19** Compliance Information for the European Union
- 67** Fasteners
- 68** Replacement Parts
- 81** Optional Parts

Please read the entire manual to gain a full understanding of the V100 sedan, fine-tuning the setup, and performing maintenance.

- 1** Read the safety precautions found in this manual.
- 2** Charge the battery. Refer to the included charging warnings and instructions for battery charging information.
- 3.** Install the AA batteries in the transmitter. Only use alkaline or rechargeable batteries.
- 4** Install the fully charged battery in the vehicle.
- 5** Power ON the transmitter and then the vehicle. Always power the transmitter ON before the vehicle and power it OFF after the vehicle has been powered OFF.
- 6** Check the steering and throttle control directions. Verify that the servos are moving in the correct direction.
- 7** Drive your vehicle.
- 8** Perform any necessary maintenance.

COMPONENTS

- » 1/10-scale V100 RTR Sedan
- » Spektrum™ DX2E 2.4GHz DSM® Radio System
- » Dynamite® Tazer™ Waterproof 45A Sensorless Brushless ESC
- » Dynamite Tazer 3300Kv 4-Pole Brushless Motor
- » Vatera™ 113WP Standard Waterproof Servo
- » Dynamite Speedpack™ Silver 2S 7.4V 3000mAh 20C Li-Po Battery
- » Dynamite 10W Li-Po AC Balance Charger
- » 4 AA Batteries (for transmitter)

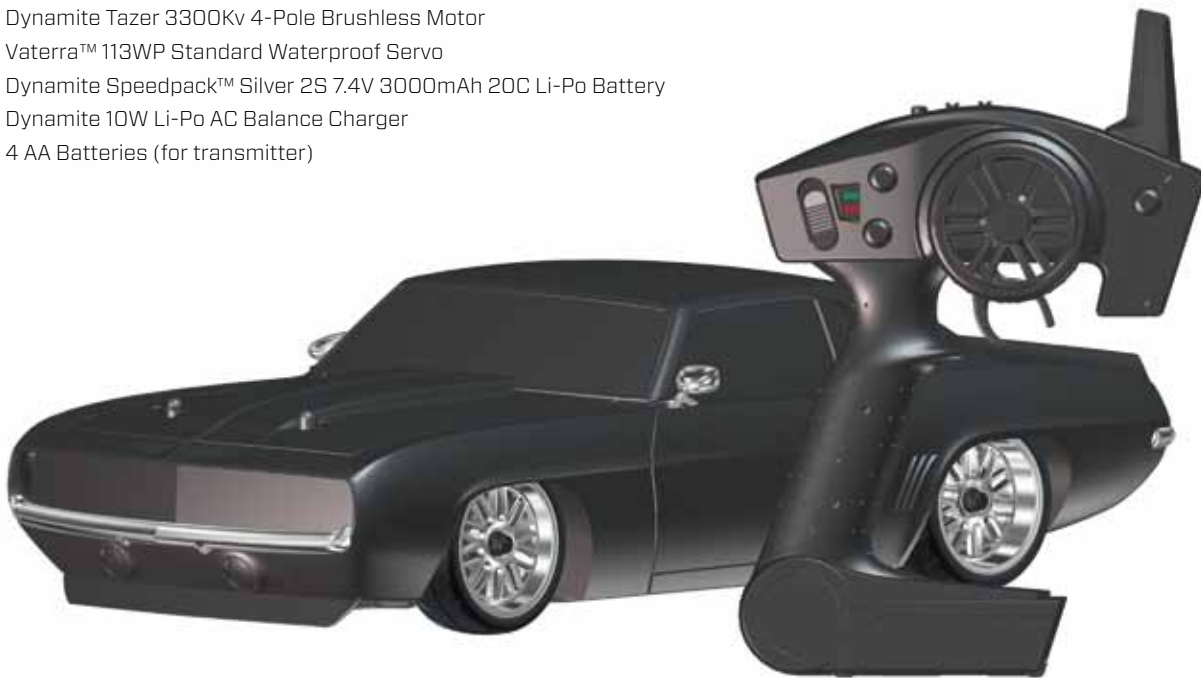

SUPPLIED TOOLS



- » 3 “L” shaped hex wrenches
 - 1.5mm, 2mm, 2.5mm



- » 4-way wrench
 - 7mm, 5.5mm, 5mm, 4.5mm

REQUIRED TOOLS

- » Hobby-grade knife
- » Needle nose pliers
- » Side cutting pliers
- » Safety goggles
- » Soldering iron
- » Soft brush

Use only Dynamite tools or other high-quality tools. Use of inexpensive tools can cause damage to the small screws and parts used on this type of model.

THE VEHICLE BATTERY

⚠ WARNING: Failure to exercise caution while using this product and comply with the following warnings could result in product malfunction, electrical issues, excessive heat, FIRE, and ultimately injury and property damage.

⚠ WARNING: Never leave charger unattended, exceed maximum charge rate, charge with non-approved batteries or charge batteries in the wrong mode. Failure to comply may result in excessive heat, fire and serious injury.

⚠ CAUTION: Always ensure the battery you are charging meets the specifications of this charger and that the charger settings are correct. Not doing so can result in excessive heat and other related product malfunctions, which can lead to user injury or property damage. Please contact Horizon Hobby or an authorized retailer with compatibility questions.

The included charger can charge the included 2S 3000mAh Li-Po battery in approximately 2.2 hours.

CHARGING WARNINGS

- » Never leave the charger and battery unattended during use.
- » Never attempt to charge dead, damaged or wet battery packs.
- » Never attempt to charge a battery pack containing different types of batteries.
- » Never allow children under 14 years of age to charge battery packs.
- » Never charge batteries in extremely hot or cold places or place in direct sunlight.
- » Never charge a battery if the cable has been pinched or shorted.
- » Always monitor the charging area and have a fire extinguisher available at all times.
- » Always end the charging process if the battery becomes hot to the touch or starts to change form (swell) during the charge process.
- » Always disconnect the battery after charging, and let the charger cool between charges.
- » Always charge in a well-ventilated area.
- » Always terminate all processes and contact Horizon Hobby if the product malfunctions.
- » Never connect more than one battery pack to this charger at a time.
- » Never connect the charger if the power cable has been pinched or shorted.
- » Never attempt to dismantle the charger or use a damaged charger.
- » Never reverse the positive and negative terminals.
- » Always use only rechargeable batteries designed for use with this type of charger.
- » Always inspect the battery before charging.
- » Always keep the battery away from any material that could be affected by heat.

CHARGING THE BATTERY

- A Cell 1 LED
- B Cell 2 LED
- C Cell 3 LED
- D AC Power Slot
- E 2S Charge Port
- F 3S Charge Port

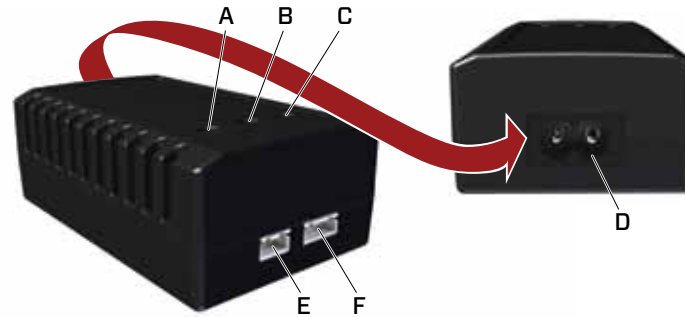

- 1 Connect the AC power cord to the AC power slot (D) on the charger, then connect the other end of the power cord to an AC power source.
- 2 The three LEDs will turn green when the charger is connected to the AC power source.
- 3 Connect the balance connector of the battery to the proper charge port on the charger (the 3S Charge Port (F) has 4 pins and the 2S Charge Port (E) has 3 pins).
- 4 The three LEDs will turn red, indicating the battery is charging.
- 5 When the charging of one cell is complete, the corresponding LED turns green.
- 6 Once the battery pack is fully charged, all three LEDs will turn green.
- 7 Disconnect the battery from the charger.
- 8 Disconnect the AC power cord from the AC power source.

INSTALLING THE VEHICLE BATTERY

- 1 Ensure the ESC is powered OFF.
- 2 Remove the body from the chassis.
- 3 Remove the body clip from the battery strap, then lift the back of the battery strap. The battery strap will rotate toward the front of the car.
- 4 Install the fully charged battery in the battery cavity.
- 5 Connect the battery to the ESC.
- 6 Lower the battery strap and secure it using the body clip.
- 7 Power ON the transmitter, then the vehicle.
- 8 Replace the body on the chassis.



THE TRANSMITTER

INSTALLING THE TRANSMITTER BATTERIES

- 1 Push in the battery cover a small amount to release the retaining tab, then remove the cover.
- 2 Install 4 AA batteries, taking care to align the battery polarity to the diagram in the transmitter's battery case.
- 3 Carefully reinstall the battery cover by aligning the tabs with the slots on the transmitter.

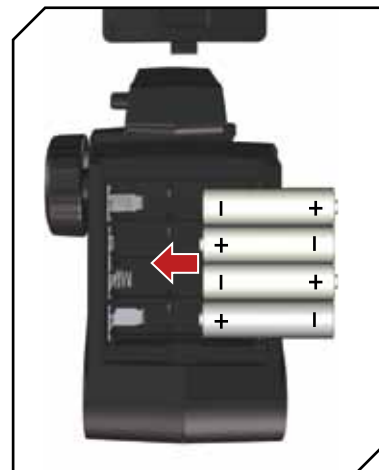

CAUTION: NEVER remove the transmitter batteries while the vehicle is powered ON, as loss of control, property damage or injury may result.

CAUTION: If using rechargeable batteries, charge only rechargeable batteries. Charging non-rechargeable batteries may cause the batteries to burst, resulting in injury to persons and/or damage to property.

For more information on the transmitter, go to www.horizonhobby.com and click on the support tab for the Spektrum DX2E to download the instruction manual.

CHANGING THE RF MODE

The DX2E has a France RF Mode that complies with French regulations. The DX2E must be in France mode when used outdoors in France. At all other times, the transmitter should be in Standard mode.

France mode ON

Turn the wheel full left, pull the trigger full throttle and hold down the bind button while turning on the transmitter. The green LED will flash twice.

France mode OFF (Standard Mode)

Turn the wheel full right, pull the trigger full throttle and hold down the bind button while turning on the transmitter. The green LED will flash once.

SPEKTRUM DX2E RADIO SYSTEM

- 1 Steering Wheel** controls direction (left/right) of the model
- 2 Throttle Trigger** controls speed and direction (forward/brake/reverse) of the model
- 3 Antenna** transmits the signal to the model
- 4 ON/OFF Switch** turns the power ON/OFF for the transmitter
- 5 Indicator Lights**
 - *Solid green light* indicates adequate battery power
 - *Flashing green light* indicates the battery voltage is critically low. Replace batteries.
- 6 ST. Trim** adjusts the “hands off” direction of the model
- 7 TH. Trim** adjusts the motor speed to stop at neutral
- 8 Steering Dual Rate** adjusts the amount the front wheels move when the steering wheel is turned left and right
- 9 BIND Button** puts the transmitter into Bind Mode
- 10 ST. REV** reverses the function of the steering when the wheel is turned left or right
- 11 TH. REV** reverses the function of the speed control when pulled back or pushed forward

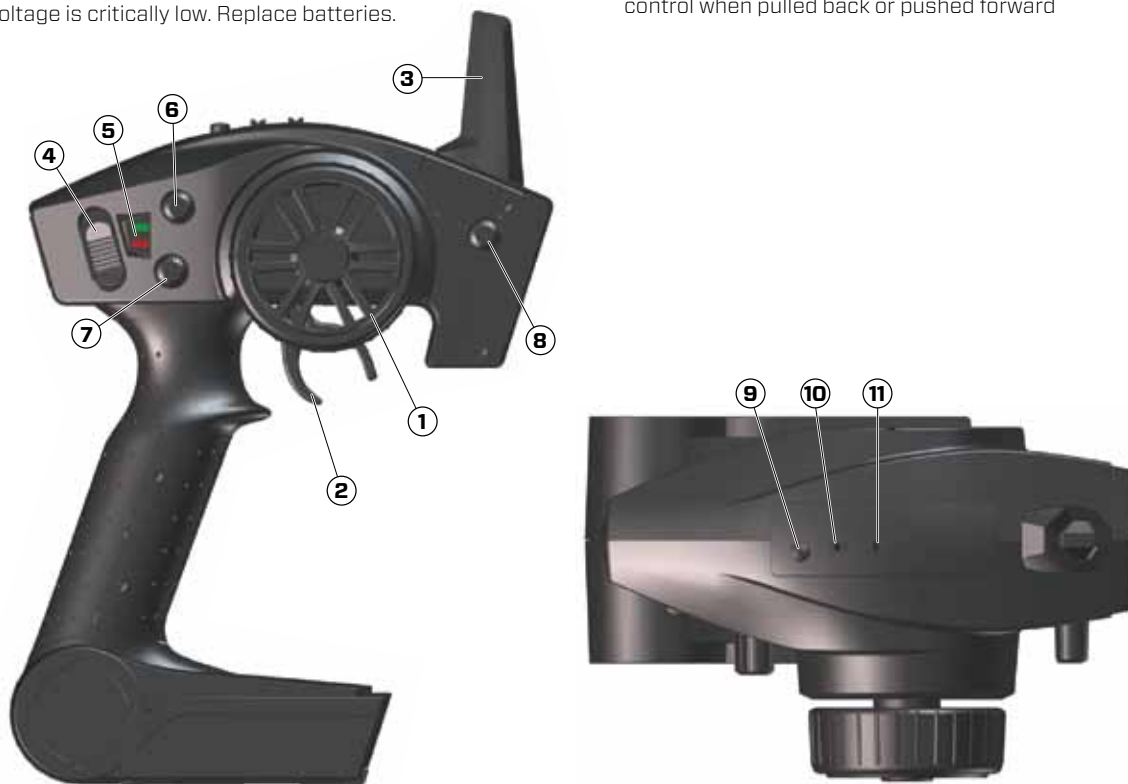

TRANSMITTER AND RECEIVER BINDING

BINDING PROCEDURE

- 1 Make sure the transmitter and vehicle are both powered OFF.
- 2 Install a bind plug in the receiver battery/bind port. You do not need to remove any of the other plugs to re-bind.
- 3 With the bind plug installed, power ON the vehicle. The receiver LED will flash green.
- 4 Move the steering wheel and throttle trigger to the failsafe positions and continue to hold those positions until the binding process is complete.
- 5 Press the bind button on the transmitter while powering on the transmitter. The green LED on the transmitter will flash after 4 seconds when the transmitter is in bind mode.
- 6 Release the bind button after the red LED on the transmitter flashes. Continue holding the failsafe positions until the receiver LED is solid. The green LED on the receiver will glow solid when the transmitter and receiver are bound.
- 7 Disconnect the battery from the ESC. Remove the bind plug from the receiver. The receiver will keep the binding to the transmitter until another binding is done.

Your Spektrum Transmitter comes prebound to the vehicle.

If you encounter problems, obey binding instructions and refer to the transmitter troubleshooting guide for other instructions. If needed, contact the appropriate Horizon Product Support office.

CONTROL TEST



Perform a control test with the vehicle wheels off the ground. If the wheels rotate after the vehicle is powered ON, adjust the "TH. Trim" knob until they stop. To make the wheels move forward, pull the trigger. To reverse them, wait for the wheels to stop, then push the trigger. When moving forward, the wheels should maintain a straight line without any steering wheel input. If not, adjust the "ST. Trim" knob so the wheels maintain a straight line without having to turn the steering wheel.

RUN TIME

BEFORE RUNNING YOUR VEHICLE

- 1 Check for free suspension movement. All suspension arms and steering components should move freely. Any binds will cause the vehicle to handle poorly.
- 2 Charge the battery.
- 3 Check the calibration of the ESC. If recalibration is required, follow the setup instructions.
- 4 Adjust the transmitter settings to your desired configuration.

The largest factor in run time is the capacity of the battery pack. A larger mAh rating increases the amount of run time experienced.

The condition of a battery pack is also an important factor in both run time and speed. The battery connectors may become hot during driving. Batteries will lose performance and capacity over time.

Driving the vehicle from a stop to full speed repeatedly will damage the batteries and electronics over time. Sudden acceleration will also lead to shorter run times.

TO IMPROVE RUN TIMES

- » Clean and oil bearings often. If bearings are dirty, they will increase friction and cause reduced performance.

- » Keep your vehicle clean and maintained.
- » Allow more airflow to the ESC and motor.
- » Change the gearing to a lower ratio. A lower ratio decreases the operating temperature of the electronics. Use a smaller pinion gear or larger spur gear to lower the gear ratio.
- » Use a battery pack with a higher mAh rating.
- » Do not drive the vehicle in tall grass. Doing so can damage the vehicle or electronics.
- » Stop driving the vehicle when you notice a lack of power. Driving the vehicle when the battery is overly discharged can cause the receiver to power off. If the receiver loses power, you will lose control of the vehicle.
- » Do not apply forward or reverse throttle if the vehicle is stuck. Applying throttle in this instance can damage the motor or ESC.
- » After driving the vehicle, allow the electronics to cool before driving the vehicle again. Remove the body of the vehicle to reduce cooling time.

DRIVING PRECAUTIONS

- » Maintain sight of the vehicle at all times.
- » Routinely inspect the vehicle for loose wheel hardware.
- » Routinely inspect the steering assembly for any loose hardware. Driving the vehicle off-road can cause fasteners to loosen over time.

TUNING, ADJUSTING & MAINTAINING YOUR VEHICLE

SERVICE/REPAIR

If any problems other than those covered in this manual arise, please call the appropriate electronics service department. Refer to the Warranty and Service Information section for the appropriate department to contact.

CLEANING

Performance can be hindered if dirt gets in any of the moving suspension parts. Use compressed air, a soft paintbrush, or a toothbrush to remove dust or dirt. Avoid using solvents or chemicals as they can actually wash dirt into the bearings or moving parts, as well as cause damage to the electronics.

- » Examine your vehicle on a regular basis.
- » Use a brush to remove dirt and dust.
- » Look for damage to the suspension arms and other molded parts.
- » Re-glue the tires to the wheels, if necessary.
- » Clean and oil all wheel bearings.
- » Use suitable tools to tighten fasteners.
- » Make sure the camber and steering linkages are not bent. Replace any bent linkages.
- » Adjust the Toe and Camber settings, if necessary.
- » Remove the shocks and inspect them for damage. Rebuild the shocks if oil is leaking.
- » Inspect electronics and batteries for exposed wires. Repair exposed wires with shrink-wrap, or replace the wire.
- » Make sure the ESC and receiver are secure on the chassis. Replace the double-sided tape, if necessary.
- » Power ON the transmitter. If the green LED is dim or off, replace the AA batteries in your transmitter.
- » Check the spur gear and pinion gear for wear.

ESC LED STATUS

- » No ESC LEDs will glow when there is no throttle input from the transmitter.
- » The red ESC LED glows when there is any throttle input from the transmitter.

AUDIBLE WARNING TONES

- 1 Input voltage:** The ESC checks the input voltage when it is powered ON. If a voltage problem is detected, the ESC continuously sounds 2 beeps with a 1 second pause (xx-xx-xx). Power OFF the ESC and ensure the connections are secure and that the battery power is not too low for safe operation.
- 2 Radio connection:** The ESC checks radio signal input when it is powered ON. If a problem is detected, the ESC continuously sounds 1 beep with a 2 second pause (x--x--x). Power OFF the ESC and ensure the radio system is operating correctly.

ESC CALIBRATION PROCEDURE

Ensure proper ESC function by calibrating the ESC to your transmitter inputs.

- 1** Power OFF the ESC.
- 2** Ensure your transmitter is powered ON, the throttle is not reversed, the throttle trim is neutral and the throttle travel range is at 100%.
- 3** Press the SET button while powering ON the ESC. Release the button as soon as the green LED starts to flash.
- 4** Calibrate the throttle points by pressing the SET button once after each step.
 - **Neutral (1 flash)** Leave the throttle at rest, untouched
 - **Full throttle (2 flashes)** Pull the throttle fully back
 - **Full brake/reverse (3 flashes)** Push the throttle fully forward
- 5** The motor vibrates for 3 seconds after the last step is completed.

ESC FUNCTIONS AND MODES

The ESC includes programming options so you can adjust the way your vehicle performs. Refer to the included settings table to adjust the ESC for your driving conditions.

ESC PROGRAMMING PROCEDURE

Programming is accomplished using the SET button on the ON/OFF switch.

Programming the ESC

- 1** Connect a fully charged battery to the ESC.
- 2** Power ON the ESC.
- 3** Hold the SET button for 1 second until the green LED blinks, then release the SET button to enter programming mode.
- 4** Press and release the SET button as needed to get to the desired menu option (the green LED will blink corresponding to the menu item number).
- 5** When at the desired menu item, hold the SET button for 3 seconds until the red LED blinks.
- 6** Press the SET button to move among the settings based on how many times the red LED blinks (Refer to the table for more information).
- 7** Save the setting by holding the SET button for 3 seconds.
- 8** Power OFF the ESC and repeat the instructions above to change other settings.

Tip: If desired, the ESC programming can be returned to default settings by powering ON the ESC and holding the SET button for 5 seconds.

TECHNICAL SPECIFICATIONS

- Type**
Sensorless Brushless/Waterproof
- Constant/Peak**
45A/290A
- Resistance**
0.0012 Ohms
- Function**
Forward Only with Brake
Forward/Reverse with Brake
- Operation**
Proportional forward, proportional reverse with braking delay
- Battery Type/ Input Voltage**
2-3 cell Li-Po/Li-Fe or
4-9 cell Ni-MH/Ni-Cd
- BEC Output**
6V/3A
- Overload Protection**
Thermal
- Dimensions (LxWxH)**
1.89 x 1.39 x 1.39 in
(48 x 35.2 x 35.2mm)
- Weight**
2.61 oz (74 g) with wires

NOTICE: Always disconnect the battery from the ESC when you have finished operating your vehicle. The ESC's switch only controls power to the receiver and servos. The ESC will continue to draw current when connected to the battery, resulting in possible damage to the battery through over-discharge.

Default Settings

PROGRAMMABLE ITEMS	PROGRAMMABLE VALUE							
	1	2	3	4	5	6	7	8
1 Running Mode	Forward Only with Brake	Forward/Reverse with Brake						
2 Drag Brake Force	0%	5%	10%	15%	20%	25%	30%	40%
3 Low Voltage Cutoff Threshold	non-protection	2.6V/Cell	2.8V/Cell	3.0V/Cell	3.2V/Cell	3.4V/Cell		
4 Start Mode (Punch)	Level 1	Level 2	Level 3	Level 4				
5 Max Brake Force	25%	50%	75%	100%				

DESCRIPTIONS

1 Running Mode

- **Forward Only with Brake**
Intended for competition use, this mode allows only forward and brake controls.
- **Forward/Reverse with Brake**
This mode is the basic all-around mode, allowing forward, reverse and brake controls. To engage reverse while moving forward, apply the brake until the vehicle has come to a complete stop. Release the brake, then apply the brake again. While braking or in reverse, engaging the throttle will result in the vehicle immediately accelerating forward.

2 Drag Brake Force

Adjusts the amount of brake automatically applied when the throttle is returned to neutral. This simulates the engine braking effect of a full-scale vehicle, allowing improved turn-in and your vehicle's general response to controls.

3 Low Voltage Cutoff Threshold

This function helps to prevent battery over-discharge. The ESC continuously monitors the battery's voltage. If the voltage falls below the voltage threshold for 2 seconds, the output power shuts off and the red LED flashes twice repeatedly.

The cutoff threshold calculation is based on individual Li-Po cell voltage. For Ni-MH batteries, if the voltage battery pack is higher than 9.0V, it will be treated as a 3-cell Li-Po battery pack; if it is lower than 9.0V, it will be treated as a 2-cell Li-Po battery pack.

Example: for a 8.0V Ni-MH battery pack used with a 2.6V/cell threshold, it will be treated as a 2-cell Li-Po battery pack and the low-voltage cutoff threshold will be 5.2V (2.6x2=5.2).

4 Start Mode (Punch)

Sets the initial throttle punch when the car accelerates. Level 1 gives a very soft initial acceleration and level 4 gives a stronger initial acceleration.

5 Max Brake Force

Adjusts the maximum braking force. A higher value provides stronger braking, but can also cause the wheels to lock, resulting in loss of control of the car.

DYNAMITE TAZER 3300KV 4-POLE BRUSHLESS MOTOR //////////////////////////////////////

RECOMMENDED BRUSHLESS MOTOR	MOTOR MOUNT PLATE POSITION	1st		FINAL (2.66)		TOTAL GEAR RATIO	MOTOR PLATE POSITION	
		Pinion	Spur	Drive	Ring			
Brushless motor 10.5 turn or less	A	22	77	12	32	9.33	STD 77T Spur Gear with minimum Pinion Gear ↓ STD 77T Spur Gear with max Pinion Gear	
	B	23	77	12	32	8.93		
	C	24	77	12	32	8.56		
	D	25	77	12	32	8.21		
	Brushless motor 3300Kv	E	26	77	12	32		7.90
		F	27	77	12	32		7.60
		G	28	77	12	32		7.33
		H	29	77	12	32		7.08
		I	30	77	12	32		6.84
		A	28	71	12	32	6.76	Optional 71T Spur Gear with minimum Pinion Gear ↓ Optional 71T Spur Gear with max Pinion Gear
		B	29	71	12	32	6.53	
		C	30	71	12	32	6.31	
		D	31	71	12	32	6.11	
		E	32	71	12	32	5.92	
	Brushless motor 13.5 turn	E	38	65	12	32	4.56	Optional 65T Spur Gear with minimum Pinion Gear ↓ Optional 65T Spur Gear with max Pinion Gear
F		39	65	12	32	4.44		
G		40	65	12	32	4.33		
H		41	65	12	32	4.23		
I		42	65	12	32	4.13		

PRECAUTIONS

- » Never touch moving parts.
- » Never disassemble while the batteries are installed.
- » Always let parts cool before touching.

COMES WITH STD KIT



PROBLEM	POSSIBLE CAUSE	SOLUTION
Vehicle does not operate	<ul style="list-style-type: none"> » Battery not charged or connected » ESC switch not ON » Transmitter not ON or low battery 	<ul style="list-style-type: none"> » Charge battery/connect » Turn ON ESC switch » Turn ON/replace batteries
Motor runs but rear wheels don't move	<ul style="list-style-type: none"> » Pinion not meshing with spur gear » Pinion spinning on motor shaft » Transmission gears stripped » Drive pin broken 	<ul style="list-style-type: none"> » Adjust pinion/spur mesh » Replace pinion gear on motor » Replace transmission gears » Check and replace drive pin
Steering does not work	<ul style="list-style-type: none"> » Servo plug not in receiver properly » Servo gears or motor damaged 	<ul style="list-style-type: none"> » Check if connected/all the way » Replace or repair servo
Won't turn in one direction	<ul style="list-style-type: none"> » Servo gears damaged 	<ul style="list-style-type: none"> » Replace servo
Motor does not run	<ul style="list-style-type: none"> » Motor plugs loose » Motor wire broken » ESC damaged 	<ul style="list-style-type: none"> » Plug in completely » Repair or replace as needed » Contact Horizon Hobby Product Support
ESC gets hot	<ul style="list-style-type: none"> » Motor over-gearred » Driveline bound up 	<ul style="list-style-type: none"> » Use smaller pinion or larger spur gear on motor » Check wheels, suspension and transmission for binding
Poor run time and/or sluggish acceleration	<ul style="list-style-type: none"> » Battery pack not fully charged » Charger not allowing full charge » Motor worn out » Driveline bound up 	<ul style="list-style-type: none"> » Recharge battery » Try another charger » Replace motor » Check wheels, transmission for binding
Poor range and/or glitching	<ul style="list-style-type: none"> » Transmitter batteries low » Vehicle battery low » Loose plugs or wires 	<ul style="list-style-type: none"> » Check and replace » Recharge or replace » Check all wire connections and plugs

LIMITED WARRANTY //////////////////////////////////////

WHAT THIS WARRANTY COVERS

Horizon Hobby, Inc., (Horizon) warrants to the original purchaser that the product purchased (the “Product”) will be free from defects in materials and workmanship at the date of purchase.

WHAT IS NOT COVERED

This warranty is not transferable and does not cover (i) cosmetic damage, (ii) damage due to acts of God, accident, misuse, abuse, negligence, commercial use, or due to improper use, installation, operation or maintenance, (iii) modification of or to any part of the Product, (iv) attempted service by anyone other than a Horizon Hobby authorized service center, (v) Product not purchased from an authorized Horizon dealer, or (vi) Product not compliant with applicable technical regulations.

OTHER THAN THE EXPRESS WARRANTY ABOVE, HORIZON MAKES NO OTHER WARRANTY OR REPRESENTATION, AND HEREBY DISCLAIMS ANY AND ALL IMPLIED WARRANTIES, INCLUDING, WITHOUT LIMITATION, THE IMPLIED WARRANTIES OF NON-INFRINGEMENT, MERCHANTABILITY AND FITNESS FOR A PARTICULAR PURPOSE. THE PURCHASER ACKNOWLEDGES THAT THEY ALONE HAVE DETERMINED THAT THE PRODUCT WILL SUITABLY MEET THE REQUIREMENTS OF THE PURCHASER’S INTENDED USE.

PURCHASER’S REMEDY

Horizon’s sole obligation and purchaser’s sole and exclusive remedy shall be that Horizon will, at its option, either (i) service, or (ii) replace, any Product determined by Horizon to be defective. Horizon reserves the right to inspect any and all Product(s) involved in a warranty claim. Service or replacement decisions are at the sole discretion of Horizon. Proof of purchase is required for all warranty claims. SERVICE OR REPLACEMENT AS PROVIDED UNDER THIS WARRANTY IS THE PURCHASER’S SOLE AND EXCLUSIVE REMEDY.

LIMITATION OF LIABILITY

HORIZON SHALL NOT BE LIABLE FOR SPECIAL, INDIRECT, INCIDENTAL OR CONSEQUENTIAL DAMAGES,

LOSS OF PROFITS OR PRODUCTION OR COMMERCIAL LOSS IN ANY WAY, REGARDLESS OF WHETHER SUCH CLAIM IS BASED IN CONTRACT, WARRANTY, TORT, NEGLIGENCE, STRICT LIABILITY OR ANY OTHER THEORY OF LIABILITY, EVEN IF HORIZON HAS BEEN ADVISED OF THE POSSIBILITY OF SUCH DAMAGES. Further, in no event shall the liability of Horizon exceed the individual price of the Product on which liability is asserted. As Horizon has no control over use, setup, final assembly, modification or misuse, no liability shall be assumed nor accepted for any resulting damage or injury. By the act of use, setup or assembly, the user accepts all resulting liability. If you as the purchaser or user are not prepared to accept the liability associated with the use of the Product, purchaser is advised to return the Product immediately in new and unused condition to the place of purchase.

LAW

These terms are governed by Illinois law (without regard to conflict of law principals). This warranty gives you specific legal rights, and you may also have other rights which vary from state to state. Horizon reserves the right to change or modify this warranty at any time without notice.

WARRANTY SERVICES

QUESTIONS, ASSISTANCE, AND SERVICES

Your local hobby store and/or place of purchase cannot provide warranty support or service. Once assembly, setup or use of the Product has been started, you must contact your local distributor or Horizon directly. This will enable Horizon to better answer your questions and service you in the event that you may need any assistance. For questions or assistance, please visit our website at www.horizonhobby.com, submit a Product Support Inquiry, or call the toll free telephone number referenced in the Warranty and Service Contact Information section to speak with a Product Support representative.

INSPECTION OR SERVICES

If this Product needs to be inspected or serviced and is compliant in the country you live and use the Product in, please use the Horizon Online Service Request submission process found on our website or call Horizon to obtain a Return Merchandise Authorization (RMA) number. Pack the Product securely using a shipping carton. Please note that original boxes may be included, but are not designed to withstand the rigors of shipping without additional protection. Ship via a carrier that provides tracking and insurance for lost or damaged parcels, as Horizon is not responsible for merchandise until it arrives and is accepted at our facility. An Online Service Request is available at http://www.horizonhobby.com/content/_service-center_render-service-center. If you do not have internet access, please contact Horizon Product Support to obtain a RMA number along with instructions for submitting your product for service. When calling Horizon, you will be asked to provide your complete name, street address, email address and phone number where you can be reached during business hours. When sending product into Horizon, please include your RMA number, a list of the included items, and a brief summary of the problem. A copy of your original sales receipt must be included for warranty consideration. Be sure your name, address, and RMA number are clearly written on the outside of the shipping carton.

NOTICE: Do not ship Li-Po batteries to Horizon. If you have any issue with a LiPo battery, please contact the appropriate Horizon Product Support office.

WARRANTY REQUIREMENTS

For Warranty consideration, you must include your original sales receipt verifying the proof-of-purchase date. Provided warranty conditions have been met, your Product will be serviced or replaced free of charge. Service or replacement decisions are at the sole discretion of Horizon.

NON-WARRANTY SERVICE

Should your service not be covered by warranty, service will be completed and payment will be required without notification or estimate of the expense unless the expense exceeds 50% of the retail purchase cost.

By submitting the item for service you are agreeing to payment of the service without notification. Service estimates are available upon request. You must include this request with your item submitted for service. Non-warranty service estimates will be billed a minimum of 1/2 hour of labor. In addition you will be billed for return freight. Horizon accepts money orders and cashier's checks, as well as Visa, MasterCard, American Express, and Discover cards. By submitting any item to Horizon for service, you are agreeing to Horizon's Terms and Conditions found on our website http://www.horizon-hobby.com/content/_service-center_render-service-center.

ATTENTION: Horizon service is limited to Product compliant in the country of use and ownership. If received, a non-compliant Product will not be serviced. Further, the sender will be responsible for arranging return shipment of the un-serviced Product, through a carrier of the sender's choice and at the sender's expense. Horizon will hold non-compliant Product for a period of 60 days from notification, after which it will be discarded.

WARRANTY AND SERVICE CONTACT INFORMATION

COUNTRY OF PURCHASE	HORIZON HOBBY	CONTACT INFORMATION	ADDRESS
United States of America	Horizon Service Center (Repairs and Repair Requests)	servicecenter.horizonhobby.com/RequestForm/	4105 Fieldstone Rd Champaign, Illinois 61822 USA
	Horizon Product Support (Product Technical Assistance)	www.quickbase.com/db/bghj7ey8c?a=GenNewRecord 888-959-2306	
	Sales	sales@horizonhobby.com 888-959-2306	
United Kingdom	Service/Parts/Sales: Horizon Hobby Limited	sales@horizonhobby.co.uk +44 (0) 1279 641 097	Units 1-4 Ployters Rd Staple Tye Harlow, Essex CM18 7NS United Kingdom
Germany	Horizon Technischer Service	service@horizonhobby.de +49 (0) 4121 2655 100	Christian-Junge-Straße 1 25337 Elmshorn
	Sales: Horizon Hobby GmbH		
France	Horizon Hobby SAS	infofrance@horizonhobby.com +33 (0) 1 60 18 34 90	11 Rue Georges Charpak 77127 Lieusaint, France
China	Service/Parts/Sales: Horizon Hobby - China	info@horizonhobby.com.cn +86 (021) 5180 9868	Room 506 No. 97 Changshou Rd. Shanghai, China 200060

FCC INFORMATION //////////////////////////////////////

This device complies with part 15 of the FCC rules. Operation is subject to the following two conditions: (1) This device may not cause harmful interference, and (2) this device must accept any interference received, including interference that may cause undesired operation.

CAUTION: Changes or modifications not expressly approved by the party responsible for compliance could void the user's authority to operate the equipment.

This product contains a radio transmitter with wireless technology which has been tested and found to be compliant with the applicable regulations governing a radio transmitter in the 2.400GHz to 2.4835GHz frequency range.

ANTENNA SEPARATION DISTANCE

When operating your Spektrum transmitter, please be sure to maintain a separation distance of at least 5 cm between your body (excluding fingers, hands, wrists, ankles and feet) and the antenna to meet RF exposure safety requirements as determined by FCC regulations.

The following illustrations show the approximate 5 cm RF exposure area and typical hand placement when operating your Spektrum transmitter.

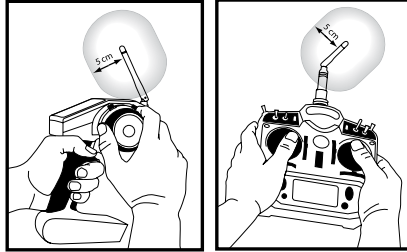

IC INFORMATION //////////////////////////////////////

This device complies with Industry Canada licence-exempt RSS standard(s). Operation is subject to the following two conditions: (1) this device may not cause interference, and (2) this device must accept any interference, including interference that may cause undesired operation of the device.

COMPLIANCE INFORMATION FOR THE EUROPEAN UNION //////////////////////////////////////

AT	BE	BG	CZ	CY	DE	DK
ES	FI	FR	GR	HU	IE	IT
LT	LU	LV	MT	NL	PL	PT
RO	SE	SI	SK	UK		

CE DECLARATION OF CONFORMITY (in accordance with ISO/IEC 17050-1)

No. HH2013052203

Product(s): 69 Chevrolet Camaro SS Brushless V100-S 1/10 RTR (Spektrum DX2E transmitter and SR200WP receiver included)

Item Number(s): VTR030161

Equipment class: 2

The object of declaration described above is in conformity with the requirements of the specifications listed below, following the provisions of the European R&TTE directive 1999/5/EC, EMC Directive 2004/108/EC and LVD Directive 2006/95/EC:

EN 300-328 V1.7.1: 2006

EN301 489-1 V1.9.2: 2012

EN301 489-17 V2.1.1: 2009

EN60950-1:2006+A11:2009+A1:2010+A12: 2011

EN55022:2010 + AC:2011

EN55024:2010

EN61000-3-2:2006+A1:2009+A2:2009

EN61000-3-3:2008

Signed for and on behalf of:

Horizon Hobby, Inc.

Steven A. Hall

Champaign, IL USA

Executive Vice President and Chief Operating Officer

May 22, 2013

International Operations and Risk Management

Horizon Hobby, Inc.



INSTRUCTIONS FOR DISPOSAL OF WEEE BY USERS IN THE EUROPEAN UNION

This product must not be disposed of with other waste. Instead, it is the user's responsibility to dispose of their waste equipment by handing it over to a designated collection point for the recycling of waste electrical and electronic equipment. The separate collection and recycling of your waste equipment at the time of disposal will help to conserve natural resources and ensure that it is recycled in a manner that protects human health and the environment. For more information about where you can drop off your waste equipment for recycling, please contact your local city office, your household waste disposal service or where you purchased the product.