

Name: 8IGHT-E 4.0 Standard Setup	Date: _____
City: _____	Event: _____
State: _____	Track: _____

Track Indoor Tight Smooth Hard Packed Blue Groove Wet Low Bite High Bite
 Conditions Outdoor Open Rough Loose/Loamy Dry Dusty Med Bite Other _____

Front Suspension

Toe: 1° Toe Out _____
 Ride Height: 29mm _____
 Camber: -2° _____
 Caster: 27° _____
 Spindle Height: High Low
 Wheel Hex: Standard Hex _____
 Sway Bar: 2.3mm _____
 Piston/Oil: 8 Hole 1.3mm/40 wt _____
 Shock Type: Bladder Emulsion
 Spring: Green 4.8 lbs. _____
 Limiter/Droop: 103.5mm _____
 Overall Shock Length: _____
 Steering Ackerman: Long _____
 Bump Steer: Up _____
 Camber Link: 2 _____
 Shock Location: 3/Outside _____
 Battery Location: Forward Aft

Differentials

Front: Standard Smart
 Spring Wire Dia. _____
 Qty of Springs: _____
 Ramp Plate: _____
 Grease: _____
 Diff Fluid: 5000 wt _____

Center: Standard Smart
 Location: 0-Degree 4.4-Degree
 Spring Wire Dia.: _____
 Qty of Springs: _____
 Ramp Plate: _____
 Grease: _____
 Diff Fluid: 7000 wt _____

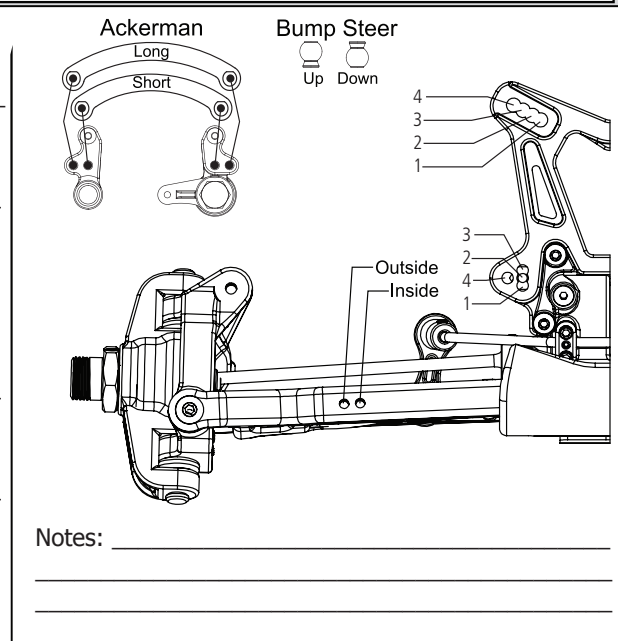

Rear Suspension

Roll Center: HRC LRC
 Toe: 3° _____
 Anti-Squat: 3° _____
 Ride Height: 29mm _____
 Camber: -2° _____
 Rear Hub Spacing: Back _____
 Wheel Hex: +1mm Hex _____
 Sway Bar: 2.3mm _____
 Piston/Oil: 8 Hole Split 1.2mm & 1.3mm/25wt _____
 Shock Type: Bladder Emulsion
 Spring: Silver 3.6 lbs _____
 Limiter/Droop: 114mm _____
 Overall Shock Length: _____
 Camber Link: 2/B _____
 Shock Position: 3/Outside _____
 Rear Diff Fluid: 3000 wt _____

Wing Setup

Wing Type: 2.0 3.0
 Wing Spacer: .250 .500
 Wicker Bill: .250 .350

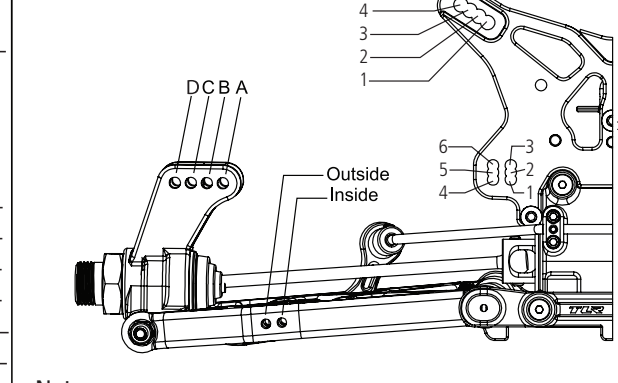

Electronics

Radio: _____
 Servo: _____
 ESC: _____
 Initial Brake: _____
 Drag Brake: _____
 Throttle Profile: _____
 Timing Advance: _____
 Throttle/Brake Expo: _____
 Throttle/Brake EPA: _____
 Servo Expo: _____
 Motor: _____
 Pinion: _____
 Spur: 45T _____
 Battery: _____

Clutch Clutch Shoes and Springs Info

Tires

Type	Compound	Insert
Front: _____	_____	_____
Rear: _____	_____	_____

Notes: _____

