

Name: BIGHT-T 3.0 Standard Setup Date: \_\_\_\_\_ Event: \_\_\_\_\_  
 City: \_\_\_\_\_ State: \_\_\_\_\_ Track: \_\_\_\_\_  
 Track Conditions:  Indoor  Tight  Smooth  Hard Packed  Blue Groove  Wet  Low Bite  High Bite  
 Outdoor  Open  Rough  Loose/Loamy  Dry  Dusty  Med Bite  Other \_\_\_\_\_

**Front Suspension**  
 Toe: 1° Toe Out  
 Ride Height: 38mm  
 Camber: -1°  
 Caster: 15°  
 Wheel Hex: Standard Hex  
 Sway Bar: 2.3mm  
 Piston/Oil: 5 Hole 1.4mm/35 wt  
 Spring: Grey 6.0 lbs.  
 Limiter/Droop: 114.5mm  
 Steering Ackerman: Long  
 Bump Steer: Up  
 Camber Link: 2  
 Shock Location: 2/Inside  
 Receiver Battery Type: \_\_\_\_\_

**Differentials**  
 Front:  Standard  Smart  
 Spring Wire Dia: \_\_\_\_\_  
 Qty of Springs: \_\_\_\_\_  
 Ramp Plate: \_\_\_\_\_  
 Grease: \_\_\_\_\_  
 Diff Fluid: 7000 wt  
 Center:  Standard  Smart  
 Spring Wire Dia: \_\_\_\_\_  
 Qty of Springs: \_\_\_\_\_  
 Ramp Plate: \_\_\_\_\_  
 Grease: \_\_\_\_\_  
 Diff Fluid: 10000 wt

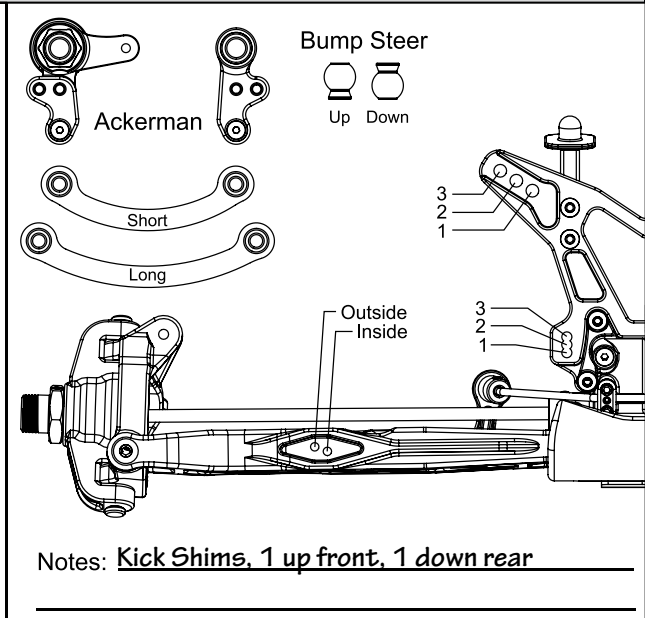

**Rear Suspension**  
 Roll Center:  HRC  LRC  HRC Fwd/LRC Rear  
 Toe: 3°  
 Anti-Squat: 4°  
 Ride Height: 40mm  
 Camber: -2  
 Rear Hub Spacing: Back  
 Wheel Hex: Standard Hex  
 Sway Bar: 2.3mm  
 Piston/Oil: 5 Hole 1.5mm/40 wt  
 Spring: Grey 5.8 lbs  
 Limiter/Droop: 129mm  
 Camber Link: 3/C  
 Shock Location: 2/Middle  
 Rear Diff Fluid: 7000 wt

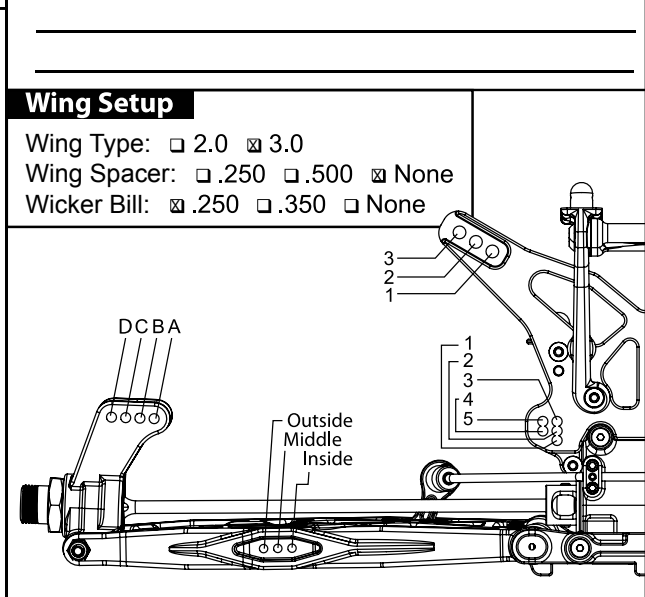

**Engine**  
 Engine: \_\_\_\_\_ Fuel: \_\_\_\_\_  
 Glow Plug: \_\_\_\_\_ Head Clearance: \_\_\_\_\_  
 Pipe/Header: \_\_\_\_\_ Gearing: 12/50

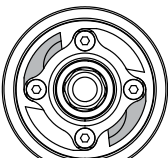
**Clutch** Clutch Shoes and Springs Info  
  
2 carbon with green springs  
and 2 aluminum with gold springs.  
Alum Flywheel

**Tires**

	Type	Compound	Insert
Front:	_____	_____	_____
Rear:	_____	_____	_____
Notes:	_____		