

Name: _____ Date: _____ Event: _____
 City: _____ State: _____ Track: _____

Track Indoor Tight Smooth Hard Packed Blue Groove Wet Low Bite High Bite
 Conditions Outdoor Open Rough Loose/Loamy Dry Dusty Med Bite Other _____

Front Suspension

Toe: _____
 Ride Height: _____
 Camber: _____
 Caster: _____
 Wheel Hex: _____
 Sway Bar: _____
 Piston/Oil: _____
 Spring: _____
 Limiter/Droop: _____
 Steering Ackerman: _____
 Bump Steer: _____
 Camber Link: _____
 Shock Location: _____
 Receiver Battery Type: _____

Differentials

Front: Standard Smart
 Spring Wire Dia: _____
 Qty of Springs: _____
 Ramp Plate: _____
 Grease: _____
 Diff Fluid: _____

Center: Standard Smart
 Spring Wire Dia: _____
 Qty of Springs: _____
 Ramp Plate: _____
 Grease: _____
 Diff Fluid: _____

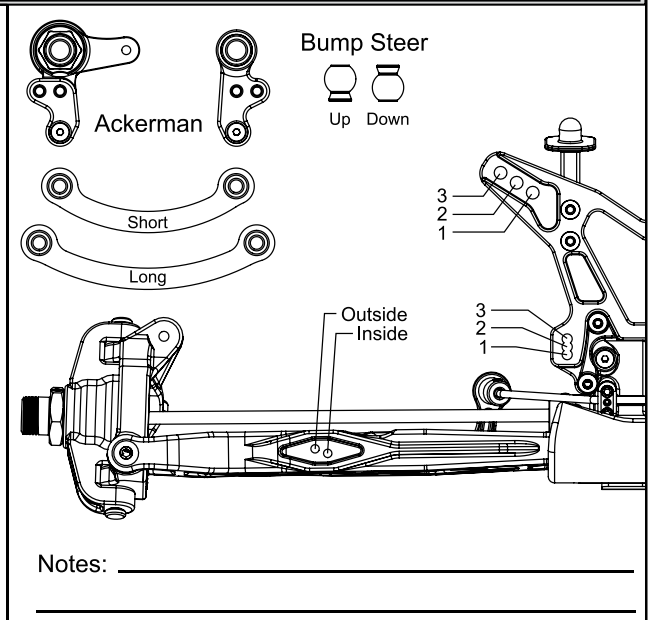

Rear Suspension

Roll Center: HRC LRC HRC Fwd/LRC Rear
 Toe: _____
 Anti-Squat: _____
 Ride Height: _____
 Camber: _____
 Rear Hub Spacing: _____
 Wheel Hex: _____
 Sway Bar: _____
 Piston/Oil: _____
 Spring: _____
 Limiter/Droop: _____
 Camber Link: _____
 Shock Location: _____
 Rear Diff Fluid: _____

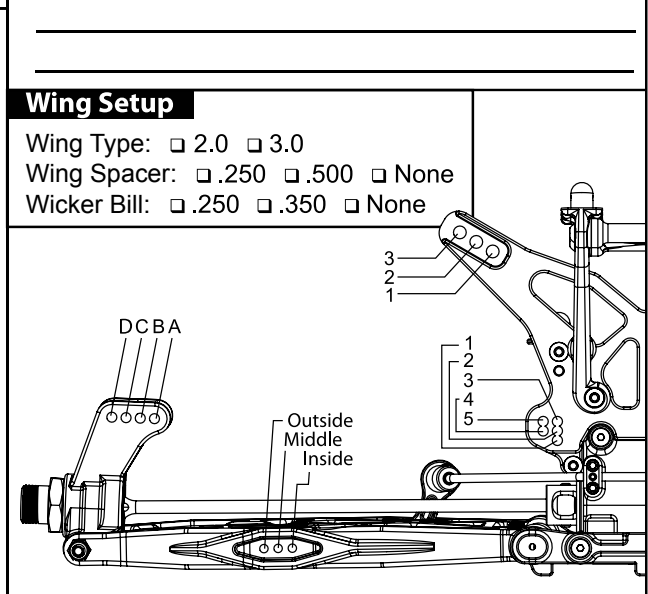

Engine

Engine: _____ Fuel: _____
 Glow Plug: _____ Head Clearance: _____
 Pipe/Header: _____ Gearing: _____

Clutch Clutch Shoes and Springs Info

Tires

	Type	Compound	Insert
Front:	_____	_____	_____
Rear:	_____	_____	_____
Notes:	_____		