

Name: \_\_\_\_\_ Date: \_\_\_\_\_ Event: \_\_\_\_\_  
 City: \_\_\_\_\_ State: \_\_\_\_\_ Track: \_\_\_\_\_

Track  Indoor  Tight  Smooth  Hard Packed  Blue Groove  Wet  Low Bite  High Bite  
 Conditions  Outdoor  Open  Rough  Loose/Loamy  Dry  Dusty  Med Bite  Other \_\_\_\_\_

**Front Suspension**

Toe: \_\_\_\_\_  
 Ride Height: \_\_\_\_\_  
 Camber: \_\_\_\_\_  
 Caster: \_\_\_\_\_  
 Wheel Hex: \_\_\_\_\_  
 Sway Bar: \_\_\_\_\_  
 Piston/Oil: \_\_\_\_\_  
 Spring: \_\_\_\_\_  
 Limiter/Droop: \_\_\_\_\_  
 Steering Ackerman: \_\_\_\_\_  
 Bump Steer: \_\_\_\_\_  
 Camber Link: \_\_\_\_\_  
 Shock Location: \_\_\_\_\_  
 Receiver Battery Type: \_\_\_\_\_

**Differentials**

Front:  Standard  Smart  
 Spring Wire Dia: \_\_\_\_\_  
 Qty of Springs: \_\_\_\_\_  
 Ramp Plate: \_\_\_\_\_  
 Grease: \_\_\_\_\_  
 Diff Fluid: \_\_\_\_\_

Center:  Standard  Smart  
 Spring Wire Dia: \_\_\_\_\_  
 Qty of Springs: \_\_\_\_\_  
 Ramp Plate: \_\_\_\_\_  
 Grease: \_\_\_\_\_  
 Diff Fluid: \_\_\_\_\_

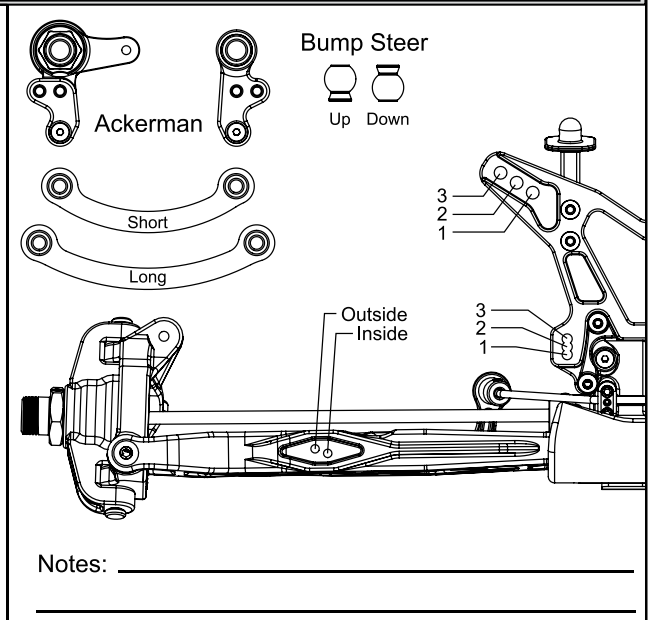

**Rear Suspension**

Roll Center:  HRC  LRC  HRC Fwd/LRC Rear  
 Toe: \_\_\_\_\_  
 Anti-Squat: \_\_\_\_\_  
 Ride Height: \_\_\_\_\_  
 Camber: \_\_\_\_\_  
 Rear Hub Spacing: \_\_\_\_\_  
 Wheel Hex: \_\_\_\_\_  
 Sway Bar: \_\_\_\_\_  
 Piston/Oil: \_\_\_\_\_  
 Spring: \_\_\_\_\_  
 Limiter/Droop: \_\_\_\_\_  
 Camber Link: \_\_\_\_\_  
 Shock Location: \_\_\_\_\_  
 Rear Diff Fluid: \_\_\_\_\_

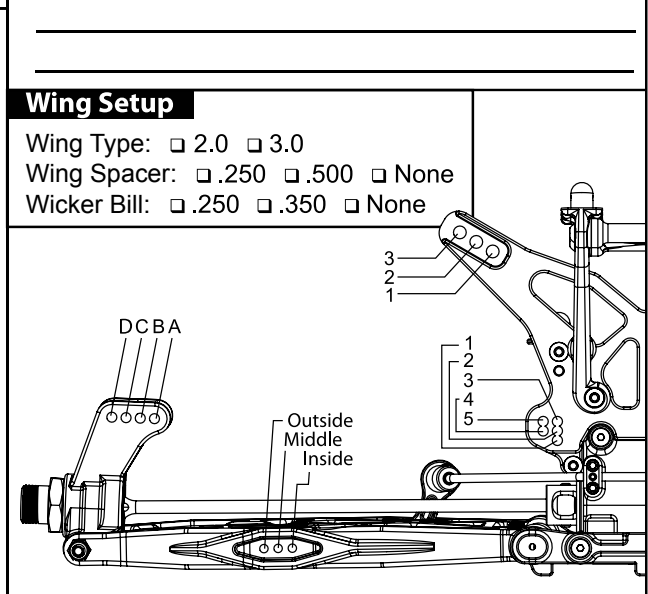

**Engine**

Engine: \_\_\_\_\_ Fuel: \_\_\_\_\_  
 Glow Plug: \_\_\_\_\_ Head Clearance: \_\_\_\_\_  
 Pipe/Header: \_\_\_\_\_ Gearing: \_\_\_\_\_

**Clutch** Clutch Shoes and Springs Info

\_\_\_\_\_

\_\_\_\_\_

\_\_\_\_\_

**Tires**

	Type	Compound	Insert
Front:	_____	_____	_____
Rear:	_____	_____	_____
Notes:	_____		