

Name: \_\_\_\_\_ Date: \_\_\_\_\_ Event: \_\_\_\_\_ Track: \_\_\_\_\_

**Track Conditions**

Indoor  Clay  Carpet  Tight  Smooth  Hard Packed  Blue Groove  Wet  Bite:  Low  Med  High  Other: \_\_\_\_\_

Outdoor  Dirt  Astro  Open  Rough  Loose/Loamy  Dry  Dusty  Tread:  Pin  Ghost  Slicks \_\_\_\_\_

**Front Suspension**

Ride Height \_\_\_\_\_ mm

Camber \_\_\_\_\_ °

Toe \_\_\_\_\_ °

Sway Bar \_\_\_\_\_ mm

Notes: \_\_\_\_\_

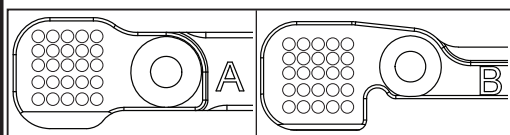
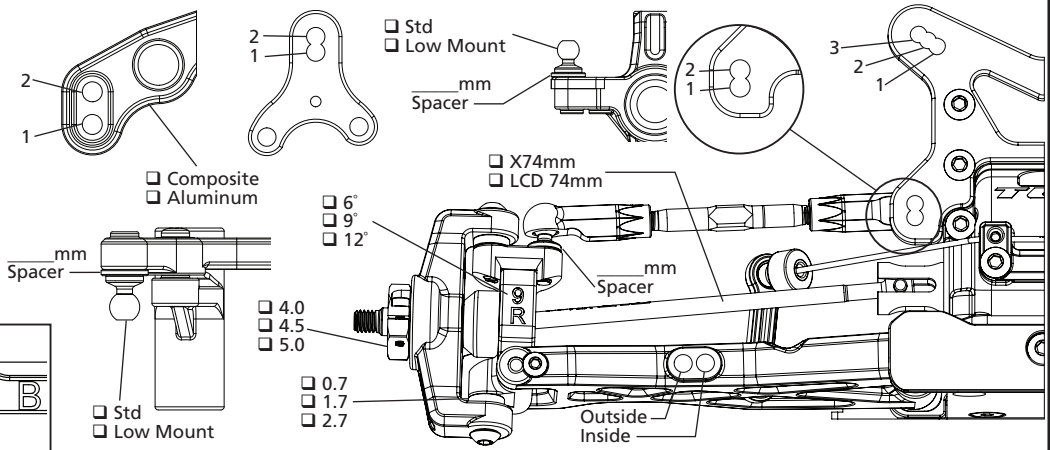

**Rear Suspension**

Ride Height \_\_\_\_\_ mm

Camber \_\_\_\_\_ °

Sway Bar \_\_\_\_\_ mm

Notes: \_\_\_\_\_

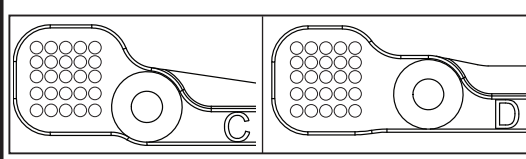
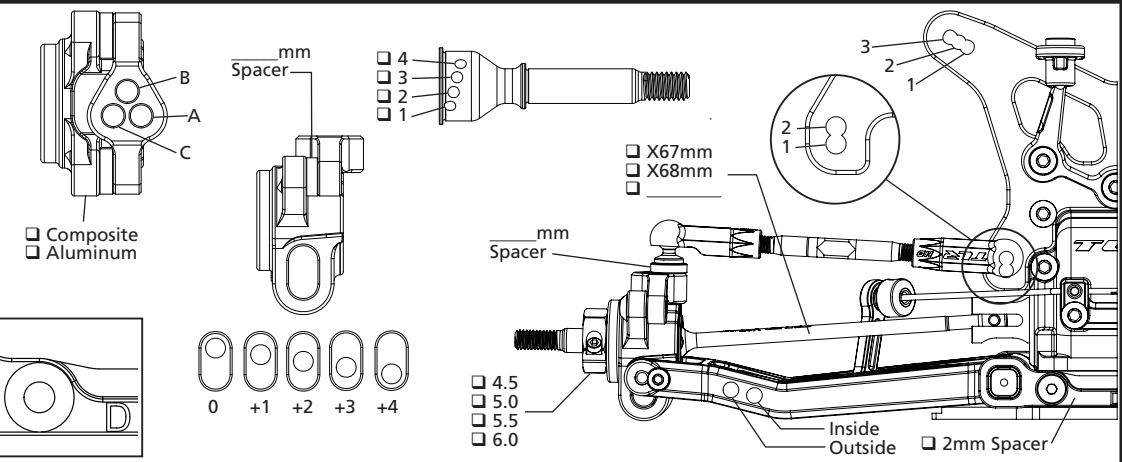

**Chassis**

Differentials	Front	Center	Rear
Fluid			
Int Gears	<input type="checkbox"/> Stl <input type="checkbox"/> Comp	<input type="checkbox"/> Stl <input type="checkbox"/> Comp	<input type="checkbox"/> Stl <input type="checkbox"/> Comp
Weight	_____ g	_____ g	_____ g
Ring/Pin	<input type="checkbox"/> Stl <input type="checkbox"/> Comp	<input type="checkbox"/> Stl <input type="checkbox"/> Comp	<input type="checkbox"/> Stl <input type="checkbox"/> Comp
Center Diff Cover	<input type="checkbox"/> Composite <input type="checkbox"/> Aluminum		
Slipper Pads	<input type="checkbox"/> Torque/Yellow <input type="checkbox"/> Drive/Orange		

Aerodynamics
Body
Fr Scoop
Rr Wing
Wicker
Angle
Notes

Tires	Front	Rear
Brand		
Tread		
Compound		
Insert		
Sauce		
Wheel		
Notes		

**Shocks**

	Front	Rear
Shock Caps		
Oil		
Piston	<input type="checkbox"/> Thin	<input type="checkbox"/> Thin
Limiter, Int	_____ mm	_____ mm
Shaft Dia	<input type="checkbox"/> 3.0mm <input type="checkbox"/> 3.5mm	<input type="checkbox"/> 3.0mm <input type="checkbox"/> 3.5mm
Limiter, Ext	_____ mm	_____ mm
Stroke	_____ mm	_____ mm
Eyelet	<input type="checkbox"/> Std <input type="checkbox"/> +2mm	<input type="checkbox"/> Std <input type="checkbox"/> +2mm
Spring		
Spring Cup	<input type="checkbox"/> Low <input type="checkbox"/> Mid <input type="checkbox"/> High	<input type="checkbox"/> Low <input type="checkbox"/> Mid <input type="checkbox"/> High

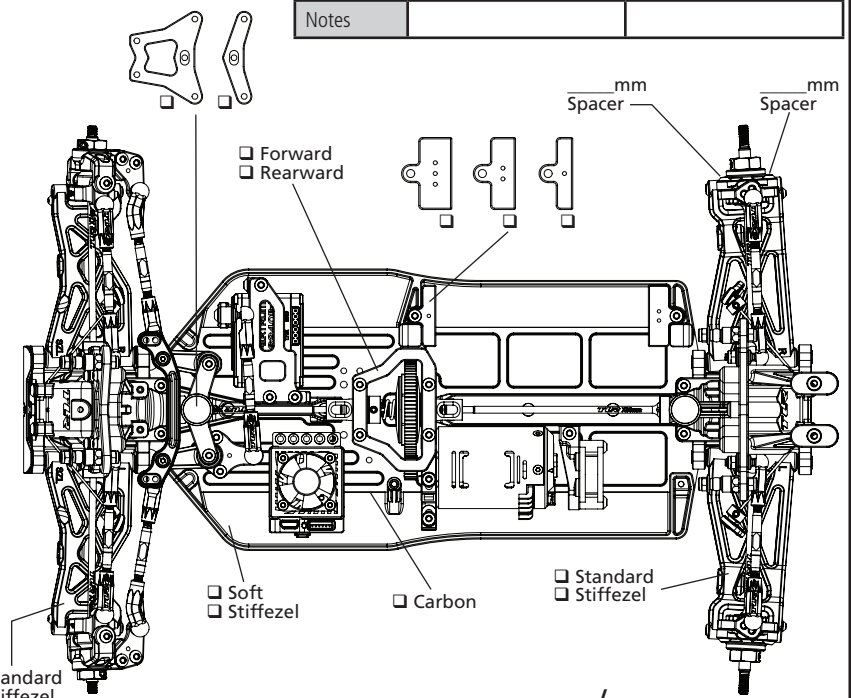

**Electronics**

Radio		ESC	
Servo		Thro Prof	
Battery		Timing Adv	
Battery Wt	_____ g	Initial Brake	
Motor		Drag Brake	
Gearing	/	Thr/Bra EPA	/

Total Weight: \_\_\_\_\_ g Fr/Rr \_\_\_\_\_ % / \_\_\_\_\_ %