

Name: <u>Kit Setup</u>		Date: _____	Event: _____
City: _____ State: _____		Track: _____	
Track Conditions	<input type="checkbox"/> Indoor <input type="checkbox"/> Tight <input type="checkbox"/> Smooth <input type="checkbox"/> Hard Packed <input type="checkbox"/> Blue Groove <input type="checkbox"/> Wet <input type="checkbox"/> Grass <input type="checkbox"/> Low Bite <input type="checkbox"/> High Bite	<input type="checkbox"/> Outdoor <input type="checkbox"/> Open <input type="checkbox"/> Rough <input type="checkbox"/> Loose/Loamy <input type="checkbox"/> Dry <input type="checkbox"/> Dusty <input type="checkbox"/> Astro Turf <input type="checkbox"/> Med Bite <input type="checkbox"/> Other _____	

**Front Suspension**

Toe: +/- 0 degrees

Ride Height: 24mm

Camber: -1mm

Caster:  0°  5° Trail:  2mm  4mm

Kick Angle:  20°  25°  30°

Sway Bar: None

Oil: 30 wt.

Piston: 2 x 1.6mm (TLR233009)

Spring:  Standard  Low Freq. Color: Red

Front Pivot:  Aluminum  Plastic  HRC

Kick Shim:  Brass  Plastic

Shock Limiters: 3mm

Shock Location: 2 - Outside

Bump Steer Ball Stud:  Standard  Low Mount

Bumper Steer Spacers: 1mm

Ackermann Ball Stud:  Standard  Low Mount

Ackermann Spacers: 0 washers

Camber Link: 2 - B

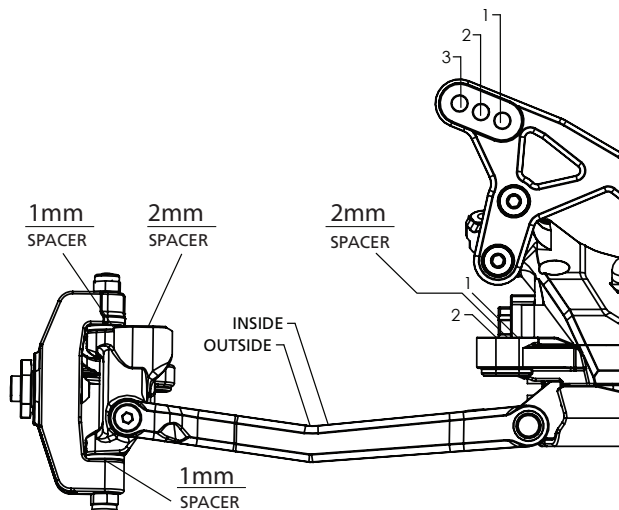

Notes: \_\_\_\_\_

\_\_\_\_\_

\_\_\_\_\_

**Rear Suspension**

Chassis Configuration:  Rear Motor  Mid Motor

Toe: 3 Degrees

Anti-Squat: 2 Degrees

Roll Center:  Low Roll Center (LRC)  High Roll Center (HRC)

Ride Height: 24mm

Camber: -1 Degree

Rear Hub Spacing: 2mm Front, 2mm Rear

Hex Width: Standard

Sway Bar: None

Oil: 30 wt.

Piston: 2 x 1.6mm (TLR233009)

Spring:  Standard  Low Freq. Color: Yellow

Shock Limiters: None

Camber Link: 1-D

Shock Locations: 2 - Inside

Wing/Wickerbill: \_\_\_\_\_

Battery Position: \_\_\_\_\_

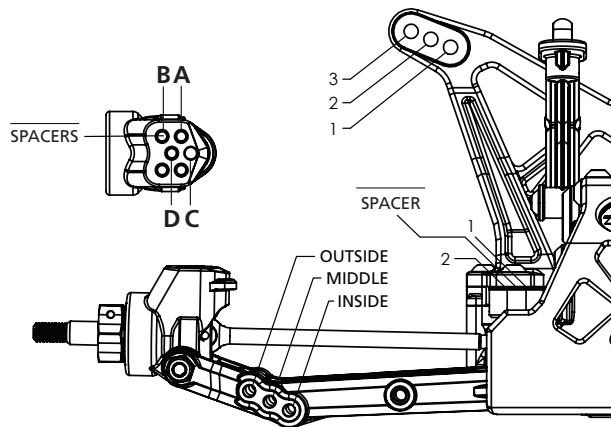

**Electronics**

Radio: \_\_\_\_\_ Timing Advance: \_\_\_\_\_

Servo: \_\_\_\_\_ Throttle/Brake Expo: \_\_\_\_\_

ESC: \_\_\_\_\_ Servo Expo: \_\_\_\_\_

Initial Brake: \_\_\_\_\_ Throttle/Brake EPA: \_\_\_\_\_

Drag Brake: \_\_\_\_\_ Motor: \_\_\_\_\_

Throttle Profile: \_\_\_\_\_ Pinion: \_\_\_\_\_ Spur: \_\_\_\_\_

Battery: \_\_\_\_\_

<p>Weight Placement (Mark with "X")</p> <p>Weight of each piece _____ oz./g</p>	Tires	Compound	Insert	Additive
	Front: _____	_____	_____	_____
	Rear: _____	_____	_____	_____
Notes: _____				