

Name: _____	Date: _____ Event: _____
City: _____ State: _____	Track: _____

Track Conditions:  Indoor  Outdoor  Tight  Open  Smooth  Rough  Hard Packed  Loose/Loamy  Blue Groove  Dry  Wet  Dusty  Grass  Astro Turf  Low Bite  Med Bite  High Bite  Other \_\_\_\_\_

**Front Suspension**

Toe: \_\_\_\_\_  
 Ride Height: \_\_\_\_\_  
 Camber: \_\_\_\_\_  
 Caster:  0°  5° Trail:  2mm  4mm  
 Kick Angle:  20°  25°  30°  
 Sway Bar: \_\_\_\_\_  
 Oil: \_\_\_\_\_  
 Piston: \_\_\_\_\_  
 Spring:  Standard  Low Freq. Color: \_\_\_\_\_  
 Front Pivot:  Aluminum  Plastic  HRC  
 Kick Shim:  Brass  Plastic  
 Shock Limiters: \_\_\_\_\_  
 Shock Location: \_\_\_\_\_  
 Bump Steer Ball Stud:  Standard  Low Mount  
 Bumper Steer Spacers: \_\_\_\_\_  
 Ackermann Ball Stud:  Standard  Low Mount  
 Ackermann Spacers: \_\_\_\_\_  
 Camber Link: \_\_\_\_\_

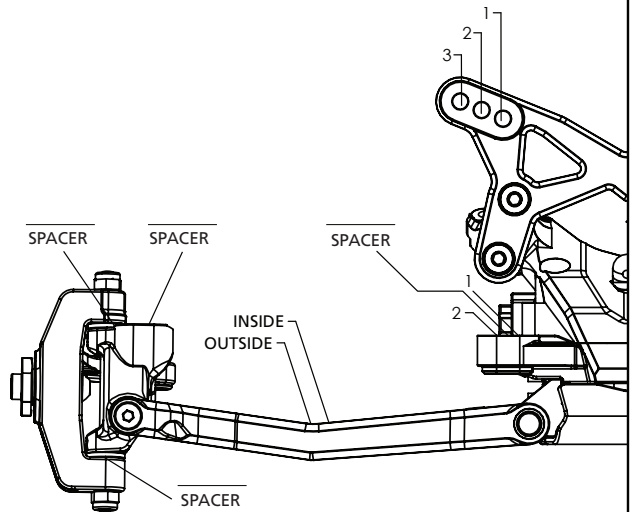

Notes: \_\_\_\_\_  
 \_\_\_\_\_  
 \_\_\_\_\_

**Rear Suspension**

Chassis Configuration:  Rear Motor  Mid Motor  
 Toe: \_\_\_\_\_  
 Anti-Squat: \_\_\_\_\_  
 Roll Center:  Low Roll Center (LRC)  High Roll Center (HRC)  
 Ride Height: \_\_\_\_\_  
 Camber: \_\_\_\_\_  
 Rear Hub Spacing: \_\_\_\_\_  
 Hex Width: \_\_\_\_\_  
 Sway Bar: \_\_\_\_\_  
 Oil: \_\_\_\_\_  
 Piston: \_\_\_\_\_  
 Spring:  Standard  Low Freq. Color: \_\_\_\_\_  
 Shock Limiters: \_\_\_\_\_  
 Camber Link: \_\_\_\_\_  
 Shock Locations: \_\_\_\_\_  
 Wing/Wickerbill: \_\_\_\_\_  
 Battery Position: \_\_\_\_\_

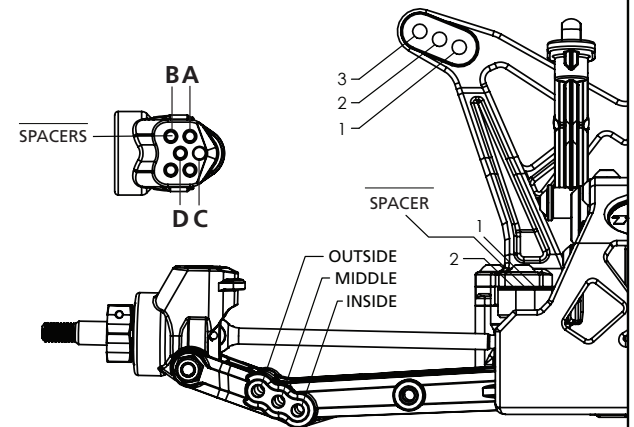

**Electronics**

Radio: _____	Timing Advance: _____
Servo: _____	Throttle/Brake Expo: _____
ESC: _____	Servo Expo: _____
Initial Brake: _____	Throttle/Brake EPA: _____
Drag Brake: _____	Motor: _____
Throttle Profile: _____	Pinion: _____ Spur: _____
	Battery: _____

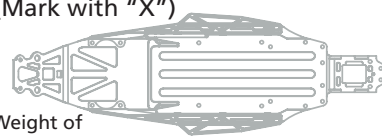
Weight Placement (Mark with "X")  Weight of each piece _____ oz./g	Tires	Compound	Insert	Additive
	Front: _____	_____	_____	_____
	Rear: _____	_____	_____	_____
Notes: _____				