

SPEKTRUM®

**SPMLTT1000, SPMLTT2500, SPMLTG5000
SPEKTRUM LAP TIMING SYSTEM**

SPEKTRUM RUNDEN-TIMER

**SYSTÈME DE CHRONOMÉTRAGE DE TOURS
SPEKTRUM**

SISTEMA DI CRONOMETRAGGIO SPEKTRUM

NOTICE

All instructions, warranties and other collateral documents are subject to change at the sole discretion of Horizon Hobby, LLC. For up-to-date product literature, visit horizonhobby.com and click on the support tab for this product.

Meaning of Special Language

The following terms are used throughout the product literature to indicate various levels of potential harm when operating this product:

WARNING: Procedures, which if not properly followed, create the probability of property damage, collateral damage, and serious injury OR create a high probability of superficial injury.

CAUTION: Procedures, which if not properly followed, create the probability of physical property damage AND a possibility of serious injury.

NOTICE: Procedures, which if not properly followed, create a possibility of physical property damage AND a little or no possibility of injury.



WARNING: Read the ENTIRE instruction manual to become familiar with the features of the product before operating. Failure to operate the product correctly can result in damage to the product, personal property and cause serious injury.

This is a sophisticated hobby product. It must be operated with caution and common sense and requires some basic mechanical ability. Failure to operate this Product in a safe and responsible manner could result in injury or damage to the product or other property. This product is not intended for use by children without direct adult supervision. Do not attempt disassembly, use with incompatible components or augment product in any way without the approval of Horizon Hobby, LLC. This manual contains instructions for safety, operation and maintenance. It is essential to read and follow all the instructions and warnings in the manual, prior to assembly, setup or use, in order to operate correctly and avoid damage or serious injury.

Age Recommendation: Not for children under 14 years. This is not a toy.

WARNING AGAINST COUNTERFEIT PRODUCTS

Always purchase from a Horizon Hobby, LLC authorized dealer to ensure authentic high-quality Spektrum product. Horizon Hobby, LLC disclaims all support and warranty with regards, but not limited to, compatibility and performance of counterfeit products or products claiming compatibility with DSM or Spektrum technology.

NOTICE: This product is only intended for use with unmanned, hobby-grade, remote-controlled vehicles and aircraft. Horizon Hobby disclaims all liability outside of the intended purpose and will not provide warranty service related thereto.

WARRANTY REGISTRATION

Visit www.spektrumrc.com/registration today to register your product.

Spektrum Lap Timing

SPMLTG5000 Gates and SPMLTT2500 Timing Receivers work with Spektrum™ Telemetry equipped radio systems, making it easy to set up a timing system without a personal computer. Compatible with Spektrum™ X-Bus and RPM Telemetry systems. Requires a Spektrum Telemetry capable transmitter and receiver system.

For more information on Spektrum Telemetry visit:
<http://www.spektrumrc.com>

Contents

Specifications	4
Connecting a Battery to the Timing Gate	4
Setting up the SPMLTG5000 Gate system	5
Track Setup	6
Connecting the SPMLTT2500	7
Connecting the SPMLTT1000	8
Installing the SPMLTT2500 on a Surface Vehicle	8
Installing the SPMLTT2500 on a quadcopter	9
Transmitter Setup	10
Troubleshooting Guide	11
1-YEAR LIMITED WARRANTY	12
Warranty and Service Contact Information	14

Compatible Spektrum Radio Systems

Air Transmitters	Air Receivers	Surface Transmitters	
DX6e	SPM4649T	DX5R	
DX6 G2, G3	SPMAR6270T		
DX7 G2	SPMAR6600T	Surface Receivers	
DX8 G2	SPMAR7350	SPMSR4000T	
DX9, DX9 Stealth	SPMAR8010T	SPMSR6000T	
DX18, DX18 G2, DX18 Stealth	SPMAR9030T		
	SPMAR9320T	Add-on Telemetry Modules	
	SPMAR9350	Air	SPM9549*
			SPM9548
		Surface	SPM6742

*3 pin connector required

Specifications

Specifications	SPMLTG5000
Type	Lap Timing System- Gate
Dimensions (LxWxH)	51 x 31 x 16mm
Weight	14g
IR source	5 individual IR LEDs
Input Voltage	3S LiPo (Balance Connector)
Compatibility	SPMLTT1000, SPMLTT2500

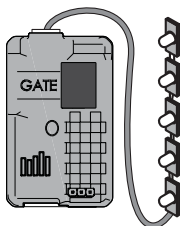

Specifications	SPMLTT2500
Type	Lap Timing System- IR Receiver
Dimensions (LxWxH)	23 x 23 x 12mm
Weight	5g
Input Voltage	4–8.4V
Compatibility	SPM9549, SPM9548, SPM4649T

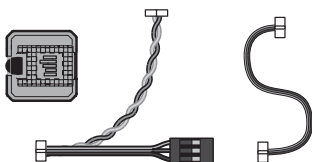

Connecting a Battery to the Timing Gate

Power the SPMLTG5000 with a 3S LiPo battery from the JST XH balance lead. Insert the balance connector into the port on the bottom of the case to power on the gate.

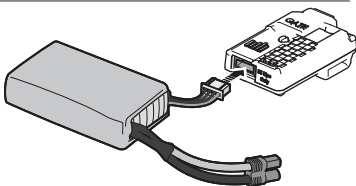

Setting up the SPMLTG5000 Gate system

The Infrared (IR) LEDs need to be strung up facing across the race track. The light beam from the IR LEDs is the virtual “gate” that will trigger the timing system when the SPMLTT2500 passes.

IR LEDs may be attached to existing race gates, fence poles, or similar. Horizon Hobby racing gates FPV10604 and FPV10605 feature eyelets which can be utilized to hold the IR LEDs with a zip tie.

Tip: A simple stand to hold the timing system can be built with common PVC material available from local hardware stores.

QTY	Materials for vertical PVC gate assembly (not included)
1	5 foot length of 1/2 inch PVC
6	12 inch sections of 1/2 inch PVC tube
3	1/2 inch PVC T-Fittings

Assemble the timing stand as shown and attach the timing system using double sided tape and straps with hook and loop material. Glue is usually not necessary to assemble to PVC pipes, which also makes it easy to disassemble for transport.

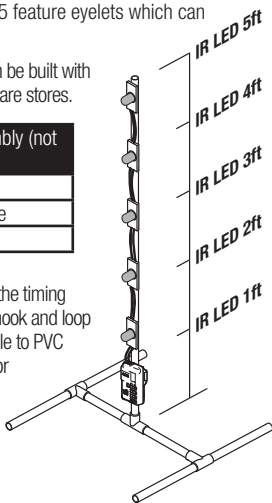

QTY	Materials for horizontal PVC gate assembly (not included)
1	length of 1/2 inch PVC (sized to width of track)
6	18 inch sections of 1/2 inch PVC tube
2	1/2 inch PVC 90° elbows
2	1/2 inch PVC T-Fittings

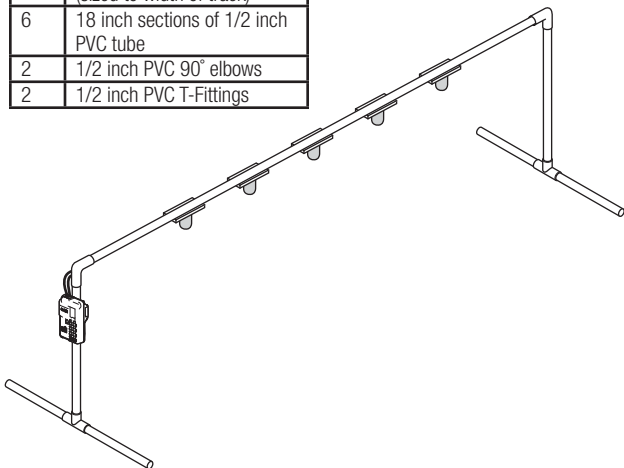

Track Setup

Set up vertical timing gate(s) on an outside section of the track, facing outward across the track. Pointing the IR LEDs toward the center of the track may cause incorrect lap timing readings.

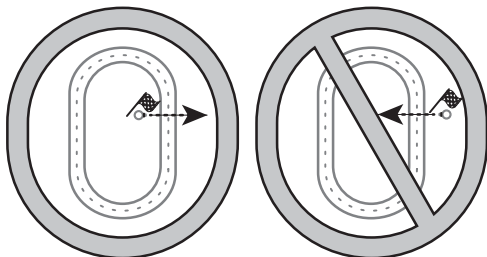

Additional timing gates may be set up along the track at intervals to define lap segments. Up to 9 lap segments may be added in addition to the finish line gate.

When first powered up, the 7 segment display will show your current voltage in single digits, starting with the first digit.

For example: If the battery voltage is 11.54V, it will first display **1**, then flash and show the second digit **1**, then the third digit **5**, and then the final digit **4**.

After the voltage is shown, the display on the base unit will alternate between the Gate number and Power Level. Power Level is designated by an illuminated decimal point. No decimal indicates the Gate number. When the display is alternating between the Gate and Power settings, the base unit is in normal operation mode.

Press and hold the button to enter the settings menu and change between menu points. When the numbers displayed are solid, the base unit is in the settings menu. Use a short press to change values. To save settings and exit back to the normal operation mode, press and hold the button.

The Gate can be set for the gate number to define the start/finish gate and lap segments. Up to 10 gates can be used. The Start/Finish gate is **0**.

Add up to 9 more SPMLTG5000 gates, with each segment set to their own number.* Lap segments are indicated in numerical order:

The Power Level can be adjusted to suit the environment.

- Bright sunny days will need high Power Level settings
- Indoor settings will need lower settings.

TIP: Turn the Power Level up for missed timing, turn the Power Level down if the system is triggering the timer when it shouldn't.

* RPM based timing can only support the start/finish gate, and cannot support additional timing gates for lap segments.

Low Voltage Cutoff for the SPMLTG5000

The SPMLTG5000 will go into a low voltage mode if the battery voltage drops below 10 volts. It will cease operation and begin alternating between “L” and “B” on the display to indicated low battery.

Connecting the SPMLTT2500

There are two methods to connect the Lap Timing Receiver to Spektrum telemetry receivers.

1. For telemetry systems featuring an X-Bus connection, simply connect a 4-pin X-Bus to X-Bus cable between the Timing Receiver and the X-Bus telemetry connector on the Telemetry device

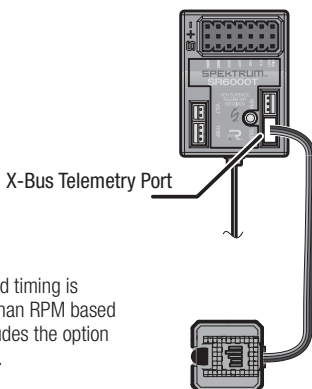

Tip: X-Bus based timing is more accurate than RPM based timing, and includes the option of lap segments.

2. The timing system can also utilize the RPM input for timing. Use the included harness to connect the Lap timing sensor to the RPM port or Lap timing port on receivers such as the SPM4649T. When using this configuration, you must connect a 5V power supply to the SPMLTT2500.

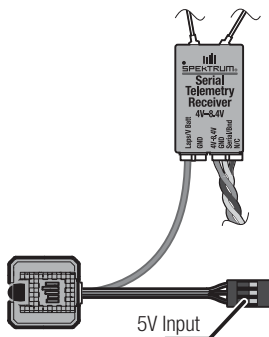

Connecting the SPMLTT1000

The Spektrum SPMFCF400 flight controller can be used directly with the SPMLTT1000 sensor. When the flight controller is paired with the SPM4649T receiver, the flight controller can send the lap timing information to the receiver with the standard 3-wire receiver connection without any additional wiring.

Install the sensor from the top and solder the pins on the bottom of the flight controller. The sensor should face out the left side of the quadcopter when mounted to the flight controller.

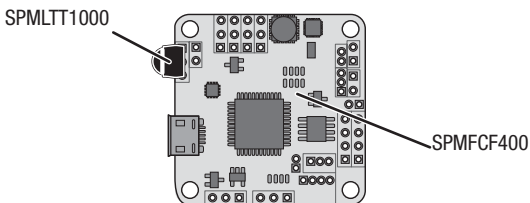

Tip: The SPMFCF400 paired with the SPMLTT1000 uses the **Lap Counter** telemetry function, delivering the same performance and features as X-Bus based systems. This combination is the lightest, simplest solution to add Spektrum lap timing on a quadcopter.

Installing the SPMLTT2500 on a Surface Vehicle

For surface applications, the sensor must be mounted where it can have a visible line of sight to the Timing Gate in a window or on top of the vehicle. Select a vertical or Horizontal gate configuration, and install the sensor to suit. The sensor should point left or right for a vertical Timing Gate, and straight up for a Horizontal Timing Gate.

Sensor Installation for Vertical Timing Gate

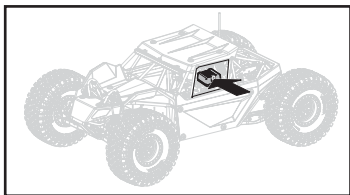

Sensor Installation for Horizontal Timing Gate

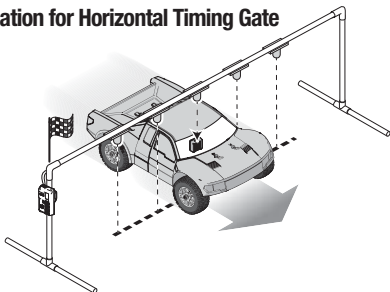

Installing the SPMLTT2500 on a quadcopter

Install the IR receiver with double-sided tape or adhesive-backed hook and loop material. The IR receiver must face the IR LEDs as the vehicle passes the timing gate.

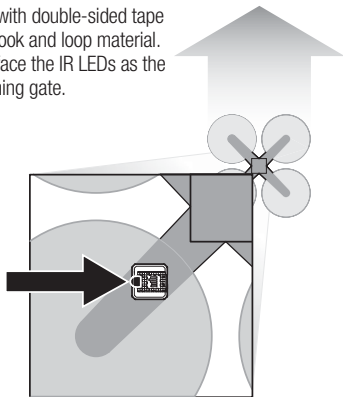

IMPORTANT: The IR receiver sensor must point toward the timing gate as it passes the gate. Do not mount the sensor pointed forward or backward.

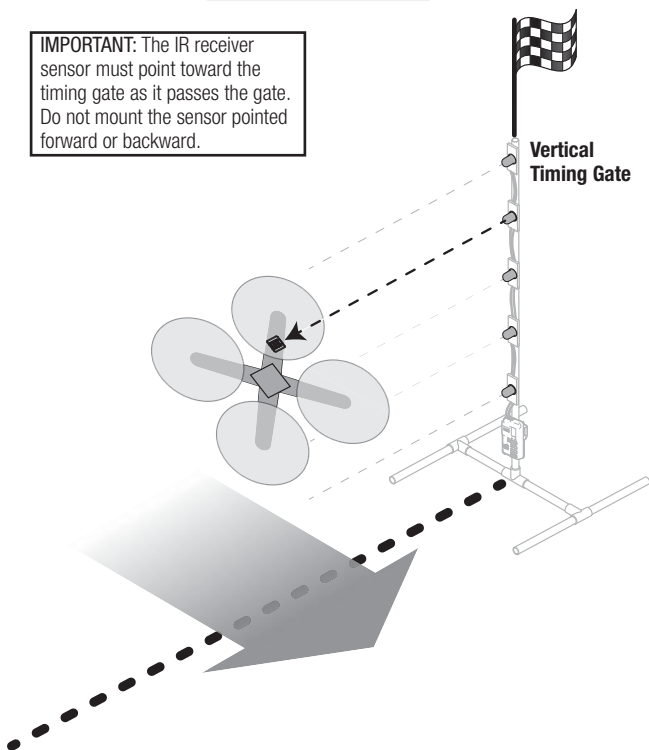

Transmitter Setup

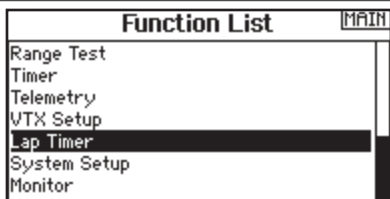

Always use the latest transmitter updates available at SpektrumRC.com.

1. Select the Lap Timer menu in the Function List.



2. Configure the timer mode and set the maximum number of laps.
3. In the Telemetry selection, choose **LAP COUNTER** if the sensor is connected to the X-Bus connection or flight controller, or **RPM** if the sensor is connected to an RPM input.

IMPORTANT: Select **RPM** when using the SPM4649T telemetry receiver with the SPMLT2500.

4. To log lap times onto an SD card, determine the file name and change the option for **Enabled?** to **Yes**.
5. Select **NEXT** to choose event reporting options. This is where to configure how and when the transmitter reports lap times (vibration, tone, voice).

Lap Timer Telemetry Screen

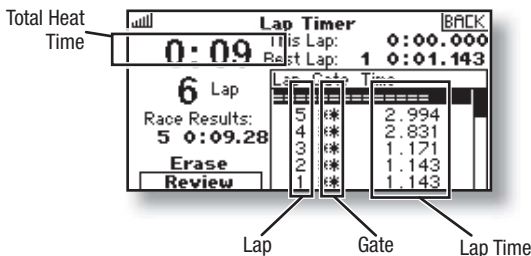

6. Access the Lap timing telemetry menu by scrolling right from the home screen.
7. Select **Review** to view times from previous heats.

Troubleshooting Guide

Problem	Possible Cause	Solution
Missed Timing	Gate battery low	Charge battery
	Obstruction to line of sight	Ensure clear line of site between gate and sensor
	Power level too low	Turn power level up
	Start/Finish gate not set to zero	Set Start/Finish gate as zero for gate number
	Telemetry not configured properly	Ensure Lap counter or RPM input options are set correctly to match your telemetry system. See <i>Connecting the SPMLTT2500</i>
	Sensor pointed directly at the sun	Avoid configuring the track so the sensor is pointed directly into the sun
Picking up timing when it shouldn't	Power level too high	Turn power level down
	Timing gate pointed across track	Place timing gate on outside section of track
	Sensor pointed directly at the sun	Avoid configuring the track so the sensor is pointed directly into the sun

1-YEAR LIMITED WARRANTY

What this Warranty Covers - Horizon Hobby, LLC, (Horizon) warrants to the original purchaser that the product purchased (the "Product") will be free from defects in materials and workmanship for a period of 1 year from the date of purchase.

What is Not Covered

This warranty is not transferable and does not cover (i) cosmetic damage, (ii) damage due to acts of God, accident, misuse, abuse, negligence, commercial use, or due to improper use, installation, operation or maintenance, (iii) modification of or to any part of the Product, (iv) attempted service by anyone other than a Horizon Hobby authorized service center, (v) Product not purchased from an authorized Horizon dealer, (vi) Product not compliant with applicable technical regulations, or (vii) use that violates any applicable laws, rules, or regulations.

OTHER THAN THE EXPRESS WARRANTY ABOVE, HORIZON MAKES NO OTHER WARRANTY OR REPRESENTATION, AND HEREBY DISCLAIMS ANY AND ALL IMPLIED WARRANTIES, INCLUDING, WITHOUT LIMITATION, THE IMPLIED WARRANTIES OF NON-INFRINGEMENT, MERCHANTABILITY AND FITNESS FOR A PARTICULAR PURPOSE. THE PURCHASER ACKNOWLEDGES THAT THEY ALONE HAVE DETERMINED THAT THE PRODUCT WILL SUITABLY MEET THE REQUIREMENTS OF THE PURCHASER'S INTENDED USE.

Purchaser's Remedy

Horizon's sole obligation and purchaser's sole and exclusive remedy shall be that Horizon will, at its option, either (i) service, or (ii) replace, any Product determined by Horizon to be defective. Horizon reserves the right to inspect any and all Product(s) involved in a warranty claim. Service or replacement decisions are at the sole discretion of Horizon. Proof of purchase is required for all warranty claims. SERVICE OR REPLACEMENT AS PROVIDED UNDER THIS WARRANTY IS THE PURCHASER'S SOLE AND EXCLUSIVE REMEDY.

Limitation of Liability

HORIZON SHALL NOT BE LIABLE FOR SPECIAL, INDIRECT, INCIDENTAL OR CONSEQUENTIAL DAMAGES, LOSS OF PROFITS OR PRODUCTION OR COMMERCIAL LOSS IN ANY WAY, REGARDLESS OF WHETHER SUCH CLAIM IS BASED IN CONTRACT, WARRANTY, TORT, NEGLIGENCE, STRICT LIABILITY OR ANY OTHER THEORY OF LIABILITY, EVEN IF HORIZON HAS BEEN ADVISED OF THE POSSIBILITY OF SUCH DAMAGES. Further, in no event shall the liability of Horizon exceed the individual price of the Product on which liability is asserted. As Horizon has no control over use, setup, final assembly, modification or misuse, no liability shall be assumed nor accepted for any resulting damage or injury. By the act of use, setup or assembly, the user accepts all resulting liability. If you as the purchaser or user are not prepared to accept the liability associated with the use of the Product, purchaser is advised to return the Product immediately in new and unused condition to the place of purchase.

Law

These terms are governed by Illinois law (without regard to conflict of law principals). This warranty gives you specific legal rights, and you may also have other rights which vary from state to state. Horizon reserves the right to change or modify this warranty at any time without notice.

WARRANTY SERVICES

Questions, Assistance, and Services

Your local hobby store and/or place of purchase cannot provide warranty support or service. Once assembly, setup or use of the Product has been started, you must contact your local distributor or Horizon directly. This will enable Horizon to

better answer your questions and service you in the event that you may need any assistance. For questions or assistance, please visit our website at www.horizonhobby.com, submit a Product Support Inquiry, or call the toll free telephone number referenced in the Warranty and Service Contact Information section to speak with a Product Support representative.

Inspection or Services

If this Product needs to be inspected or serviced and is compliant in the country you live and use the Product in, please use the Horizon Online Service Request submission process found on our website or call Horizon to obtain a Return Merchandise Authorization (RMA) number. Pack the Product securely using a shipping carton. Please note that original boxes may be included, but are not designed to withstand the rigors of shipping without additional protection. Ship via a carrier that provides tracking and insurance for lost or damaged parcels, as Horizon is not responsible for merchandise until it arrives and is accepted at our facility. An Online Service Request is available at http://www.horizonhobby.com/content/_service-center_render-service-center. If you do not have internet access, please contact Horizon Product Support to obtain a RMA number along with instructions for submitting your product for service. When calling Horizon, you will be asked to provide your complete name, street address, email address and phone number where you can be reached during business hours. When sending product into Horizon, please include your RMA number, a list of the included items, and a brief summary of the problem. A copy of your original sales receipt must be included for warranty consideration. Be sure your name, address, and RMA number are clearly written on the outside of the shipping carton.

NOTICE: Do not ship LiPo batteries to Horizon. If you have any issue with a LiPo battery, please contact the appropriate Horizon Product Support office.

Warranty Requirements

For Warranty consideration, you must include your original sales receipt verifying the proof-of-purchase date. Provided warranty conditions have been met, your Product will be serviced or replaced free of charge. Service or replacement decisions are at the sole discretion of Horizon.

Non-Warranty Service

Should your service not be covered by warranty, service will be completed and payment will be required without notification or estimate of the expense unless the expense exceeds 50% of the retail purchase cost. By submitting the item for service you are agreeing to payment of the service without notification. Service estimates are available upon request. You must include this request with your item submitted for service. Non-warranty service estimates will be billed a minimum of ½ hour of labor. In addition you will be billed for return freight. Horizon accepts money orders and cashier's checks, as well as Visa, MasterCard, American Express, and Discover cards. By submitting any item to Horizon for service, you are agreeing to Horizon's Terms and Conditions found on our website http://www.horizonhobby.com/content/_service-center_render-service-center.

ATTENTION: Horizon service is limited to Product compliant in the country of use and ownership. If received, a non-compliant Product will not be serviced. Further, the sender will be responsible for arranging return shipment of the un-serviced Product, through a carrier of the sender's choice and at the sender's expense. Horizon will hold non-compliant Product for a period of 60 days from notification, after which it will be discarded.

Warranty and Service Contact Information

Country of Purchase	Horizon Hobby	Contact Information	Address
United States of America	Horizon Service Center (Repairs and Repair Requests)	servicecenter.horizonhobby.com/RequestForm/	4105 Fieldstone Rd Champaign, Illinois, 61822 USA
	Horizon Product Support (Product Technical Assistance)	productsupport@horizonhobby.com. 877-504-0233	
		Sales	
EU	Horizon Technischer Service	service@horizonhobby.eu	Hanskampring 9 D 22885 Barsbüttel, Germany
	Sales: Horizon Hobby GmbH	+49 (0) 4121 2655 100	

CE **EU Compliance Statement:** Horizon Hobby, LLC hereby declares that this product is in compliance with the essential requirements and other relevant provisions of the EMC directive.

A copy of the EU Declaration of Conformity is available online at:
<http://www.horizonhobby.com/content/support-render-compliance>.



Instructions for disposal of WEEE by users in the European Union

This product must not be disposed of with other waste. Instead, it is the user's responsibility to dispose of their waste equipment by handing it over to a designated collections point for the recycling of waste electrical and electronic equipment. The separate collection and recycling of your waste equipment at the time of disposal will help to conserve natural resources and ensure that it is recycled in a manner that protects human health and the environment. For more information about where you can drop off your waste equipment for recycling, please contact your local city office, your household waste disposal service or where you purchased the product.



E328

© 2017 Horizon Hobby, LLC. DSM is a registered trademark of Horizon Hobby, LLC.

The Spektrum trademark is used with permission of Bachmann Industries, Inc.

All other trademarks, service marks and logos are property of their respective owners.

Created 08/17

55702.1