

SPEKTRUM®

AR7700 User Guide

AR7700 Bedienungsanleitung

Guide de l'utilisateur - AR7700

AR7700 Guida dell'utente

NOTICE

All instructions, warranties and other collateral documents are subject to change at the sole discretion of Horizon Hobby, LLC. For up-to-date product literature, visit horizonhobby.com and click on the support tab for this product.

Meaning of Special Language

The following terms are used throughout the product literature to indicate various levels of potential harm when operating this product:

NOTICE: Procedures, which if not properly followed, create a possibility of physical property damage AND a little or no possibility of injury.

CAUTION: Procedures, which if not properly followed, create the probability of physical property damage AND a possibility of serious injury.

WARNING: Procedures, which if not properly followed, create the probability of property damage, collateral damage, and serious injury OR create a high probability of superficial injury.



WARNING: Read the ENTIRE instruction manual to become familiar with the features of the product before operating. Failure to operate the product correctly can result in damage to the product, personal property and cause serious injury.

This is a sophisticated hobby product. It must be operated with caution and common sense and requires some basic mechanical ability. Failure to operate this Product in a safe and responsible manner could result in injury or damage to the product or other property. This product is not intended for use by children without direct adult supervision. Do not attempt disassembly, use with incompatible components or augment product in any way without the approval of Horizon Hobby, LLC. This manual contains instructions for safety, operation and maintenance. It is essential to read and follow all the instructions and warnings in the manual, prior to assembly, setup or use, in order to operate correctly and avoid damage or serious injury.

Age Recommendation: Not for children under 14 years. This is not a toy.

WARNING AGAINST COUNTERFEIT PRODUCTS

Always purchase from a Horizon Hobby, LLC authorized dealer to ensure authentic high-quality Spektrum product. Horizon Hobby, LLC disclaims all support and warranty with regards, but not limited to, compatibility and performance of counterfeit products or products claiming compatibility with DSM or Spektrum.

NOTICE: This product is only intended for use with unmanned, hobby-grade, remote-controlled vehicles and aircraft. Horizon Hobby disclaims all liability outside of the intended purpose and will not provide warranty service related thereto.

WARRANTY REGISTRATION

Visit www.spektrumrc.com/registration today to register your product.

AR7700 Instruction Manual

The AR7700 full range receiver features DSM[®] technology and is compatible with all Spektrum[™] and JR[®] aircraft radios that support DSM2[®] and DSMX[®] technology.

Features

- 8 channel 22ms PPM output*
- 18 channel 11ms SRXL output*
- 18 channel 11ms Remote Receiver output*
- Gear, Aux 1 and Aux 2 (Channels 5,6, and 7) are output in parallel as normal PWM servo signals
- Flight Log and telemetry compatible

*Note: The receiver can only output the number of channels the transmitter can support.

Applications

Multicopter and FPV projects that can take advantage of a serial signal to reduce wiring clutter. Not for use in aircraft that require conventional PWM servo connections for flight control.

Specifications

Type: DSM Full Range Receiver

Channels: 8–18

Modulation: DSM2, DSMX

Band: 2.4GHz

Dimension (WxLxH): 1.15 x 1.35 x 0.45 in (29.2 x 34.3 x 11.4mm)

Weight: 1.4 oz (8.9 g)

Input Voltage Range: 3.5–9.6V

Compatibility: All DSM2 and DSMX Aircraft Transmitters and Module Systems

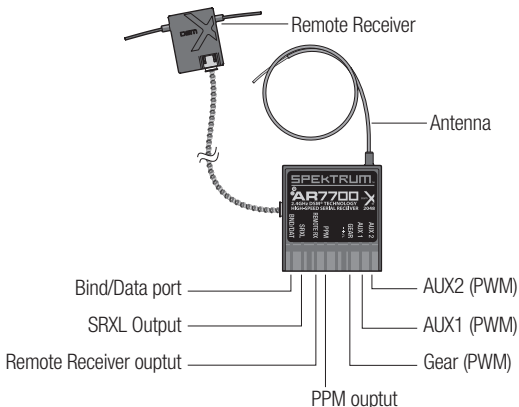

Installing the Receiver

1. Locate a flat spot on the airframe where you can install the receiver.
2. Mount the Receiver using high-quality, double sided foam tape. The receiver must be mounted securely to prevent it from moving in flight.

Important: Y-Harnesses and Servo Extensions

When using a Y-harness or servo extensions in your installation, it's important to use standard non-amplified Y-harnesses and servo extensions as this can/will cause the servos to operate erratically or not function at all. Amplified Y-harnesses were developed several years ago to boost the signal for some older PCM systems and should not be used with Spektrum equipment. Note that when converting an existing model to Spektrum, be certain that all amplified Y-harnesses and/or servo extensions are replaced with conventional non-amplified versions.

Antenna placement and Polarization

The long antenna on the AR7700 employs a coax cable to help with antenna implementation. Only the tip of the antenna with the exposed center element is the active portion of the antenna. For optimal performance use an antenna tube or other method to mount the active portion of the antenna as far as possible from any carbon fiber, metal or wiring. The AR7700 will operate without the remote receiver, but should be considered a parkflyer receiver if used without the remote receiver. For full range performance, antenna placement of both the coax antenna and the remote receiver antenna is critical.

Binding

The AR7700 receiver must be bound to the transmitter before it will operate. Binding is the process of teaching the receiver the specific code of the transmitter so it will only connect to that specific transmitter.

1. Connect the remote receiver to the main receiver. The remote receiver is required for operation.
2. Insert the bind plug in the BIND/PROG port on the receiver.
3. Power the receiver through any open channel port. The orange LED on the receiver flashes, indicating the receiver is in bind mode.
4. Put the transmitter in bind mode. Binding is complete when the orange LED on the receiver is solid.
5. Remove the bind plug from the BIND/PROG port on the receiver before you power off the transmitter and store it in a convenient place.

NOTICE: Remove the bind plug to prevent the system from entering bind mode the next time the power is turned on.

6. After you set up your model, always rebind the transmitter and receiver to set the desired failsafe positions.

Normal Remote Receiver Failsafe

In this mode the remote receiver output from the AR7700 operates like any normal remote receiver in that it will not send failsafe commands. This requires the host device to be able to detect a failsafe condition and configure failsafe operation. If you want to operate your system in this mode, leave the bind plug in during the bind procedure. Always remove the bind plug before subsequent power cycles or you will have to re-bind.

Preset Failsafe

When the transmitter and receiver are turned on, the receiver connects to the transmitter and normal control of all channels occurs. If loss of signal occurs, the failsafe function moves all control outputs to preset positions that were set during binding. When the receiver detects signal from the transmitter, normal aircraft operation resumes.

Setting the Failsafe Positions

During the binding process the stick and switch positions will be set as the preset failsafe positions.

1. Insert the bind plug in the bind port before powering on the receiver.
2. Power on the receiver. A flashing orange LED indicates the receiver is in Bind mode.
3. Unplug the bind plug before binding.
4. Power on your transmitter with the bind button depressed and the sticks and switches in the desired failsafe positions.

PPM Output

This mode connects with flight control systems that accept a PPM data stream. This protocol is widely available in many flight controllers, but is not as fast or offer as many channels, Remote Receiver Output or SRXL.

SRXL output

SRXL is a high speed digital protocol that compares favorably with remote receiver output. If your flight control system offers SRXL, this option is preferred over PPM for its high speed performance.

Remote Receiver Output

Remote receiver output requires normal 3.5-9.6V power to be supplied to the AR7700. The AR7700 cannot operate from the power supply normally available to power a single remote receiver directly.

The Remote Receiver output available on the AR7700 connects to flight control systems that accept a Spektrum remote receiver. Do not connect the remote output to the remote receiver port on a conventional Spektrum receiver.

Range Testing

Before each flying session and especially with a new model, it is important to perform a range check. All Spektrum aircraft transmitters incorporate a range testing system which, when activated, reduces the output power.

1. With the model restrained on the ground, stand 30 paces (approx. 90 feet/28 meters) away from the model.
2. Face the model with the transmitter in your normal flying position and place your transmitter into range check mode.
3. You should have total control of the model with the button depressed at 30 paces (90 feet/28 meters).
4. If control issues exist, contact the appropriate product support department.

Receiver Power System Requirements

Inadequate power systems that are unable to provide the necessary minimum voltage to the receiver during flight have become the number one cause of in-flight failures. Some of the power system components that affect the ability to properly deliver adequate power include:

- Receiver battery pack (number of cells, capacity, cell type, state of charge)
- The ESC's capability to deliver current to the receiver in electric aircraft
- The switch harness, battery leads, servo leads, regulators etc.

The AR7700 has a minimum operational voltage of 3.5 volts; it is highly recommended the power system be tested per the guidelines below.

Recommended Power System Test Guidelines

If the system is sharing a power supply with servos or a camera gimbal, it is recommended that a voltmeter be used to perform the following tests.

The Hangar 9[®] Digital Servo & Rx Current Meter (HAN172), Spektrum Flight Log (SPM9540), TM1100 or TM1000 telemetry modules are excellent tools to perform the test below.

Plug the voltmeter into an open channel port in the receiver and with the system on, or simply monitor the voltage on a telemetry capable transmitter, load the control surfaces (apply pressure with your hand) while monitoring the voltage at the receiver. The voltage should remain above 4.8 volts even when all servos are heavily loaded.



CAUTION: The latest generations of Nickel-Metal Hydride batteries incorporate a new chemistry mandated to be more environmentally friendly. These batteries, when charged with peak detection fast chargers, have tendencies to false peak (not fully charge) repeatedly. These include all brands of NiMH batteries. If using NiMH packs, be especially cautious when charging, making absolutely sure that the battery is fully charged. It is recommended to use a charger that can display total charge capacity. Note the number of mAh put into a discharged pack to verify it has been charged to full capacity.

How QuickConnect™ Technology Works

- When the receiver voltage drops below 3.5 volts the system ceases to operate.
- When power is restored the receiver immediately attempts to reconnect.
- If the transmitter was left on, the system reconnects typically in about 4/100 of a second.

QuickConnect with Brownout Detection is designed to allow you to fly safely through most short duration power interruptions, however, the root cause of these interruptions must be corrected before the next flight to prevent a crash.

NOTICE: If a brownout occurs in flight it is vital that the cause of the brownout be determined and corrected.

Flight Log (SPM9540 Optional)

The Flight Log is compatible with the AR7700. The Flight Log displays overall RF link performance as well as the individual internal and external receiver link data. Additionally it displays receiver voltage.

ModelMatch™ Technology

Some Spektrum transmitters offer a patent pending feature called ModelMatch. ModelMatch technology prevents the possibility of operating a model using the wrong model memory, potentially preventing a crash. With ModelMatch, each model memory has its own unique code (GUID) and during the binding process the code is programmed into the receiver. Later, when the system is turned on, the receiver will only connect to the transmitter if the corresponding model memory is programmed on screen.

If at any time you turn on the system and it fails to connect, check to be sure the correct model memory is selected in the transmitter. Please note that the DX4, DX5e and Aircraft Modules do not have ModelMatch technology.

Frequently Asked Questions on Spektrum 2.4GHz

1. Q: After I've bound the receiver to my transmitter, which do I turn on first when I want to fly?

A: Either one. Every DSM 2.4GHz transmitter has a GUID (Globally Unique Identifier) code imbedded in its signal. When you bind a DSM receiver to your transmitter, this GUID code is stored in the receiver. If you turn the receiver on before the transmitter, you don't have to worry about it responding to another transmitter. The receiver will go into failsafe mode while it waits for a signal from the transmitter with the same GUID code it has stored. See the Receiver Power Only section for more information. If a DSM transmitter is turned on first you can expect it to connect within 6 seconds of powering on the receiver.

2. Q: Sometimes the system takes longer to connect or doesn't connect at all. Why?

A: In order for a DSM system to connect, the receiver must receive a large number of uninterrupted signal packets from the transmitter. This process takes just a few seconds, but if the transmitter is too close to the receiver (within 4 feet) or near reflective material (metal objects, carbon fiber material, etc.) it may detect its own reflected 2.4GHz energy as "noise". This can delay or prevent connection. If this happens, make sure you are a sufficient distance from metal objects and the receiver itself before you power up and try again.

3. Q: How important is it that I test my system using a Spektrum Flight Log?

A: All 2.4GHz signals, not just DSM, are affected by proximity to conductive materials such as carbon fiber or metal. If you are flying a model that uses a lot of conductive materials in its construction, a Flight Log can be helpful. The information it collects when you fly will help you determine the optimum location for your receiver(s) so you can minimize the effects of these materials on your signal performance. For more details on the Flight Log and how it works, visit SpektrumRC.com.

1-YEAR LIMITED WARRANTY

What this Warranty Covers - Horizon Hobby, LLC, (Horizon) warrants to the original purchaser that the product purchased (the "Product") will be free from defects in materials and workmanship for a period of 1 year from the date of purchase.

What is Not Covered

This warranty is not transferable and does not cover (i) cosmetic damage, (ii) damage due to acts of God, accident, misuse, abuse, negligence, commercial use, or due to improper use, installation, operation or maintenance, (iii) modification of or to any part of the Product, (iv) attempted service by anyone other than a Horizon Hobby authorized service center, (v) Product not purchased from an authorized Horizon dealer, (vi) Product not compliant with applicable technical regulations, or (vii) use that violates any applicable laws, rules, or regulations.

OTHER THAN THE EXPRESS WARRANTY ABOVE, HORIZON MAKES NO OTHER WARRANTY OR REPRESENTATION, AND HEREBY DISCLAIMS ANY AND ALL IMPLIED WARRANTIES, INCLUDING, WITHOUT LIMITATION, THE IMPLIED WARRANTIES OF NON-INFRINGEMENT, MERCHANTABILITY AND FITNESS FOR A PARTICULAR PURPOSE. THE PURCHASER ACKNOWLEDGES THAT THEY ALONE HAVE DETERMINED THAT THE PRODUCT WILL SUITABLY MEET THE REQUIREMENTS OF THE PURCHASER'S INTENDED USE.

Purchaser's Remedy

Horizon's sole obligation and purchaser's sole and exclusive remedy shall be that Horizon will, at its option, either (i) service, or (ii) replace, any Product determined by Horizon to be defective. Horizon reserves the right to inspect any and all Product(s) involved in a warranty claim. Service or replacement decisions are at the sole discretion of Horizon. Proof of purchase is required for all warranty claims. SERVICE OR REPLACEMENT AS PROVIDED UNDER THIS WARRANTY IS THE PURCHASER'S SOLE AND EXCLUSIVE REMEDY.

Limitation of Liability

HORIZON SHALL NOT BE LIABLE FOR SPECIAL, INDIRECT, INCIDENTAL OR CONSEQUENTIAL DAMAGES, LOSS OF PROFITS OR PRODUCTION OR COMMERCIAL LOSS IN ANY WAY, REGARDLESS OF WHETHER SUCH CLAIM IS BASED IN CONTRACT, WARRANTY, TORT, NEGLIGENCE, STRICT LIABILITY OR ANY OTHER THEORY OF LIABILITY, EVEN IF HORIZON HAS BEEN ADVISED OF THE POSSIBILITY OF SUCH DAMAGES. Further, in no event shall the liability of Horizon exceed the individual price of the Product on which liability is asserted. As Horizon has no control over use, setup, final assembly, modification or misuse, no liability shall be assumed nor accepted for any resulting damage or injury. By the act of use, setup or assembly, the user accepts all resulting liability. If you as the purchaser or user are not prepared to accept the liability associated with the use of the Product, purchaser is advised to return the Product immediately in new and unused condition to the place of purchase.

Law

These terms are governed by Illinois law (without regard to conflict of law principals). This warranty gives you specific legal rights, and you may also have other rights which vary from state to state. Horizon reserves the right to change or modify this warranty at any time without notice.

WARRANTY SERVICES

Questions, Assistance, and Services

Your local hobby store and/or place of purchase cannot provide warranty support or service. Once assembly, setup or use of the Product has been started, you must contact

your local distributor or Horizon directly. This will enable Horizon to better answer your questions and service you in the event that you may need any assistance. For questions or assistance, please visit our website at www.horizonhobby.com, submit a Product Support Inquiry, or call the toll free telephone number referenced in the Warranty and Service Contact Information section to speak with a Product Support representative.

Inspection or Services

If this Product needs to be inspected or serviced and is compliant in the country you live and use the Product in, please use the Horizon Online Service Request submission process found on our website or call Horizon to obtain a Return Merchandise Authorization (RMA) number. Pack the Product securely using a shipping carton. Please note that original boxes may be included, but are not designed to withstand the rigors of shipping without additional protection. Ship via a carrier that provides tracking and insurance for lost or damaged parcels, as Horizon is not responsible for merchandise until it arrives and is accepted at our facility. An Online Service Request is available at http://www.horizonhobby.com/content/_service-center_render-service-center. If you do not have internet access, please contact Horizon Product Support to obtain a RMA number along with instructions for submitting your product for service. When calling Horizon, you will be asked to provide your complete name, street address, email address and phone number where you can be reached during business hours. When sending product into Horizon, please include your RMA number, a list of the included items, and a brief summary of the problem. A copy of your original sales receipt must be included for warranty consideration. Be sure your name, address, and RMA number are clearly written on the outside of the shipping carton.

NOTICE: Do not ship LiPo batteries to Horizon. If you have any issue with a LiPo battery, please contact the appropriate Horizon Product Support office.

Warranty Requirements

For Warranty consideration, you must include your original sales receipt verifying the proof-of-purchase date. Provided warranty conditions have been met, your Product will be serviced or replaced free of charge. Service or replacement decisions are at the sole discretion of Horizon.

Non-Warranty Service

Should your service not be covered by warranty, service will be completed and payment will be required without notification or estimate of the expense unless the expense exceeds 50% of the retail purchase cost. By submitting the item for service you are agreeing to payment of the service without notification. Service estimates are available upon request. You must include this request with your item submitted for service. Non-warranty service estimates will be billed a minimum of ½ hour of labor. In addition you will be billed for return freight. Horizon accepts money orders and cashier's checks, as well as Visa, MasterCard, American Express, and Discover cards. By submitting any item to Horizon for service, you are agreeing to Horizon's Terms and Conditions found on our website http://www.horizonhobby.com/content/_service-center_render-service-center.

ATTENTION: Horizon service is limited to Product compliant in the country of use and ownership. If received, a non-compliant Product will not be serviced. Further, the sender will be responsible for arranging return shipment of the un-serviced Product, through a carrier of the sender's choice and at the sender's expense. Horizon will hold non-compliant Product for a period of 60 days from notification, after which it will be discarded.

Warranty and Service Contact Information

Country of Purchase	Horizon Hobby	Contact Information	Address
United States of America	Horizon Service Center (Repairs and Repair Requests)	servicecenter.horizonhobby.com/ RequestForm/	4105 Fieldstone Rd Champaign, Illinois, 61822 USA
	Horizon Product Support (Product Technical Assistance)	productsupport@horizonhobby.com. 888-959-2305	
	Sales	sales@horizonhobby.com 888-959-2305	
United Kingdom	Service/Parts/ Sales: Horizon Hobby Limited	sales@horizonhobby.co.uk +44 (0) 1279 641 097	Units 1–4, Ployters Rd, Staple Tye, Harlow Essex, CM18 7NS United Kingdom
Germany	Horizon Technischer Service	service@horizonhobby.de	Christian-Junge- Straße 1 25337 Elmshorn, Germany
	Sales: Horizon Hobby GmbH	+49 (0) 4121 2655 100	
France	Service/Parts/ Sales: Horizon Hobby SAS	infofrance@horizonhobby.com +33 (0) 1 60 18 34 90	11 Rue Georges Charpak 77127 Lieusaint, France
China	Service/Parts/ Sales: Horizon Hobby – China	info@horizonhobby.com.cn +86 (021) 5180 9868	Room 506, No. 97 Changshou Rd. Shanghai, China 200060

FCC Information

This device complies with part 15 of the FCC rules. Operation is subject to the following two conditions: (1) This device may not cause harmful interference, and (2) this device must accept any interference received, including interference that may cause undesired operation.



CAUTION: Changes or modifications not expressly approved by the party responsible for compliance could void the user's authority to operate the equipment.

IC Information

This device complies with Industry Canada license-exempt RSS standard(s). Operation is subject to the following two conditions: (1) this device may not cause interference, and (2) this device must accept any interference, including interference that may cause undesired operation of the device.

EU Compliance Statement:

CE Horizon Hobby, LLC hereby declares that this product is in compliance with the essential requirements and other relevant provisions of the R&TTE.

A copy of the EU Declaration of Conformity is available online at:
<http://www.horizonhobby.com/content/support-render-compliance>.



Instructions for disposal of WEEE by users in the European Union

This product must not be disposed of with other waste. Instead, it is the user's responsibility to dispose of their waste equipment by handing it over to a designated collections point for the recycling of waste electrical and electronic equipment. The separate collection and recycling of your waste equipment at the time of disposal will help to conserve natural resources and ensure that it is recycled in a manner that protects human health and the environment. For more information about where you can drop off your waste equipment for recycling, please contact your local city office, your household waste disposal service or where you purchased the product.



E328



© 2015 Horizon Hobby, LLC.

DSM, DSM2, DSMX, QuickConnect, ModelMatch, Hangar 9 and the Horizon Hobby logo are trademarks or registered trademarks of Horizon Hobby, LLC.

The Spektrum trademark is used with permission of Bachmann Industries, Inc.

JR is a registered trademark of JR Americas. All other trademarks, service marks and logos are property of their respective owners.

US 7,391,320. Other patents pending.