



**SPEKTRUM®**

## **AR6400NBL User Guide**

---

**NOTICE**

All instructions, warranties and other collateral documents are subject to change at the sole discretion of Horizon Hobby, Inc. For up-to-date product literature, visit [horizonhobby.com](http://horizonhobby.com) and click on the support tab for this product.

**Meaning of Special Language**

The following terms are used throughout the product literature to indicate various levels of potential harm when operating this product:

**NOTICE:** Procedures, which if not properly followed, create a possibility of physical property damage AND a little or no possibility of injury.

**CAUTION:** Procedures, which if not properly followed, create the probability of physical property damage AND a possibility of serious injury.

**WARNING:** Procedures, which if not properly followed, create the probability of property damage, collateral damage, and serious injury OR create a high probability of superficial injury.



**WARNING:** Read the ENTIRE instruction manual to become familiar with the features of the product before operating. Failure to operate the product correctly can result in damage to the product, personal property and cause serious injury.

This is a sophisticated hobby product. It must be operated with caution and common sense and requires some basic mechanical ability. Failure to operate this Product in a safe and responsible manner could result in injury or damage to the product or other property. This product is not intended for use by children without direct adult supervision. Do not attempt disassembly, use with incompatible components or augment product in any way without the approval of Horizon Hobby, Inc. This manual contains instructions for safety, operation and maintenance. It is essential to read and follow all the instructions and warnings in the manual, prior to assembly, setup or use, in order to operate correctly and avoid damage or serious injury.

**WARNING AGAINST COUNTERFEIT PRODUCTS**

Thank you for purchasing a genuine Spektrum product. Always purchase from a Horizon Hobby, Inc. authorized dealer to ensure authentic high-quality Spektrum product. Horizon Hobby, Inc. disclaims all support and warranty with regards, but not limited to, compatibility and performance of counterfeit products or products claiming compatibility with DSM or Spektrum technology.

**Age Recommendation: Not for children under 14 years. This is not a toy.**

**WARRANTY REGISTRATION**

Visit [www.spektrumrc.com/registration](http://www.spektrumrc.com/registration) today to register your product.

# AR6400NBL User Guide

The AR6400NBL 6-channel Ultra Micro Receiver with brushless speed control and X-Port™ technology is designed for ultra micro aircraft. Featuring DSM2™ technology, the AR6400NBL is compatible with all Spektrum™, JR®, E-flite® and ParkZone® 2.4GHz DSM2 technology transmitters.

**NOTICE:** The AR6400NBL receiver is not compatible with the DX6 parkflyer radio system.

## Features

- **6-channel ultra micro receiver**
- **Integrated programmable brushless speed control**
- **Weighs just 7.8 grams**
- **Compatible with optional Spektrum ultra micro linear servos; 1.5-gram (SPMAS2000) servo and 1.7-gram (SPMAS2000L)**
- **Smart Bind™ technology**
- **X-Port allows for future expansion**

## Applications

The AR6400NBL is designed for ultra micro aircraft and is ideal for scratch-built ultra micro projects. The AR6400NBL is designed to utilize a two-cell LiPo battery. You can use the integrated brushless speed controller to power a brushless motor up to 3 amps of continuous current. An integrated X-Port feature allows for future expansion.

When X-Port is active, CH5 and CH6 are not available; however, reversed aileron (CH2) is still available.

### AR6400NBL Specifications:

**Type:** DSM2 ultra micro receiver with integrated brushless speed controller

**Channels:** 6 or 4 channels, plus X-Port

**Modulation:** DSM2

**Dimension (WxLxH):** 37.60 x 28.55 x 8.00mm

**Weight:** 7.8 g

**Input Voltage Range:** 2-cell LiPo 6.4 to 8.4V

**Antenna Length:** 31mm

**Resolution:** 1024

**Compatibility:** All DSM2 aircraft transmitters

### Speed Controller:

**Type:** Integrated programmable brushless

**Max continuous current:** 3.0 amps

**Overload protection current:** 5A for 500ms

**BEC continuous current:** 1A

**BEC overload protection current:** 1A, 4.2V

**Low-voltage cutoff:** At <6.3V, the motor begins to pulse

At <6.1V, the motor cuts off and the LED flashes

**Over-current protection:** At 3.5A, the motor cuts off until the throttle stick is pulled down to idle

**Temperature protection:** 120C motor cuts off

**Programming features:** See "Programming the Brushless ESC"

## AR6400NBL Features and Ports

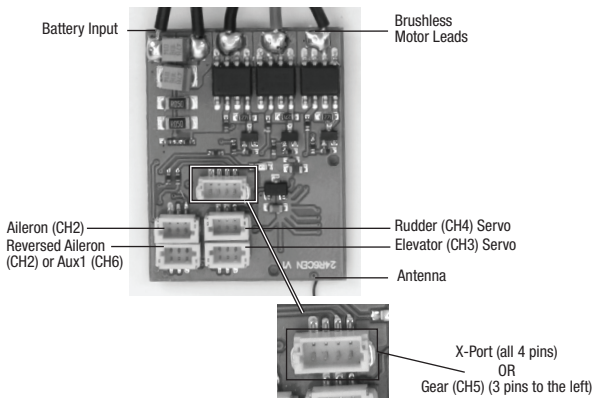

## Receiver Installation

We recommend using double-sided foam tape strips and/or minimal hot glue in the corners to install your receiver in the fuselage. The servos must be in the appropriate position to attach to and drive the elevator and rudder pushrods. Installation will vary depending upon application.



## Servos

Specially designed servos are available through Spektrum.

**NOTICE:** Using any other servo(s) may cause damage to the receiver and/or void the servo warranty.

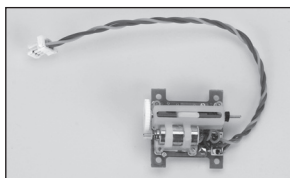
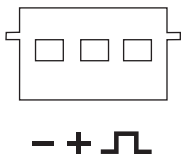

Optional Servos (SPMAS2000/SPMAS2000L)

## Installing and Plugging in the Optional Servos

Use double-sided foam tape strips and/or minimal hot glue to mount the servos in place. The servos must be in the appropriate position to attach to the corresponding pushrods. Plug the servo leads into the appropriate servo ports in the receiver, noting the polarity of the servo connector. Installation will vary depending on application.

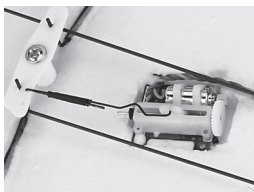

## Smart Bind™

You must first bind the receiver to the transmitter for it to operate. Binding is programming the receiver of the control unit to recognize the GUID (Globally Unique Identifier) code of a single specific transmitter. The AR6400NBL features Smart Bind. When the receiver is first powered, the receiver looks for the signal of its previously bound transmitter for 5 seconds. If no signal is found, the receiver automatically goes into bind mode, indicated by a flashing LED.

## Binding

1. Make sure the flight battery is fully charged.
2. Confirm the flight battery is disconnected from the receiver/ESC unit and the transmitter is turned off.
3. Plug the flight battery into the receiver's battery connector. After 5 seconds, the LED on the receiver begins to flash.
4. After verifying the LED is flashing on the receiver, bind the receiver to the transmitter.
5. If you entered bind mode correctly, you will see a solid LED within about 10 seconds. You should now be bound to the transmitter and have full control and function.

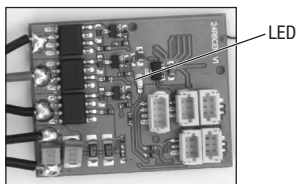

## Transmitter Specific Binding Instructions

1. To bind the AR6400NBL to the transmitter, plug the battery into the receiver. The LED on the receiver will begin flashing.
2. Move the sticks and switches on the transmitter to the desired failsafe positions (low throttle and neutral control positions).
3. Put the transmitter in bind mode. Refer to your transmitter instruction manual for more information.
4. The LED on the receiver will turn solid and the system will connect after several seconds.

**IMPORTANT:** Once the system is bound, ALWAYS turn the transmitter on first and then the receiver to prevent the receiver from re-entering bind mode. If your receiver inadvertently enters bind mode, unplug the battery from the receiver and reinstall with the transmitter turned on.

## Advanced Programming Features

**NOTICE:** To make these changes, enlist the use of a helper to either hold the aircraft to prevent unintended flyaways or to make the changes on the transmitter.

**CAUTION:** Make sure your receiver is off BEFORE making any advanced programming changes in order to prevent the motor from arming.

The following programming features are only recommended for advanced radio users. The photos in this section show the E-flite MLP4DSM transmitter; however, the procedures apply to all compatible transmitters.

## Computer Transmitters

Prior to making any advanced programming feature changes, it is necessary to:

1. Choose an empty model location.
2. Select model type ACRO.
3. Perform a model reset.
4. Set all channels to normal.
5. Ensure transmitter and receiver are bound.

**CAUTION:** Secure the aircraft safely to a work bench or enlist the use of a helper while accessing the advanced programming features. Mistakes in programming could cause the motor to run unexpectedly, which could result in a crash.

### Reversing Servos

Servo reversing is done through your transmitter's servo reversing function. You may also reverse the actual servos by following the instructions below.

### Reversing 1.5-Gram/1.7-Gram Servo

Reversing the servo is useful when implementing certain installations, such as dual ailerons, flaps, etc. Spektrum offers a servo reversing lead that you can plug in between the receiver and the optional servo.

To reverse the servo using the reversing lead:

1. Plug the reversing lead into the servo
2. Plug the servo into the servo port(s)
3. Power the receiver using a charged battery
4. Once the receiver connects, the servo is now reversed
5. Disconnect the battery from the receiver
6. Remove the servo reversing lead (be sure to store your reversing lead in a safe place for future use)
7. Reinstall the servo lead into the servo port(s)



## To Change CH6 to a Reversed CH2 for Dual Ailerons or Reversed CH2 to CH6

1. Ensure the receiver and transmitter are bound
2. Turn the transmitter on
3. Move the THRO stick to the full throttle position
4. Move the Control sticks to the corresponding position to change between the available options (see illustration)
5. Hold this position and plug the battery into the receiver
6. The LED on the receiver will turn solid within 5 seconds and the LED will flash 3 times, indicating the option is now changed
7. Disconnect the battery from the receiver
8. Turn the transmitter off



## To Change CH5 to X-port or X-port to CH5

When X-Port is active, CH5 and CH6 are not available; however, reversed aileron (CH2) is still available.

1. Ensure the receiver and transmitter are bound
2. Plug the X-Port accessory or the optional servo into the X-Port/CH5 port
3. Turn the transmitter on
4. Move the THRO stick to the full throttle position
5. Move the control sticks to the corresponding position to change between the available options (see illustration)
6. Hold this position and plug the battery into the receiver
7. The LED on the receiver will turn solid within 5 seconds and the LED will flash 3 times quickly, indicating the option is now changed
8. Disconnect the battery from the receiver
9. Turn the transmitter off

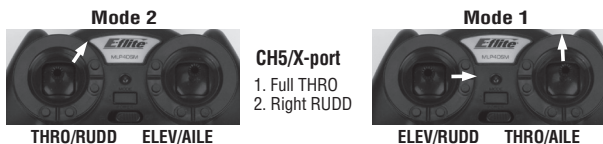

## Optional Support Items

Please see [www.horizonhobby.com](http://www.horizonhobby.com) for a complete list of items.

## Programming the Brushless ESC

To access a programmable feature, power on with full throttle (musical confirmation sound).

### Brake

- Pull throttle to center (1 long beep).
  - To assign **No Brake**: Push throttle to full (1 short beep). **(Default)**  
Pull back to center throttle to confirm setting (Hi Lo Hi Lo sound).
  - To assign **Soft Brake**: Keep throttle at full for 5 seconds (2 short beeps).  
Pull back to center throttle to confirm setting (Hi Lo Hi Lo sound).
  - To assign **Center Brake**: Keep throttle at full for 10 seconds (3 short beeps).  
Pull back to center throttle to confirm setting (Hi Lo Hi Lo sound).
  - To assign **Hard Brake**: Keep throttle at full for 15 seconds (4 short beeps).  
Pull back to center throttle to confirm setting (Hi Lo Hi Lo sound).

### Timing

- Pull throttle to center, hold for 5 seconds (2 long beeps).
  - 5°**: Push throttle to full (1 short beep).  
Pull back to center throttle to confirm setting (Hi Lo Hi Lo sound).
  - 10°**: Keep throttle at full for 5 seconds (2 short beeps).  
Pull back to center throttle to confirm setting (Hi Lo Hi Lo sound).
  - 15°**: Keep throttle at full for 10 seconds (3 short beeps). **(Default)**  
Pull back to center throttle to confirm setting (Hi Lo Hi Lo sound).
  - 20°**: Keep throttle at full for 15 seconds (4 short beeps).  
Pull back to center throttle to confirm setting (Hi Lo Hi Lo sound).
  - 25°**: Keep throttle at full for 20 seconds (5 short beeps).  
Pull back to center throttle to confirm setting (Hi Lo Hi Lo sound).

### Throttle Range

- Pull throttle to center, hold for 10 seconds (3 long beeps).
  - 1.2–1.8ms**: Push throttle to full (1 short beep). **(Default)**  
Pull back to center throttle to confirm setting (Hi Lo Hi Lo sound)
  - 1.1–1.9ms**: Keep throttle at full for 5 seconds (2 short beeps).  
Pull back to center throttle to confirm setting (Hi Lo Hi Lo sound).

### Starting Rate

- Pull throttle to center, hold for 15 seconds (4 long beeps).
  - 0.25s**: Push throttle to full (1 short beep). **(Default)**  
Pull back to center throttle to confirm setting (Hi Lo Hi Lo sound).
  - 1.0s**: Keep throttle at full for 5 seconds (2 short beeps).  
Pull back to center throttle to confirm setting (Hi Lo Hi Lo sound).

### PWM Switching Frequency

- Pull throttle to center, hold for 20 seconds (5 long beeps).
  - 8kHz**: Push throttle to full (1 short beep). **(Default)**  
Pull back to center throttle to confirm setting (Hi Lo Hi Lo sound).
  - 16kHz**: Keep throttle at full for 5 seconds (2 short beeps).  
Pull back to center throttle to confirm setting (Hi Lo Hi Lo sound).
  - 32kHz**: Keep throttle at full for 10 seconds (3 short beeps).  
Pull back to center throttle to confirm setting (Hi Lo Hi Lo sound).

### Mode

- Pull throttle to center, hold for 25 seconds (6 long beeps).
  - Normal Mode**: Push throttle to full (1 short beep). **(Default)**  
Pull back to center throttle to confirm setting (Hi Lo Hi Lo sound).
  - Heli Mode**: Keep throttle at full for 5 seconds (2 short beeps).  
Pull back to center throttle to confirm setting (Hi Lo Hi Lo sound).

Cutoff voltage: 6.1V is unchangeable.

Recycle ESC power with throttle idle after changing settings.

Recycle the power after you hear the Hi Lo Hi Lo confirming beeps after changing the settings.



## 2.4GHz Troubleshooting Guide

| Problem                                                                              | Possible Cause                                                                                                                        | Solution                                                                                                                                          |
|--------------------------------------------------------------------------------------|---------------------------------------------------------------------------------------------------------------------------------------|---------------------------------------------------------------------------------------------------------------------------------------------------|
| Aircraft will not “throttle up” but all other controls seem to function              | User did not lower throttle trim and throttle stick prior to initializing the aircraft                                                | Lower throttle stick and throttle trim to their lowest settings                                                                                   |
|                                                                                      | Throttle channel is reversed.<br>Futaba transmitters (equipped with Spektrum modules) may require you to reverse the throttle channel | Reverse throttle channel on specific transmitter if applicable                                                                                    |
| LED on aircraft remains flashing and cannot be controlled by transmitter             | User did not wait at least 5 seconds after powering the transmitter prior to connecting the flight battery to the aircraft            | Unplug, then reconnect flight battery                                                                                                             |
|                                                                                      | User bound the aircraft to a different transmitter                                                                                    | Rebind aircraft to your desired compatible transmitter                                                                                            |
|                                                                                      | Transmitter was too close to aircraft during the initialization process                                                               | Move transmitter (powered on) a few feet from the aircraft prior to reconnecting the flight battery                                               |
| Controls appear to be reversed after binding to a different transmitter              | User did not initially set up transmitter prior to binding to the aircraft                                                            | See the “Advanced Programming” section of this manual                                                                                             |
| Aircraft does not function after connecting flight battery and aircraft smells burnt | User may have accidentally plugged the flight battery in with the wrong polarity                                                      | Replace AR6400NBL board and ensure the RED polarity marks are facing the same direction when connecting the flight battery to the AR6400NBL board |

| Problem                                    | Possible Cause                                                                                 | Solution                                                                                                                                                                                             |
|--------------------------------------------|------------------------------------------------------------------------------------------------|------------------------------------------------------------------------------------------------------------------------------------------------------------------------------------------------------|
| The system will not connect                | Your transmitter and receiver are too close together. They should be 8 to 12 feet apart        | Move transmitter 8 to 12 feet from receiver                                                                                                                                                          |
|                                            | You are around metal objects                                                                   | Move to an area with less metal                                                                                                                                                                      |
|                                            | Model selected is not the model bound to                                                       | Check model selected and ensure you are bound to that model                                                                                                                                          |
|                                            | Your transmitter was accidentally put into bind mode and is not bound to your receiver anymore | Rebind your transmitter and receiver                                                                                                                                                                 |
| Receiver quits responding during operation | Inadequate battery voltage                                                                     | Charge batteries. Spektrum receivers require at least 3.5V to operate. An inadequate power supply can allow voltage to momentarily drop below 3.5V and cause the receiver to brown out and reconnect |
|                                            | Loose or damaged wires or connectors between battery and receiver                              | Check the wires and connection between battery and receiver. Repair or replace wires and/or connectors                                                                                               |
| Receiver loses its bind                    | Transmitter stand or tray could be depressing the bind button                                  | If stand is depressing bind button, remove from stand and rebind                                                                                                                                     |
|                                            | Bind button pressed before transmitter turned on                                               | Rebind your system following binding instructions                                                                                                                                                    |
| Receiver blinking at landing               | System turned on and connected then receiver turned off without turning off transmitter        | Turn off transmitter when receiver is turned off                                                                                                                                                     |

# 1-Year Limited Warranty

---

## What this Warranty Covers

Horizon Hobby, Inc., (Horizon) warrants to the original purchaser that the product purchased (the "Product") will be free from defects in materials and workmanship for a period of 1 years from the date of purchase.

## What is Not Covered

This warranty is not transferable and does not cover (i) cosmetic damage, (ii) damage due to acts of God, accident, misuse, abuse, negligence, commercial use, or due to improper use, installation, operation or maintenance, (iii) modification of or to any part of the Product, (iv) attempted service by anyone other than a Horizon Hobby authorized service center, or (v) Products not purchased from an authorized Horizon dealer.

OTHER THAN THE EXPRESS WARRANTY ABOVE, HORIZON MAKES NO OTHER WARRANTY OR REPRESENTATION, AND HEREBY DISCLAIMS ANY AND ALL IMPLIED WARRANTIES, INCLUDING, WITHOUT LIMITATION, THE IMPLIED WARRANTIES OF NON-INFRINGEMENT, MERCHANTABILITY AND FITNESS FOR A PARTICULAR PURPOSE. THE PURCHASER ACKNOWLEDGES THAT THEY ALONE HAVE DETERMINED THAT THE PRODUCT WILL SUITABLY MEET THE REQUIREMENTS OF THE PURCHASER'S INTENDED USE.

## Purchaser's Remedy

Horizon's sole obligation and purchaser's sole and exclusive remedy shall be that Horizon will, at its option, either (i) service, or (ii) replace, any Product determined by Horizon to be defective. Horizon reserves the right to inspect any and all Product(s) involved in a warranty claim. Service or replacement decisions are at the sole discretion of Horizon. Proof of purchase is required for all warranty claims. SERVICE OR REPLACEMENT AS PROVIDED UNDER THIS WARRANTY IS THE PURCHASER'S SOLE AND EXCLUSIVE REMEDY.

## Limitation of Liability

HORIZON SHALL NOT BE LIABLE FOR SPECIAL, INDIRECT, INCIDENTAL OR CONSEQUENTIAL DAMAGES, LOSS OF PROFITS OR PRODUCTION OR COMMERCIAL LOSS IN ANY WAY, REGARDLESS OF WHETHER SUCH CLAIM IS BASED IN CONTRACT, WARRANTY, TORT, NEGLIGENCE, STRICT LIABILITY OR ANY OTHER THEORY OF LIABILITY, EVEN IF HORIZON HAS BEEN ADVISED OF THE POSSIBILITY OF SUCH DAMAGES. Further, in no event shall the liability of Horizon exceed the individual price of the Product on which liability is asserted. As Horizon has no control over use, setup, final assembly, modification or misuse, no liability shall be assumed nor accepted for any resulting damage or injury. By the act of use, setup or assembly, the user accepts all resulting liability. If you as the purchaser or user are not prepared to accept the liability associated with the use of the Product, purchaser is advised to return the Product immediately in new and unused condition to the place of purchase.

## Law

These terms are governed by Illinois law (without regard to conflict of law principals). This warranty gives you specific legal rights, and you may also have other rights which vary from state to state. Horizon reserves the right to change or modify this warranty at any time without notice.

## WARRANTY SERVICES

### Questions, Assistance, and Services

Your local hobby store and/or place of purchase cannot provide warranty support or service. Once assembly, setup or use of the Product has been started, you must contact your local distributor or Horizon directly. This will enable Horizon to better answer your questions and service you in the event that you may need any assistance. For questions or assistance, please direct your email to [productsupport@horizonhobby.com](mailto:productsupport@horizonhobby.com), or call 877.504.0233 toll free to speak to a Product Support representative. You may also find information on our website at [www.horizonhobby.com](http://www.horizonhobby.com).

### Inspection or Services

If this Product needs to be inspected or serviced, please use the Horizon Online Service Request submission process found on our website or call Horizon to obtain a Return Merchandise Authorization (RMA) number. Pack the Product securely using a shipping carton. Please note that original boxes may be included, but are not designed to withstand the rigors of shipping without additional protection. Ship via a carrier that provides tracking and insurance for lost or damaged parcels, as Horizon is not responsible for merchandise until it arrives and is accepted at our facility. An Online Service Request is available at <http://www.horizonhobby.com> under the Support tab. If you do not have internet access, please contact Horizon Product Support to obtain a RMA number along with instructions for submitting your product for service. When calling Horizon, you will be asked to provide your complete name, street address, email address and phone number where you can be reached during business hours. When sending product into Horizon, please include your RMA number, a list of the included items, and a brief summary of the problem. A copy of your original sales receipt must be included for warranty consideration. Be sure your name, address, and RMA number are clearly written on the outside of the shipping carton.

**Notice: Do not ship LiPo batteries to Horizon. If you have any issue with a LiPo battery, please contact the appropriate Horizon Product Support office.**

### Warranty Requirements

**For Warranty consideration, you must include your original sales receipt verifying the proof-of-purchase date.** Provided warranty conditions have been met, your Product will be serviced or replaced free of charge. Service or replacement decisions are at the sole discretion of Horizon.

### Non-Warranty Service

**Should your service not be covered by warranty service will be completed and payment will be required without notification or estimate of the expense unless the expense exceeds 50% of the retail purchase cost.** By submitting the item for service you are agreeing to payment of the service without notification. Service estimates are available upon request. You must include this request with your item submitted for service. Non-warranty service estimates will be billed a minimum of ½ hour of labor. In addition you will be billed for return freight. Horizon accepts money orders and cashiers checks, as well as Visa, MasterCard, American Express, and Discover cards. By submitting any item to Horizon for service, you are agreeing to Horizon's Terms and Conditions found on our website <http://www.horizonhobby.com/Service/Request/>.

## Warranty and Service Contact Information

| Country of Purchase      | Horizon Hobby                                    | Address                                                                            | Phone Number/Email Address                                                                                                     |
|--------------------------|--------------------------------------------------|------------------------------------------------------------------------------------|--------------------------------------------------------------------------------------------------------------------------------|
| United States of America | Horizon Service Center (Electronics and engines) | 4105 Fieldstone Rd<br>Champaign, Illinois<br>61822 USA                             | 877-504-0233<br>Online Repair Request:<br>visit <a href="http://www.horizonhobby.com/service">www.horizonhobby.com/service</a> |
|                          | Horizon Product Support (All other products)     | 4105 Fieldstone Rd<br>Champaign, Illinois<br>61822 USA                             | 877-504-0233<br><a href="mailto:productsupport@horizonhobby.com">productsupport@horizonhobby.com</a>                           |
| United Kingdom           | Horizon Hobby Limited                            | Units 1-4 Ployters Rd<br>Staple Tye<br>Harlow, Essex<br>CM18 7NS<br>United Kingdom | +44 (0) 1279 641 097<br><a href="mailto:sales@horizonhobby.co.uk">sales@horizonhobby.co.uk</a>                                 |
| Germany                  | Horizon Technischer Service                      | Christian-Junge-Straße 1<br>25337 Elmshorn<br>Germany                              | +49 (0) 4121 2655 100<br><a href="mailto:service@horizonhobby.de">service@horizonhobby.de</a>                                  |
| France                   | Horizon Hobby SAS                                | 14 Rue Gustave Eiffel<br>Zone d'Activité du Réveil Matin<br>91230 Montgeron        | +33 (0) 1 60 47 44 70<br><a href="mailto:infofrance@horizonhobby.com">infofrance@horizonhobby.com</a>                          |

## Customer Service Information

| Country of Purchase      | Horizon Hobby         | Address                                                                            | Phone Number/Email Address                           |
|--------------------------|-----------------------|------------------------------------------------------------------------------------|------------------------------------------------------|
| United States of America | Sales                 | 4105 Fieldstone Rd<br>Champaign, Illinois<br>61822 USA                             | (800) 338-4639<br>sales@horizonhobby.com             |
| United Kingdom           | Horizon Hobby Limited | Units 1-4 Ployters Rd<br>Staple Tye<br>Harlow, Essex<br>CM18 7NS<br>United Kingdom | +44 (0) 1279 641 097<br>sales@horizonhobby.co.uk     |
| Germany                  | Horizon Hobby GmbH    | Christian-Junge-Straße 1<br>25337 Elmshorn<br>Germany                              | +49 4121 46199 60<br>service@horizonhobby.de         |
| France                   | Horizon Hobby SAS     | 14 Rue Gustave Eiffel<br>Zone d'Activité du Réveil Matin<br>91230 Montgeron        | +33 (0) 1 60 47 44 70<br>infofrance@horizonhobby.com |

## FCC Information

This device complies with part 15 of the FCC rules. Operation is subject to the following two conditions: (1) This device may not cause harmful interference, and (2) this device must accept any interference received, including interference that may cause undesired operation.

**CAUTION:** Changes or modifications not expressly approved by the party responsible for compliance could void the user's authority to operate the equipment.

This product contains a radio transmitter with wireless technology which has been tested and found to be compliant with the applicable regulations governing a radio transmitter in the 2.400GHz to 2.4835GHz frequency range.

# Compliance Information for the European Union Declaration of Conformity

(in accordance with ISO/IEC 17050-1)

No. HH20110926



Product(s): AR6400NBL DSM2 6Ch Ultra Micro RX  
Item Number(s): SPMAR6400NBL  
Equipment class: 1

The objects of declaration described above are in conformity with the requirements of the specifications listed below, following the provisions of the European R&TTE directive 1999/5/EC:

**EN 301 489-1 V1.7.1: 2006**

**EN 301 489-17 V1.3.2: 2008**

Signed for and on behalf of:

Horizon Hobby, Inc.  
Champaign, IL USA  
September 26, 2011

Vice President  
International Operations and Risk Management  
Horizon Hobby, Inc.

## Instructions for disposal of WEEE by users in the European Union



This product must not be disposed of with other waste. Instead, it is the user's responsibility to dispose of their waste equipment by handing it over to a designated collections point for the recycling of waste electrical and electronic equipment. The separate collection and recycling of your waste equipment at the time of disposal will help to conserve natural resources and ensure that it is recycled in a manner that protects human health and the environment. For more information about where you can drop off your waste equipment for recycling, please contact your local city office, your household waste disposal service or where you purchased the product.



# SPEKTRUM®

© 2011 Horizon Hobby, Inc.

X-Port, DSM2, E-flite, JR, Smart Bind and ParkZone are trademarks or registered trademarks of Horizon Hobby, Inc.

The Spektrum trademark is used with permission of Bachmann Industries, Inc.

Sbach and its design are trademarks of STO Streicher GmbH & Co. KG registered in Germany and used with permission.

Sbach and its design are trademarks of XtremeAir GmbH registered in the U.S. and used with permission.

US 7,898,130. US D578,146. PRC ZL 200720069025.2. Other patents pending.

Created 9/11 33569