



PROBOAT™
ProBoatModels.com

Impulse™ 31

31-INCH BRUSHLESS RTR DEEP-V

PRB08008

**Owners Manual • Bedienungsanleitung
Manuel de l'utilisateur • Manuale dell'utente**

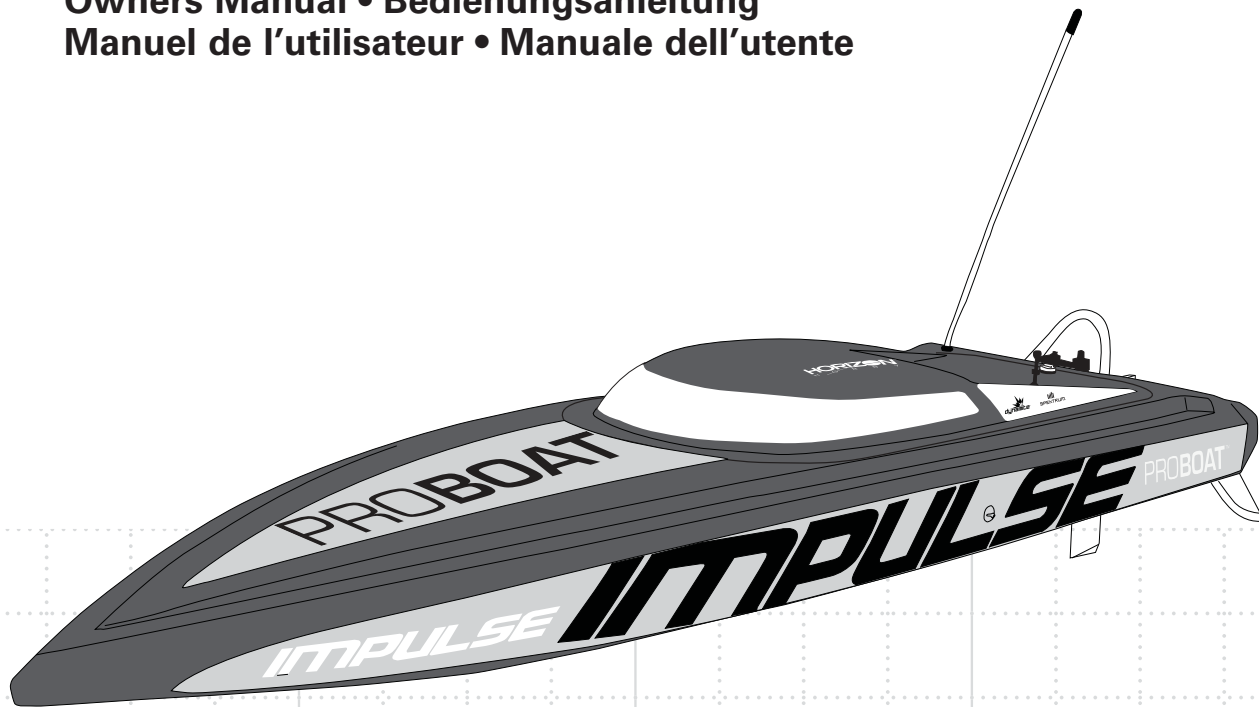

NOTICE

All instructions, warranties and other collateral documents are subject to change at the sole discretion of Horizon Hobby, LLC. For up-to-date product literature, visit <http://www.horizonhobby.com> and click on the support tab for this product.

Meaning of Special Language

The following terms are used throughout the product literature to indicate various levels of potential harm when operating this product:

NOTICE: Procedures, which if not properly followed, create a possibility of physical property damage AND little or no possibility of injury.

CAUTION: Procedures, which if not properly followed, create the probability of physical property damage AND a possibility of serious injury.

WARNING: Procedures, which if not properly followed, create the probability of property damage, collateral damage, and serious injury OR create a high probability of superficial injury.



WARNING: Read the ENTIRE instruction manual to become familiar with the features of the product before operating. Failure to operate the product correctly can result in damage to the product, personal property and cause serious injury.

This is a sophisticated hobby product and NOT a toy. It must be operated with caution and common sense and requires some basic mechanical ability. Failure to operate this Product in a safe and responsible manner could result in injury or damage to the product or other property. This product is not intended for use by children without direct adult supervision. Do not use with incompatible components or alter this product in any way outside of the instructions provided by Horizon Hobby, LLC. This manual contains instructions for safety, operation and maintenance. It is essential to read and follow all the instructions and warnings in the manual, prior to assembly, setup or use, in order to operate correctly and avoid damage or serious injury.

WARNING AGAINST COUNTERFEIT PRODUCTS

Thank you for purchasing a genuine Spektrum product. Always purchase from an authorized Horizon Hobby dealer to ensure authentic high-quality Spektrum product. Horizon Hobby, LLC disclaims all support and warranty with regards, but not limited to, compatibility and performance of counterfeit products or products claiming compatibility with DSM or Spektrum.

Age Recommendation: Not for children under 14 years. This is not a toy.

Safety Precautions and Warnings

As the user of this product, you are solely responsible for operating in a manner that does not endanger yourself and others or result in damage to the product or the property of others.

- When handling and/or transporting your boat, always pick up the boat from the front, keeping all moving parts pointed away from you.
- Always keep a safe distance in all directions around your model to avoid collisions or injury. This model is controlled by a radio signal subject to interference from many sources outside your control. Interference can cause momentary loss of control.
- Always operate your model in open spaces away from full-size vehicles, traffic and people.
- Always carefully follow the directions and warnings for this and any optional support equipment (chargers, rechargeable battery packs, etc.).
- Always keep all chemicals, small parts and anything electrical out of the reach of children.
- Always avoid water exposure to all equipment not specifically designed and protected for this purpose. Moisture causes damage to unprotected electronics.
- Never place any portion of the model in your mouth as it could cause serious injury or even death.
- Never operate your model with low transmitter batteries.

Water-Resistant Boat with Waterproof Electronics

Your new Horizon Hobby boat has been designed and built with a combination of waterproof and water-resistant components to allow you to operate the product in calm, fresh water conditions.

While the entire boat is highly water-resistant, it is not completely waterproof and your boat should NOT be treated like a submarine. The various electronic components used in the boat, such as the Electronic Speed Control (ESC), servo(s) and receiver are waterproof, however, most of the mechanical components are water-resistant and require additional maintenance after use.

Metal parts, including the bearings, pins, screws and nuts, propeller, rudder, rudder mounts, prop struts, as well as the contacts in the electrical cables, will be susceptible to corrosion if additional maintenance is not performed after running in wet conditions. To maximize the long-term performance of your boat and to keep the warranty intact, the procedures described in the "Wet Conditions Maintenance" section must be performed regularly.



CAUTION: Failure to exercise caution while using this product and complying with the following precautions could result in product malfunction and/or void the warranty.

General Precautions

- Read the **WET CONDITIONS MAINTENANCE** procedures and make sure that you have all the tools you will need to properly maintain your boat.
- Not all batteries can be used in wet conditions. Consult the battery manufacturer before use. Caution should be taken when using Li-Po batteries in wet conditions.
- Most transmitters are not water-resistant. Consult your transmitter's manual or the manufacturer before operation.
- Never operate your transmitter or boat when lightning is present.
- Salt water is very conductive and highly corrosive. If you choose to run your boat in salt water, immediately rinse the boat in fresh water after each use. Operating your boat in salt water is at the sole discretion of the modeler.
- Even minimal water contact can reduce the life of your motor if it has not been certified as water-resistant or waterproof. If the motor becomes excessively wet, apply very light throttle until the water is mostly removed from the motor. Running a wet motor at high speeds may rapidly damage the motor.
- Driving in wet conditions can reduce the life of the motor. The additional resistance of operating in water causes excess strain.

Wet Conditions Maintenance

- Drain any water that has collected in the hull by removing the drain plug or canopy and tilting the boat in the appropriate direction to drain the water.

CAUTION: Always keep hands, fingers, tools and any loose or hanging objects away from rotating parts.

- Remove the battery pack(s) and disconnect the ESC and motor. Dry the contacts. If you have an air compressor or a can of compressed air, blow out any water that may be inside the recessed connector housings.
- Remove the flex shaft and all moving parts. Dry and lubricate parts after every 30 minutes of operation or if the boat becomes submerged.

NOTICE: Never use a pressure washer to clean your boat.

- Use an air compressor or a can of compressed air to dry the boat and help remove any water that may have gotten into small crevices or corners.
- Spray the bearings, fasteners and other metal parts with a water-displacing light oil or lubricant. Do not spray the motor.
- Let the boat air dry before you store it. Water (and oil) may continue to drip for a few hours.

Specifications

Length	31 in (787mm)
Beam (width)	9 in (229mm)
Hull Material	Fiberglass Composite
Motor	Dynamite® 1750Kv, 4-pole
ESC	Dynamite 120-amp brushless, water-cooled
Transmitter	Spektrum™ DX2E 2.4GHz Pistol Grip
Receiver	Spektrum SR310
Batteries	4 AA batteries (sold separately) are required to operate the transmitter: (2) Reaction 7.4V 5000mAh 2S 50C LiPo Hardcase with EC5: DYNB3810EC, or (2) Reaction 11.1V 5000mAh 50C LiPo Hardcase with EC5: DYNB3811EC.

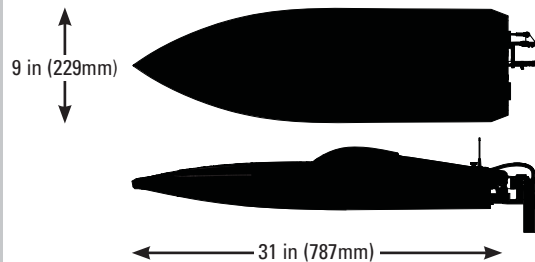

Register your boat online at www.proboatmodels.com.

Table of Contents

Water-Resistant Boat with Waterproof Electronics	2
General Precautions	3
Wet Conditions Maintenance	3
Specifications.....	3
Recommended Tools and Materials	4
Boat Stand Assembly.....	4
Antenna Tube Installation.....	4
Canopy Removal	5
Battery Charger	5
Low Voltage Cutoff (LVC).....	5
Installing the Battery Packs	5
Spektrum DX2E Radio System.....	6
Installing the Transmitter Batteries	6
Binding	7
Getting Started	7
Range Check	8
Testing Your Boat in the Water.....	8
Boating Tips	9
Motor Care	9
When You Are Finished	9

Product Inspection

Carefully remove the boat and radio transmitter from the box. Inspect the boat for damage. If your product is damaged, please contact the hobby shop where you purchased your boat.

After Boating and Maintenance.....	10
Water Cooling System.....	10
Prop Angle Adjustment	11
Drivetrain Lubrication	11
Troubleshooting Guide	12
Limited Warranty	13
Warranty and Service Contact Information.....	14
FCC Information	15
IC Information	15
Compliance Information for the European Union.....	15
Instructions for Disposal of WEEE	15
Replacement Parts	58
Optional Parts	58

Recommended Tools and Materials

- Needle nose pliers
- Paper towel
- Rubbing alcohol
- Open-end wrench: 10mm (2)
- Nut driver: 4mm, 5.5mm, 8mm
- Phillips screwdriver: #1
- Hex wrench: 1.5mm, 2mm, 2.5mm, 3mm
- Clear tape (DYNAM0102)
- Pro Boat® Marine Grease and Gun
- Hook and Loop Tape Set, WP 4pcs

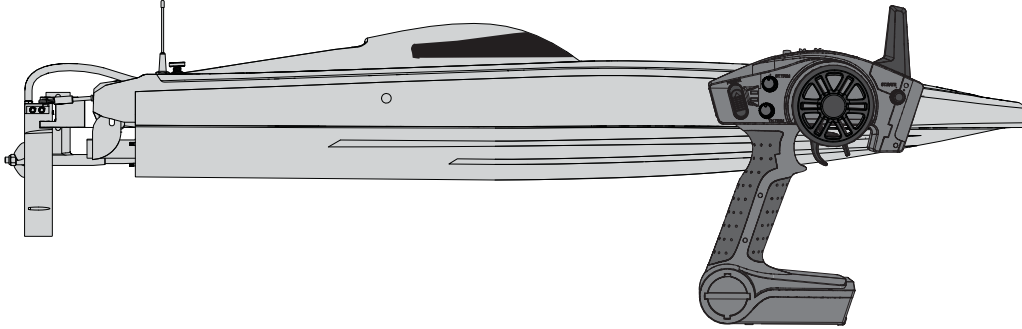

Boat Stand Assembly

1. Attach the side stand pieces to the end pieces as shown.
2. Use medium CA or epoxy adhesive to secure the side stand to the ends.
3. Allow the adhesive to dry before placing your boat on the stand.

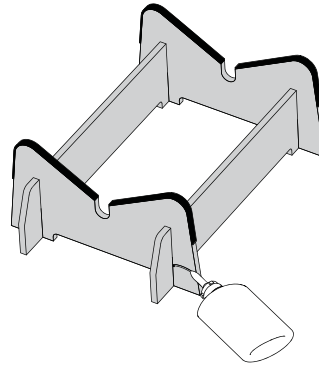

Antenna Tube Installation

1. Carefully feed the end of the receiver antenna through the grommet inside the hull.
2. Pull the antenna wire out of the grommet towards the outside of the boat, then slide the antenna through the antenna tube.
3. Insert the tube into the grommet, then fit the cap onto the tube.
4. Apply clear tape to the antenna, grommet and hull in the boat to keep the antenna from moving.

The antenna must be installed above the boat's waterline to get the best reception of your transmitter's signal.

NOTICE: Do not cut or kink the receiver antenna or damage may result.

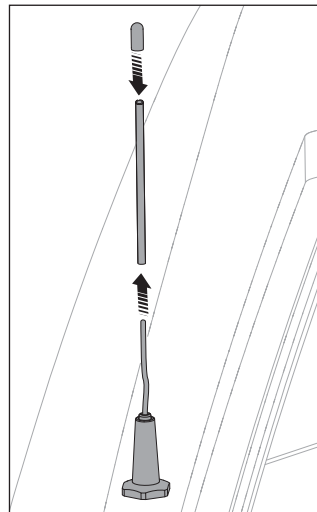

Canopy Removal

1. Push down and turn the latch button one quarter of a turn to disengage the pin from the hull.
2. Carefully lift the rear of the canopy and pull back to disengage the front pin from the hull.

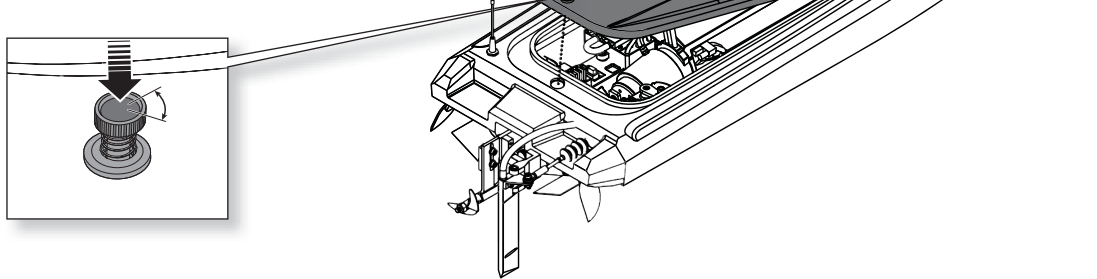

Battery Charger

Choose a charger designed to charge the recommended Dynamite® Reaction® 11.1V 5700mAh 3S 80C Li-Po battery. We recommend either the Dynamite Prophet™ Sport Plus 50W AC/DC Charger or the Dynamite Prophet Sport Duo 2 X 50W charger. Refer to your charger manual for charging instructions and safety information.

NOTICE: Never charge a battery in the boat or damage may result.

Low Voltage Cutoff (LVC)

The included ESC protects the boat battery from over-discharge using Low Voltage Cutoff (LVC). Before the battery charge decreases too much, LVC removes power supplied to the motor, and the boat slows noticeably.

Disconnect and remove the Li-Po battery from the boat after use to prevent trickle discharge. Charge your Li-Po battery to about half capacity before storage. LVC does not prevent the battery from over-discharge during storage.

NOTICE: Applying the throttle after the LVC will over discharge the battery and cause battery damage.

Tip: Monitor your boat battery's voltage before and after boating by using a Li-Po Cell Voltage Checker (DYN4071, sold separately).

Installing the Battery Packs

1. Install the 2 battery packs opposite each other in the compartment. Secure with the hook and loop straps. If running your boat in rougher water conditions, the use of Waterproof Hook and Loop Tape (DYNK0300) may also be needed to fully secure your batteries' positions.

Tip: Move the packs forward or back to adjust the center of gravity for your boat. The center of gravity is roughly one-third of the overall length of the boat. Move the packs toward the bow so the bow rides lower in the water. Move the packs away from the bow so that the bow rides higher in the water.

2. Connect each battery pack to the ESC power connectors.

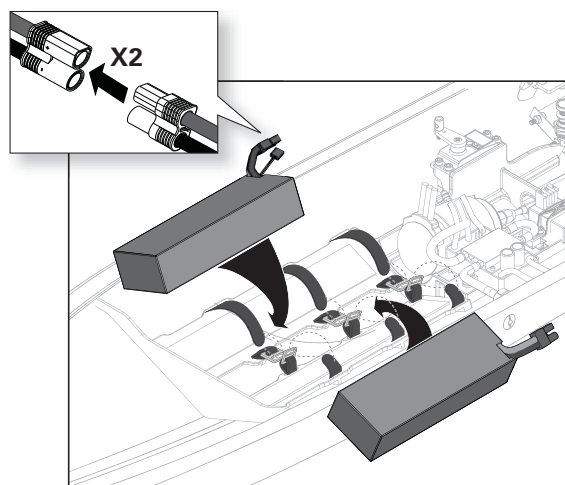

Spektrum DX2E Radio System

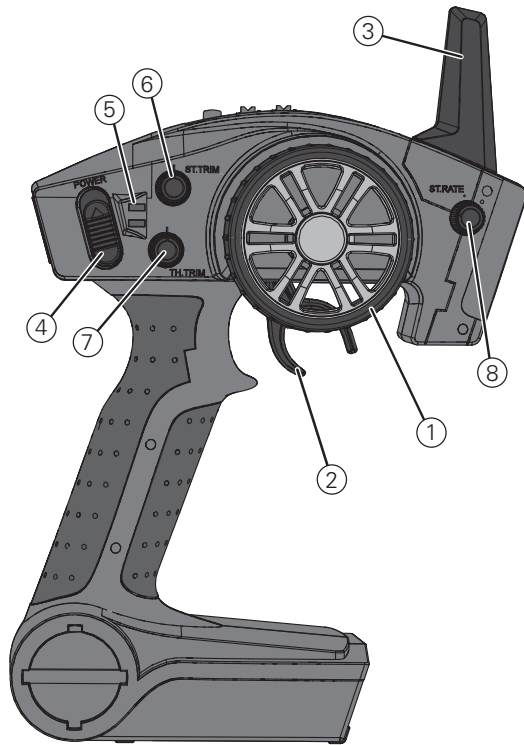

For more information on the transmitter, go to www.spektrumrc.com and click on the support tab to find the full manual for the DX2E transmitter.

1. **Steering Wheel** controls direction (left/right) of the model.
2. **Throttle Trigger** controls speed.
3. **Antenna** transmits the signal to the model.
4. **ON/OFF Switch** turns the power ON/OFF for the transmitter.
5. **Indicator Lights**
 - Solid green light indicates adequate battery power.
 - Flashing green light indicates the battery voltage is critically low. Replace batteries.
6. **ST. Trim** adjusts the “hands off” direction of the model.
7. **TH. Trim** adjusts the motor speed to idle at neutral.
8. **Steering Dual Rate** adjusts the amount the rudder moves when the steering wheel is turned left and right.
9. **BIND Button** puts the transmitter into Bind Mode.
10. **ST. REV** reverses the function of the steering when the wheel is turned left or right.
11. **TH. REV** reverses the function of the speed control when pulled back or pushed forward.

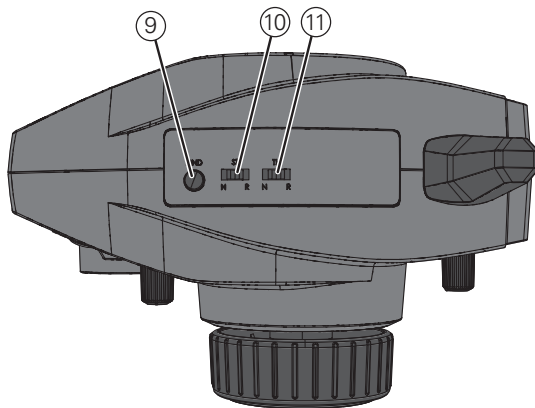

Installing the Transmitter Batteries

1. Push in the battery cover a small amount to release the retaining tab, then remove the cover.
2. Install 4 AA batteries, taking care to align battery polarity to the diagram in the transmitter's battery case.
3. Carefully reinstall the battery cover by aligning the tabs with the slots on the transmitter.

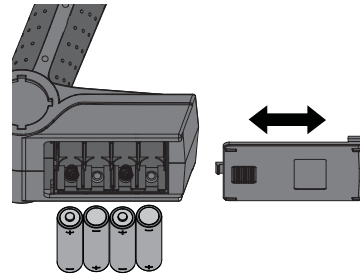

CAUTION: NEVER remove the transmitter batteries while the vehicle is powered on, as loss of control, property damage or injury may result.

IMPORTANT: Remove the transmitter batteries after use.



CAUTION: If using rechargeable batteries, charge only rechargeable batteries. Charging non-rechargeable batteries may cause the batteries to burst, resulting in injury to persons and/or damage to property.

Binding

Binding is the process of programming the receiver to recognize the GUID (Globally Unique Identifier) code of a single specific transmitter. The included transmitter and receiver are bound at the factory. If you need to rebind, follow the instructions below.

1. Ensure the transmitter and vehicle are both powered OFF.
2. Install the bind plug in the BIND/battery port of the receiver. Power the receiver through any other port.
3. Power ON the vehicle. The receiver LED will blink green.
4. Stand approximately 8–12 feet (2.4–3.7m) from the vehicle. With the steering wheel and throttle trigger in the failsafe positions (neutral), press and hold the bind button and power ON the transmitter. The transmitter's green LED will blink after 3 seconds, indicating it is in bind mode.
5. Release the bind button when the green LED flashes. Continue holding failsafe positions until the binding process is complete.
6. The receiver LED will glow solid when the transmitter and receiver are bound.
7. Power OFF the vehicle, then the transmitter.
8. Remove the bind plug and store it in a convenient place.

The receiver will keep the binding to the transmitter until another binding is done.

If you encounter problems, obey binding instructions and refer to the troubleshooting guide for other instructions. If needed, contact the appropriate Horizon Product Support office.

NOTICE: Do not attempt to bind the transmitter and receiver if there are other compatible transmitters in bind mode within 400 feet. Doing so may result in unexpected binding.

Failsafe

In the unlikely event that the radio connection is lost during use, the receiver will drive the servos to their pre-programmed failsafe positions (normally no throttle and straight steering).

If the receiver is powered on before powering on the transmitter, the receiver will enter this failsafe mode. When the transmitter is powered on, normal control is resumed.

IMPORTANT: Failsafe activates only in the event that signal is lost from the transmitter. Failsafe will NOT activate in the event that receiver battery power decreases below the recommended minimums or power to the receiver is lost.

Getting Started

1. Power on the transmitter.
2. Connect the two batteries to the EC5™ connectors on the ESC.
3. Power on the ESC.
4. Test the transmitter's control of the boat with the boat on the display stand.

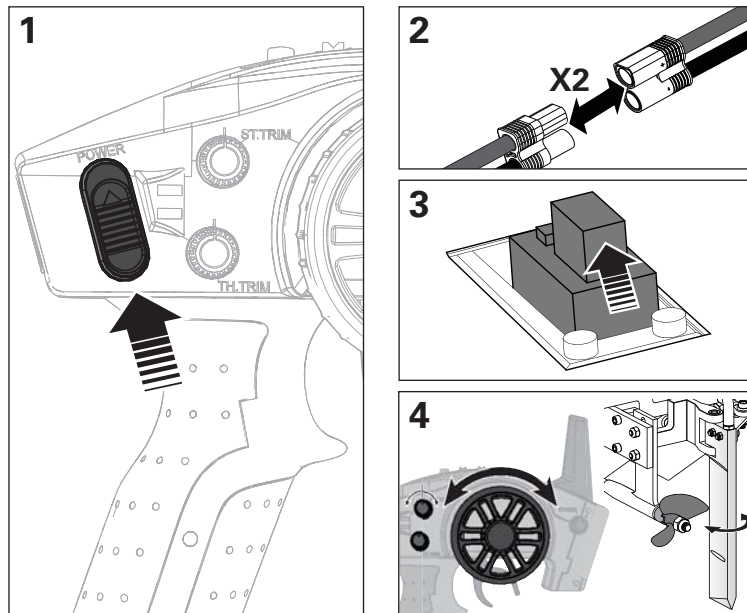

Range Check

IMPORTANT: Perform a range check at the beginning of each boating session, after repair or after installation of new batteries.

Ensure the receiver antenna is extended properly and all batteries are fully charged.

1. With the radio system powered on and connected, walk away from your boat 90 feet (32 m).
2. Have an assistant remain with the boat to check for proper control movement of the rudder in response to your transmitter input.
3. If everything appears to be operating correctly, prepare to operate the boat in the water.

NOTICE: Do not operate the motor without water cooling circulation or damage may result.

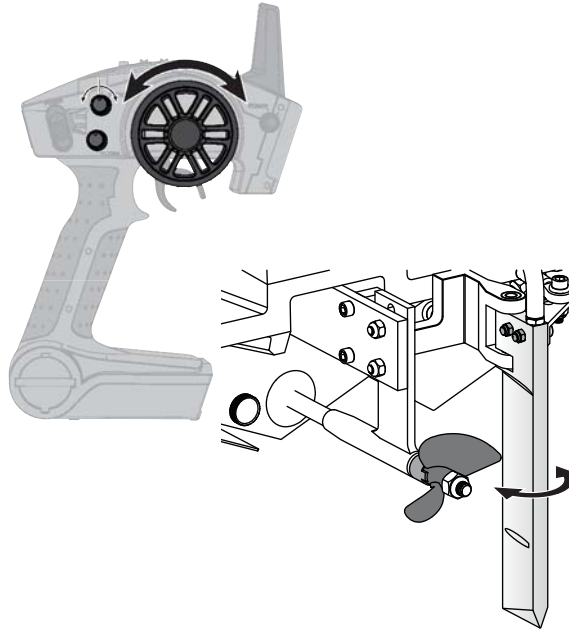

Testing Your Boat in the Water

Tip: Before placing your boat in the water, secure the canopy on the hull. Apply clear tape (DYNM0102), if desired.

1. Carefully place the boat in the water.
2. Operate the boat at slow speeds near the shoreline. Avoid objects in the water at all times. When the boat is moving forward, ensure water flows out of the coolant outlet. Remove any blockage from the rudder inlet and coolant system or the motor and ESC (electronic speed control) may overheat.
3. Once you are comfortable operating the boat at slow speeds, it is safe to operate the boat farther from the shore.
4. If the boat does not go straight, adjust the steering trim dial on the transmitter.

Tip: If you are using too much steering trim on your transmitter to make the boat drive straight, return the trim to neutral and mechanically center the rudder. To do this, loosen the ball link from the rudder horn, then turn the ball link on the linkage threads until the rudder is properly centered.

5. Bring the boat back to shore when you notice the boat starting to lose speed.
6. Power off the ESC and disconnect the battery packs.
7. Allow the motor, ESC and battery packs to cool before charging the batteries or operating the boat again.

NOTICE: Do not turn off the transmitter first or the receiver may pick up stray signals and run out of control.

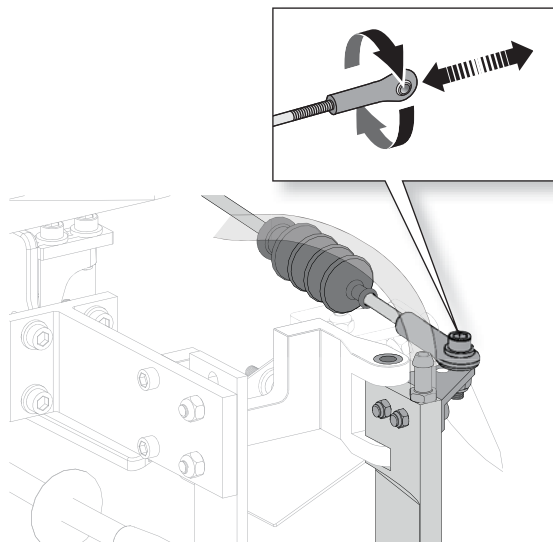

Boating Tips

When running your boat for the first time, we recommend calm wind and water conditions so that you can learn how the boat responds to your control.

Maximum speeds are only achieved when the water conditions are smooth and there is little wind. A sharp turn, wind or waves can turn over a boat when it is moving quickly. Always pilot your boat for the wind and water conditions so that the boat does not turn over.

Consult local laws and ordinances before choosing a location to pilot your boat.

Avoid boating near:

- watercraft
- people (swimming areas, fishing areas)
- stationary objects
- waves, wakes
- rapidly moving water
- wildlife
- floating debris
- overhanging trees
- vegetation

If the propeller and rudder are blocked with debris or vegetation, remove the boat from the water and remove the debris before continuing operation.

When making turns, decrease the throttle to reduce the probability of flipping the boat over.

Never operate your boat in less than 12 inches (30.5 cm) of water.

If you need to retrieve your boat from the water, use fishing equipment or another boat.

NOTICE: When running at full speed in choppy waters, the prop may exit and re-enter the water repeatedly and very quickly, subjecting the propeller and flex shaft to some stress. Frequent stress may damage the propeller and flex shaft.



CAUTION: Never operate your boat in extreme temperatures or turbulent water.



CAUTION: Never attempt to retrieve a downed boat by swimming.

NOTICE: Crash damage is not covered under warranty.

Motor Care

- Prolong motor life by preventing overheating conditions. Undue motor wear results from frequent turns, stops and starts, pushing objects, boating in rough water or vegetation and boating continuously at high speed.
- Over-temperature protection is installed on the ESC to prevent circuit damage, but cannot protect the motor from pushing against heavy resistance.

When You Are Finished

1. Power off the ESC.
2. Power off the transmitter.
3. Disconnect and remove the batteries from the boat.

Tip: Always remove the canopy before storage or moisture may allow mold and mildew to grow in the boat.

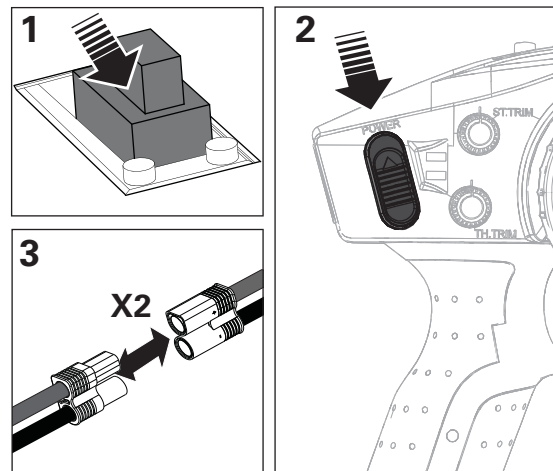

After Boating and Maintenance

- Drain water from inside the hull using the drain plug
- Fully dry the inside and outside of the boat, including the water cooling lines and jacket around the motor. Remove the hatch before storing your boat
- Repair any damage or wear to the boat
- Lubricate the flex shaft using Pro Boat Marine Grease (PRB0100)
- Make note of lessons learned from the trimming of your boat, including water and wind conditions

Tip: The hook and loop strips in the boat retain water. To dry them, press on them with a dry cloth.

NOTICE: When you are finished boating, never leave the boat in direct sunlight or in a hot, enclosed area such as a car. Doing so can damage the boat.

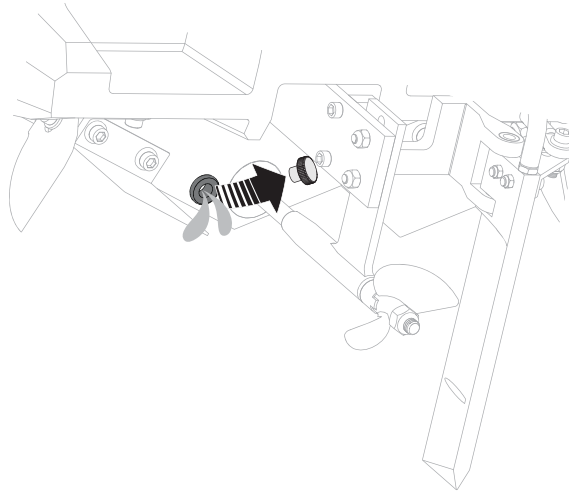

Water Cooling System

If water does not stream out of the water outlets while the boat is moving forward, immediately stop the boat and clean the obstruction from the water cooling system.

1. Disassemble and clean the water cooling system to remove blockage and prevent overheating.
2. Replace damaged parts.

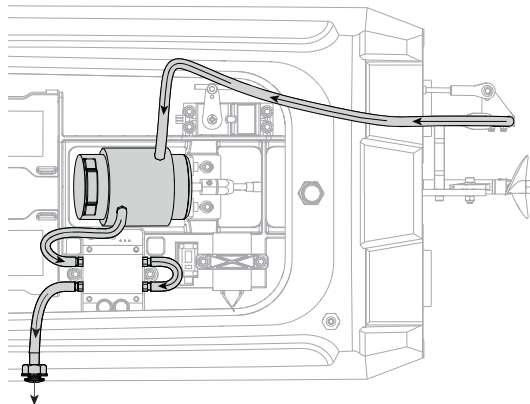

Prop Angle Adjustment

Raising the prop strut increases speed, but also decreases steering response and increases cavitation.

Lowering the drive strut increases steering response, but also increases steering sensitivity and decreases speed.

1. Loosen 2 bolts and 2 nuts from the drive strut on the rear of the boat.
2. Slide the strut up or down to change the angle of the propeller in relation to the hull.

Tip: For ideal performance, adjust the strut to achieve 2-2.5 degrees of positive angle.

3. Adjust as desired and tighten the nuts and bolts.

Tip: Battery location, trim tab angle, turn fin angle and prop angle may be adjusted to change how the boat rides in the water.

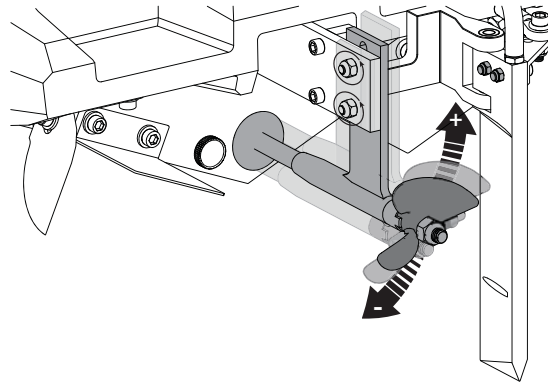

Drivetrain Lubrication

Always replace the drivetrain parts when they are damaged or show visible wear or injury and damage may result.

Lubricating the flex shaft is vital to the life of the drivetrain. The lubricant also acts as a water seal, keeping water from entering the hull through the stuffing tube.

Lubricate the flex shaft, drive strut, and all moving parts after every 30 minutes of operation.

1. In the hull, use 2 10mm open-end wrenches to loosen the collet nut from the flex shaft.
2. Slide the flex shaft out from the stuffing tube and drive strut at the rear of the boat.

Tip: Use paper or cloth to touch the flex shaft and other lubricated parts.

3. Wipe the old lubricant and material from the flex shaft.
4. Lubricate the full length of the flex shaft assembly up to the drive dog using marine grease (PRB0101 or PRB0100). Also apply grease to the collet threads.
5. Carefully reinstall the flex shaft in the drive strut, stuffing tube and collet. If the flex shaft is difficult to remove or install in the collet, use a flat screwdriver to spread the grips of the collet.

Ensure there is a 2-3mm gap between the drive strut and drive dog to allow for flex shaft shrinkage under load.

NOTICE: Running the boat in saltwater could cause some parts to corrode. If you run the boat in saltwater, rinse it thoroughly in freshwater after each use and lubricate the drive system.

NOTICE: Because of its corrosive effects, running RC boats in saltwater is at the discretion of the modeler.

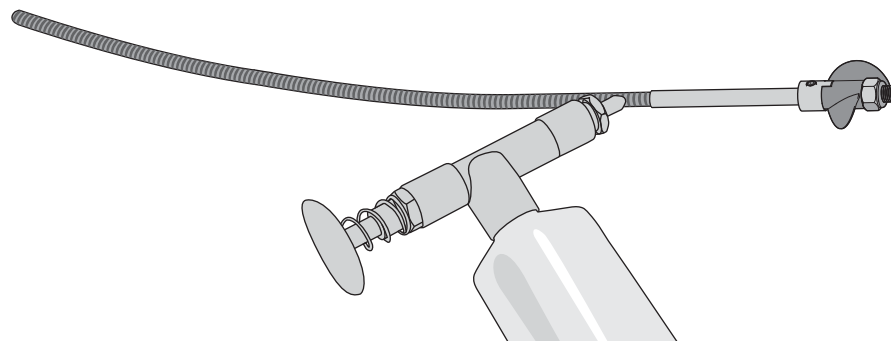
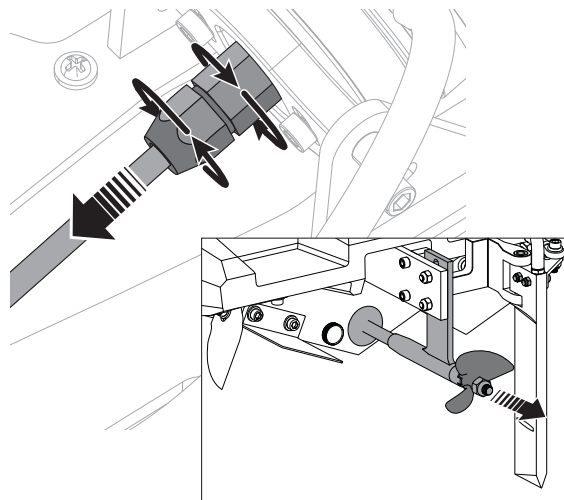



Troubleshooting Guide

Problem	Possible Cause	Solution
Boat will not respond to throttle but responds to other controls	Throttle channel is reversed	Reverse throttle channel on transmitter
Extra noise or extra vibration	Damaged propeller, shaft or motor	Replace damaged parts
	Propeller is out of balance	Balance or replace propeller
Reduced runtime or boat underpowered	Boat battery charge is low	Completely recharge battery
	Boat battery is damaged	Replace boat battery and follow battery instructions
	Blocking or friction on shaft or propeller	Disassemble, lubricate and correctly align parts
	Boat conditions may be too cold	Make sure the battery is warm (above 10° C [50° F]) before use
	Battery capacity may be too low for conditions	Replace battery or use a larger capacity battery
	Drive dog is too near the prop strut	Loosen motor coupling on flex shaft and move flex shaft a small amount
	Too little lubrication on flex shaft	Fully lubricate flex shaft
Boat will not Bind (during binding) to transmitter	Vegetation or other obstacles block the rudder or propeller	Remove vegetation or obstacles from rudder or propeller
	Transmitter is too near boat during binding process	Move powered transmitter a few feet from boat, disconnect and reconnect battery to boat
	Boat or transmitter is too close to large metal object, wireless source or another transmitter	Move the boat and transmitter to another location and attempt binding again
	Another compatible transmitter is powered on within range of the receiver	Power off all compatible transmitters except the one you are trying to bind
	Boat battery/Transmitter battery charge is too low	Replace/recharge batteries
Boat will not connect (after binding) to transmitter	ESC switch is off	Power on ESC switch
	Transmitter is too near boat during connecting process	Move powered transmitter a few feet from boat, disconnect and reconnect battery to boat
	Boat or transmitter is too close to large metal object, wireless source or another transmitter	Move boat or transmitter to another location and attempt to connect again
	Boat battery/transmitter battery charge is too low	Replace/recharge batteries
Boat tends to dive in the water or takes on water	ESC switch is off	Power on ESC switch
	The boat hull is not completely closed	Dry out the boat and ensure the hatch is fully closed on the hull before returning the boat to the water
	Center of gravity is too far forward	Move batteries back in the hull
Boat tends to turn one direction	Trim tabs are angled incorrectly	Angle each trim tab up a small amount to lift the bow or down a small amount to lower the bow
	Rudder or rudder trim is not centered	Repair rudder or adjust rudder and rudder trim for straight running when control is at neutral
	Incorrect turn fin angle	Adjust fin angle, with tip above drive strut center line

Problem	Possible Cause	Solution
Rudder does not move	Rudder, linkage or servo damage	Replace or repair damaged parts and adjust controls
	Steering servo wire is damaged or connections are loose	Do a check of steering servo wires and connections, connect or replace as needed
	Transmitter is not bound correctly	Re-bind
	BEC (Battery Elimination Circuit) of the ESC is damaged	Replace ESC
	ESC switch is off	Power on ESC switch
Rear of boat shakes	Incorrect turn fin angle	Raise tip of turn fins above drive strut center line
Controls reversed	Transmitter settings are reversed	Do the Control Direction Test and adjust controls on transmitter appropriately
Motor overheats	Blocked water cooler tubes	Clean or replace water tubes
Motor power pulses then motor loses power	ESC uses default soft Low Voltage Cutoff (LVC)	Recharge boat battery or replace battery that is no longer performing
	Weather conditions might be too cold	Postpone until weather is warmer
	Battery is old, worn out or damaged	Replace battery

LIMITED WARRANTY

What this Warranty Covers

Horizon Hobby, LLC (Horizon) warrants to the original purchaser that the product purchased (the "Product") will be free from defects in materials and workmanship at the date of purchase.

What is Not Covered

This warranty is not transferable and does not cover (i) cosmetic damage, (ii) damage due to acts of God, accident, misuse, abuse, negligence, commercial use, or due to improper use, installation, operation or maintenance, (iii) modification of or to any part of the Product, (iv) attempted service by anyone other than a Horizon Hobby authorized service center, (v) Product not purchased from an authorized Horizon dealer, or (vi) Product not compliant with applicable technical regulations.

OTHER THAN THE EXPRESS WARRANTY ABOVE, HORIZON MAKES NO OTHER WARRANTY OR REPRESENTATION, AND HEREBY DISCLAIMS ANY AND ALL IMPLIED WARRANTIES, INCLUDING, WITHOUT LIMITATION, THE IMPLIED WARRANTIES OF NON-INFRINGEMENT, MERCHANTABILITY AND FITNESS FOR A PARTICULAR PURPOSE. THE PURCHASER ACKNOWLEDGES THAT THEY ALONE HAVE DETERMINED THAT THE PRODUCT WILL SUITABLY MEET THE REQUIREMENTS OF THE PURCHASER'S INTENDED USE.

Purchaser's Remedy

Horizon's sole obligation and purchaser's sole and exclusive remedy shall be that Horizon will, at its option, either (i) service, or (ii) replace, any Product determined by Horizon to be defective. Horizon reserves the right to inspect any and all Product(s) involved in a warranty claim. Service or replacement decisions are at the sole discretion of Horizon. Proof of purchase is required for all warranty claims. SERVICE OR REPLACEMENT AS PROVIDED UNDER THIS WARRANTY IS THE PURCHASER'S SOLE AND EXCLUSIVE REMEDY.

Limitation of Liability

HORIZON SHALL NOT BE LIABLE FOR SPECIAL, INDIRECT, INCIDENTAL OR CONSEQUENTIAL DAMAGES, LOSS OF PROFITS OR PRODUCTION OR COMMERCIAL LOSS IN ANY WAY, REGARDLESS OF WHETHER SUCH CLAIM IS BASED IN CONTRACT, WARRANTY, TORT, NEGLIGENCE, STRICT LIABILITY OR ANY OTHER THEORY OF LIABILITY, EVEN IF HORIZON HAS BEEN ADVISED OF THE POSSIBILITY OF SUCH DAMAGES. Further, in no event shall the liability of Horizon exceed the individual price of the Product on which liability is asserted. As Horizon has no control over use, setup, final assembly, modification or misuse, no liability shall be assumed nor accepted for any resulting damage or injury. By the act of use, setup or assembly, the user accepts all resulting liability. If you as the purchaser or user are not prepared to accept the liability associated with the use of the Product, purchaser is advised to return the Product immediately in new and unused condition to the place of purchase.

Law

These terms are governed by Illinois law (without regard to conflict of law principals). This warranty gives you specific legal rights, and you may also have other rights which vary from state to state. Horizon reserves the right to change or modify this warranty at any time without notice.

WARRANTY SERVICES

Questions, Assistance, and Services

Your local hobby store and/or place of purchase cannot provide warranty support or service. Once assembly, setup or use of the Product has been started, you must contact your local distributor or Horizon directly. This will enable Horizon to better answer your questions and service you in the event that you may need any assistance. For questions or assistance, please visit our website at www.horizonhobby.com, submit a Product Support Inquiry, or call the toll free telephone number referenced in the Warranty and Service Contact Information section to speak with a Product Support representative.

Inspection or Services

If this Product needs to be inspected or serviced and is compliant in the country you live and use the Product in, please use the Horizon Online Service Request submission process found on our website or call Horizon to obtain a Return Merchandise Authorization (RMA) number. Pack the Product securely using a shipping carton. Please note that original boxes may be included, but are not designed to withstand the rigors of shipping without additional protection. Ship via a carrier that provides tracking and insurance for lost or damaged parcels, as Horizon is not responsible for merchandise until it arrives and is accepted at our facility. An Online Service Request is available at http://www.horizonhobby.com/content/_service-center_render-service-center. If you do not have internet access, please contact Horizon Product Support to obtain a RMA number along with instructions for submitting your product for service. When calling Horizon, you will be asked to provide your complete name, street address, email address and phone number where you can be reached during business hours. When sending product into Horizon, please include your RMA number, a list of the included items, and a brief summary of the problem. A copy of your original sales receipt must be included for warranty consideration. Be sure your name, address, and RMA number are clearly written on the outside of the shipping carton.

NOTICE: Do not ship LiPo batteries to Horizon. If you have any issue with a LiPo battery, please contact the appropriate Horizon Product Support office.

Warranty Requirements

For Warranty consideration, you must include your original sales receipt verifying the proof-of-purchase date. Provided warranty conditions have been met, your Product will be serviced or replaced free of charge. Service or replacement decisions are at the sole discretion of Horizon.

Non-Warranty Service

Should your service not be covered by warranty, service will be completed and payment will be required without notification or estimate of the expense unless the expense exceeds 50% of the retail purchase cost. By submitting the item for service you are agreeing to payment of the service without notification. Service estimates are available upon request. You must include this request with your item submitted for service. Non-warranty service estimates will be billed a minimum of ½ hour of labor. In addition you will be billed for return freight. Horizon accepts money orders and cashier's checks, as well as Visa, MasterCard, American Express, and Discover cards. By submitting any item to Horizon for service, you are agreeing to Horizon's Terms and Conditions found on our website http://www.horizonhobby.com/content/_service-center_render-service-center.

⚠ ATTENTION: Horizon service is limited to Product compliant in the country of use and ownership. If received, a non-compliant Product will not be serviced. Further, the sender will be responsible for arranging return shipment of the un-serviced Product, through a carrier of the sender's choice and at the sender's expense. Horizon will hold non-compliant Product for a period of 60 days from notification, after which it will be discarded.

WARRANTY AND SERVICE CONTACT INFORMATION

Country of Purchase	Horizon Hobby	Contact Information	Address
United States of America	Horizon Service Center (Repairs and Repair Requests)	servicecenter.horizonhobby.com/RequestForm/	4105 Fieldstone Rd Champaign, Illinois, 61822 USA
	Horizon Product Support (Product Technical Assistance)	www.quickbase.com/db/bghj7ey8c?a=GenNewRecord	
	Sales	888-959-2306	
United Kingdom	Service/Parts/Sales: Horizon Hobby Limited	sales@horizonhobby.com +44 (0) 1279 641 097	Units 1-4 , Ployters Rd, Staple Tye Harlow, Essex, CM18 7NS, United Kingdom
Germany	Horizon Technischer Service	service@horizonhobby.de	Christian-Junge-Straße 1 25337 Elmshorn, Germany
	Sales: Horizon Hobby GmbH	+49 (0) 4121 2655 100	
France	Service/Parts/Sales: Horizon Hobby SAS	infofrance@horizonhobby.com +33 (0) 1 60 18 34 90	11 Rue Georges Charpak 77127 Lieusaint, France
China	Service/Parts/Sales: Horizon Hobby – China	info@horizonhobby.com.cn +86 (021) 5180 9868	Room 506, No. 97 Changshou Rd. Shanghai, China 200060

FCC Information

This device complies with part 15 of the FCC rules. Operation is subject to the following two conditions:

- (1) This device may not cause harmful interference, and
- (2) This device must accept any interference received, including interference that may cause undesired operation.

CAUTION: Changes or modifications not expressly approved by the party responsible for compliance could void the user's authority to operate the equipment.

This product contains a radio transmitter with wireless technology which has been tested and found to be compliant with the applicable regulations governing a radio transmitter in the 2.400GHz to 2.4835GHz frequency range.

Antenna Separation Distance

When operating your Spektrum transmitter, please be sure to maintain a separation distance of at least 5 cm between your body (excluding fingers, hands, wrists, ankles and feet) and the antenna to meet RF exposure safety requirements as determined by FCC regulations.

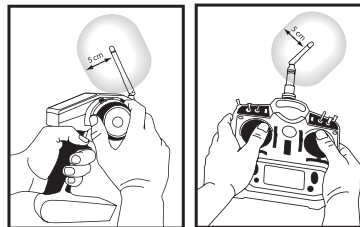

The following illustrations show the approximate 5 cm RF exposure area and typical hand placement when operating your Spektrum transmitter.

IC Information

This device complies with Industry Canada licence-exempt RSS standard(s). Operation is subject to the following two conditions: (1) this device may not cause interference, and (2) this device must accept any interference that may cause undesired operation of the device.

COMPLIANCE INFORMATION FOR THE EUROPEAN UNION

Declaration of Conformity

(in accordance with ISO/IEC 17050-1)

No. HH2015012903

Product(s): Pro Boat Impulse 31 Deep-V V3
BL: RTR

Item Number(s): PRB08008I
Equipment class: 1

The object of declaration described above is in conformity with the requirements of the specifications listed below, following the provisions of the European R&TTE directive 1999/5/EC, EMC Directive 2004/108/EC and LVD Directive 2006/95/EC:

EN 300-328 V1.8.1

EN 301 489-1 V1.9.2: 2012

EN 301 489-17 V2.1.1: 2009

EN 60950-1:2006+A11:2009+A1:2010+A12: 2011+A2: 2013

EN 62311: 2008

EN 55022:2010 + AC:2011

EN 55024:2010



Signed for and on behalf of:
Horizon Hobby, LLC
Champaign, IL USA
January 29, 2015

Mike Dunne
Executive Vice President Product Divisions,
Horizon Hobby, LLC



Instructions for disposal of WEEE by users in the European Union

This product must not be disposed of with other waste. Instead, it is the user's responsibility to dispose of their waste equipment by handing it over to a designated collections point for the recycling of waste electrical and electronic equipment. The separate collection and recycling of your waste equipment at the time of disposal will help to conserve natural resources and ensure that it is recycled in a manner that protects human health and the environment. For more information about where you can drop off your waste equipment for recycling, please contact your local city office, your household waste disposal service or where you purchased the product.