

RTR
READY-TO-RUN



EIGHTTM

1/8-SCALE HIGH-PERFORMANCE
4WD GAS TRUGGY



INSTRUCTION MANUAL
BEDIENUNGSANLEITUNG
MANUEL D'UTILISATION

Before operating this vehicle, please read all printed materials thoroughly.
Horizon Hobby is not responsible for inadvertent errors in this manual.

NOTICE

All instructions, warranties and other collateral documents are subject to change at the sole discretion of Horizon Hobby, LLC. For up-to-date product literature, visit horizonhobby.com and click on the support tab for this product.

Meaning of Special Language

The following terms are used throughout the product literature to indicate various levels of potential harm when operating this product:

NOTICE: Procedures, which if not properly followed, create a possibility of physical property damage AND a little or no possibility of injury.

CAUTION: Procedures, which if not properly followed, create the probability of physical property damage AND a possibility of serious injury.

WARNING: Procedures, which if not properly followed, create the probability of property damage, collateral damage, and serious injury OR create a high probability of superficial injury.

 **WARNING:** Read the ENTIRE instruction manual to become familiar with the features of the product before operating. Failure to operate the product correctly can result in damage to the product, personal property and cause serious injury.

This is a sophisticated hobby product. It must be operated with caution and common sense and requires some basic mechanical ability. Failure to operate this Product in a safe and responsible manner could result in injury or damage to the product or other property. This product is not intended for use by children without direct adult supervision. Do not attempt disassembly, use with incompatible components or alter this product in any way outside the instructions provided by Horizon Hobby, LLC. This manual contains instructions for safety, operation and maintenance. It is essential to read and follow all the instructions and warnings in the manual, prior to assembly, setup or use, in order to operate correctly and avoid damage or serious injury.

AGE RECOMMENDATION: NOT FOR CHILDREN UNDER 14 YEARS. THIS IS NOT A TOY.

Register your Losi Product Online

Register your vehicle now and be the first to find out about the latest option parts, product updates and more. Click on the Support tab at WWW.LOSI.COM and follow the product registration link to stay connected.

General Safety Precautions and Guidelines

This model is controlled by a radio signal subject to interference from many sources outside your control. This interference may cause momentary loss of control, so it is advisable to always keep some distance in all directions around your model as a safety margin to avoid collisions.

- Always ensure all screws and nuts are tightened.
- Always carefully follow the directions and warnings for this and any optional support equipment.
- Always keep all chemicals, small parts and anything electrical out of the reach of children.
- Always ensure the failsafe is properly set during binding.
- Always operate your model in an open area away from cars, traffic and people.
- When operating this vehicle, always keep it at least 20 feet from spectators, especially small children.
- Never run your vehicle through deep water that will submerge the vehicle.
- Never run your model in a public street where damage can occur.
- Never run your model with low transmitter batteries.
- When finished operating, always power off the engine first, then the receiver, then the transmitter.
- Always perform maintenance on the vehicle after each and every use. Due to engine vibration, all screws and nuts will need to be checked to ensure they are tight.

Li-Po Charger Safety Precautions and Warnings

- **Never leave the charger and battery unattended during use.**
- **Never charge batteries overnight.**
- Never attempt to charge dead, damaged or wet battery packs.
- Never attempt to charge a battery pack containing different types of batteries.
- Never allow minors to charge battery packs.
- Never charge batteries in extremely hot or cold places or place in direct sunlight.
- Never charge a battery if the cable has been pinched or shorted.
- Never connect more than one battery pack to this charger at a time.
- Never connect the charger if the power cable has been pinched or shorted.
- Never attempt to dismantle the charger or use a damaged charger.
- Never reverse the positive and negative terminals.
- Always use only rechargeable batteries designed for use with this type of charger.
- Always inspect the battery before charging.
- Always keep the battery away from any material that could be affected by heat.
- Always monitor the charging area and have a fire extinguisher available at all times.
- Always end the charging process if the battery becomes hot to the touch or starts to change form (swell) during the charge process.
- Always disconnect the battery after charging, and let the charger cool between charges.
- Always terminate all processes and contact Horizon Hobby if the product malfunctions.



WARNING: Never leave the charger unattended, exceed maximum charge rate, charge with non-approved batteries or charge batteries in the wrong mode. Failure to comply may result in excessive heat, fire and serious injury.



CAUTION: Always ensure the battery you are charging meets the specifications of this charger and that the charger settings are correct. Not doing so can result in excessive heat and other related product malfunctions, which can lead to user injury or property damage. Please contact Horizon Hobby or an authorized retailer with compatibility questions.

Water-resistant Vehicle with Waterproof Electronics

Your new Horizon Hobby vehicle has been designed and built with a combination of waterproof and water-resistant components to allow you to operate the product in many “wet conditions”, including puddles, creeks, wet grass, snow and even rain.

While the entire vehicle is highly water-resistant, it is not completely waterproof and your vehicle should NOT be treated like a submarine. The various electronic components used in the vehicle, such as the servo(s) and receiver are waterproof, however, most of the mechanical components are water-resistant and should not be submerged.

Metal parts, including the bearings, hinge pins, screws and nuts, as well as the contacts in the electrical cables, will be susceptible to corrosion if additional maintenance is not performed after running in wet conditions. To maximize the long-term performance of your vehicle and to keep the warranty intact, the procedures described in the “Wet Conditions Maintenance” section below must be performed regularly if you choose to run in wet conditions. If you are not willing to perform the additional care and maintenance required, then you should not operate the vehicle in those conditions.

CAUTION: Failure to exercise caution while using this product and complying with the following precautions could result in product malfunction and/or void the warranty.

GENERAL PRECAUTIONS

- Read through the wet conditions maintenance procedures and make sure that you have all the tools you will need to properly maintain your vehicle.
- Not all batteries can be used in wet conditions. Consult the battery manufacturer before use. Caution should be taken when using Li-Po batteries in wet conditions.
- Most transmitters are not water-resistant. Consult your transmitter’s manual or the manufacturer before operation.
- Never operate your transmitter or vehicle where lightning may be present.
- Do not operate your vehicle where it could come in contact with salt water (ocean water or water on salt-covered roads), contaminated or polluted water. Salt water is very conductive and highly corrosive, so use caution.
- While the air filter assembly can be designed to limit or restrict water ingestion into the engine, no air filter is completely waterproof. If too much water is ingested into the engine, severe damage to the engine may result.
- Do not expose your engine to rapid changes in temperature. These engines tend to operate at temperatures between 200–265°F (93–129°C) in normal operating conditions. If the engine is exposed to cold water while operating at this temperature, there is a risk of “thermal shock”, which could cause undue stress on the engine and a shortened engine lifespan.
- Driving in wet conditions can reduce the life of the engine. The additional resistance of operating in water causes excess strain. Alter the gear ratio by using a smaller pinion or larger spur gear. This will reduce the load on the engine (and engine temperatures) when running in mud, deeper puddles, or any wet conditions that will increase stress on the engine for an extended period of time.

Wet Conditions Maintenance

- Remove the battery pack(s) and dry the contacts. If you have an air compressor or a can of compressed air, blow out any water that may be inside the recessed connector housing.
- Remove the tires/wheels from the vehicle and gently rinse the mud and dirt off with a garden hose. Avoid rinsing the bearings and transmission.

NOTICE: Never use a pressure washer to clean your vehicle.

- Use an air compressor or a can of compressed air to dry the vehicle and help remove any water that may have gotten into small crevices or corners.
- Spray the bearings, drive train, fasteners and other metal parts with a water-displacing light oil or lubricant.

- Let the vehicle air dry before you store it. Water (and oil) may continue to drip for a few hours.
- Increase the frequency of disassembly, inspection and lubrication of the following:
 - Front and rear axle hub assembly bearings.
 - All transmission cases, gears and differentials.
 - Engine air filter element.
 - Engine clutch assembly, including shoes and bearings.

Components

- 1/8-Scale High Performance Gasoline Truggy
- Spektrum™ DX2E 2.4GHz DSM® Radio System
- Dynamite® .31 ci Gasoline Engine
- Spektrum High-Torque Servos
- 4 AA batteries (for transmitter)
- Spektrum 7.4V 1300mAh Li-Po receiver pack
- Losi Starter Box

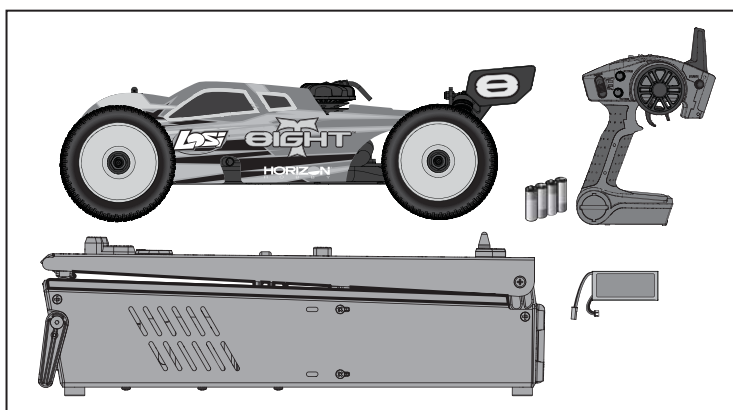

Tools Included

- Wheel wrench
- Four (4) Hex “L” Wrench Set: .050-inch, 1/16-inch, 5/64-inch and 3/32-inch
- Shock Bottom wrench
- Turnbuckle/Shock Top wrench
- Spark Plug Wrench (DYNT1250)

Needed to Complete

- 91 Octane Gasoline
- Gasoline Approved Dispenser
- 2 x 6 cell NIMH Battery (DYN1050)
- Small flat blade and Phillips screwdrivers (DYNT2100 and DYN3048)
- Needle-nose pliers
- Quality .050-inch, 1/16-inch, 5/64-inch, 3/32-inch, 1.5mm and 2.5mm hex (Allen) drivers (DYN2950)

Use only Dynamite tools or other high-quality tools. Use of inexpensive tools can cause damage to the small screws and parts used on this type of model.

Charging the Receiver Battery Pack

Spektrum 7.4V 1300mAh Li-Po receiver pack

The Spektrum 2S Li-Po battery pack (SPMB1300LPRX) features a balancing lead that allows you to safely charge your battery pack when used with a Li-Po balancing charger.

1. Remove the LiPo receiver battery pack from the battery box and disconnect the red JST connector.
2. Connect the LiPo battery charger to an AC power outlet.
3. Refer to manufacturers battery charging directions.

Installing the Receiver Battery in the Battery Box

1. Connect the fully charged LiPo battery pack to the red JST connector in the battery box.
2. Place the battery box cover on the battery box.

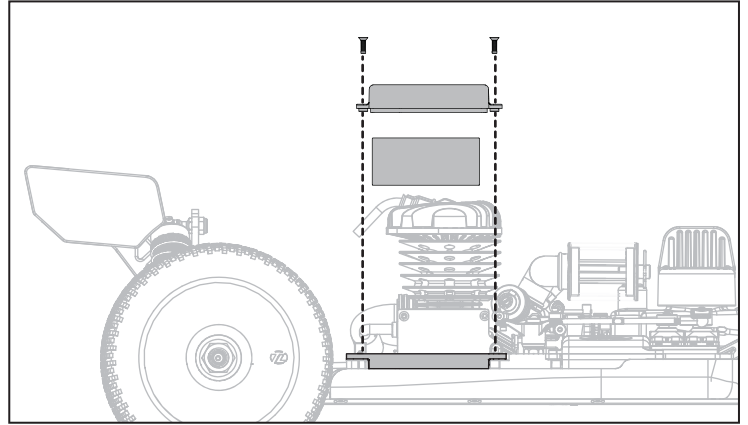

Spektrum DX2E Radio System

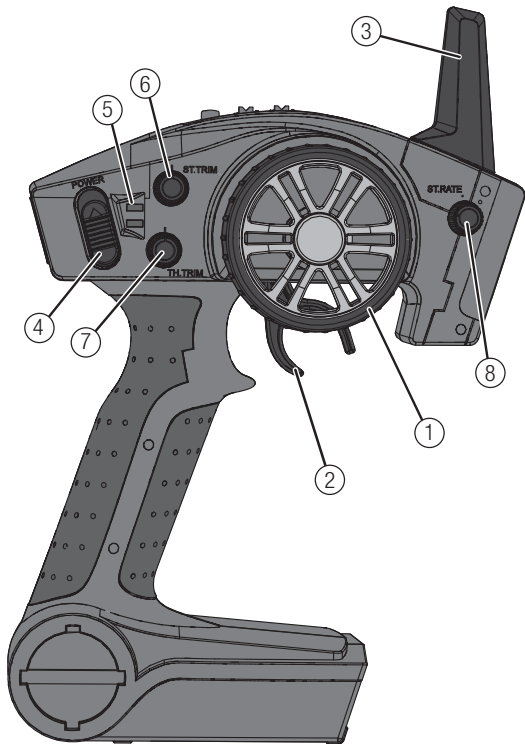

For more information on the transmitter, go to www.spektrumrc.com and click on the support tab to find the full manual for the DX2E transmitter.

1. **Steering Wheel** controls direction (left/right) of the model.
2. **Throttle Trigger** controls speed.
3. **Antenna** transmits the signal to the model.
4. **ON/OFF Switch** turns the power ON/OFF for the transmitter.
5. **Indicator Lights**
 - Solid green light indicates adequate battery power.
 - Flashing green light indicates the battery voltage is critically low. Replace batteries.
6. **ST. Trim** adjusts the "hands off" direction of the model.
7. **TH. Trim** adjusts the engine speed to idle at neutral.
8. **ST. Rate** Adjusts the AVC sensitivity.
9. **BIND/R.O.S.S.** button puts the transmitter into Bind Mode and starts or stops the engine using R.O.S.S. (the 8IGHT-T RTR does NOT use ROSS).
10. **ST. REV** reverses the function of the steering when the wheel is turned left or right.
11. **TH. REV** reverses the throttle control when pulled back or pushed forward.

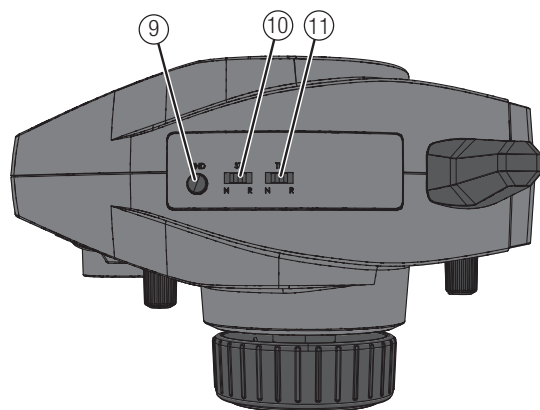

Installing the Transmitter Batteries

1. Push in the battery cover a small amount to release the retaining tab, then remove the cover.
2. Install 4 AA batteries, taking care to align battery polarity to the diagram in the transmitter's battery case.
3. Carefully reinstall the battery cover by aligning the tabs with the slots on the transmitter.

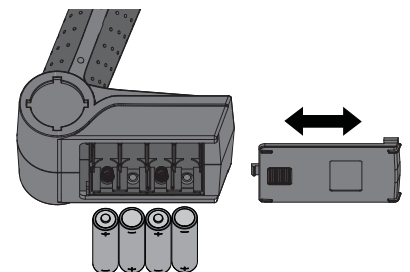

CAUTION: If using rechargeable batteries, charge only rechargeable batteries. Charging non-rechargeable batteries may cause the batteries to burst, resulting in injury to persons and/or damage to property.



CAUTION: NEVER remove the transmitter batteries while the vehicle is powered on, as loss of control, property damage or injury may result.

AVC – Active Vehicle Control

The Spektrum™ AVC® stabilization system adds a whole new level of control to your RC driving experience. AVC technology utilizes sensors to adjust steering and throttle output, providing you with a more stable and controlled driving experience.

Spektrum SRS4201

The Spektrum SRS4201 receiver features AVC technology that responds similar to traction control in full-scale vehicles. In addition to traction control, AVC technology also increases steering stability during high speed driving or while driving over rough terrain. As you increase the AVC sensitivity, the system increases steering stability and traction control, similar to reducing the amount of steering rate in a computer transmitter. Reducing the sensitivity value increases the amount of steering control from the transmitter. The SRS4201 receiver also enables you to quickly turn AVC on or off if you participate in organized racing.

IMPORTANT: You must use digital servos with the SRS4201 receiver. Using analog servos will reduce the performance of the system and may cause analog servos to overheat.

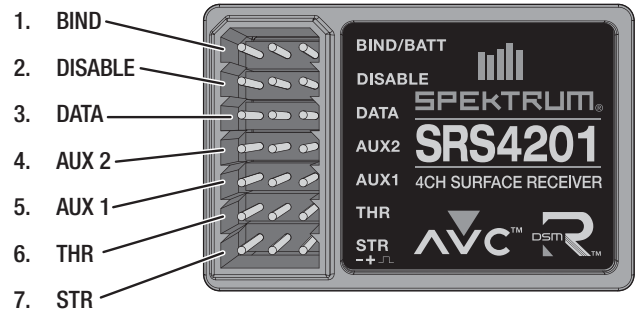

Adjusting AVC Sensitivity

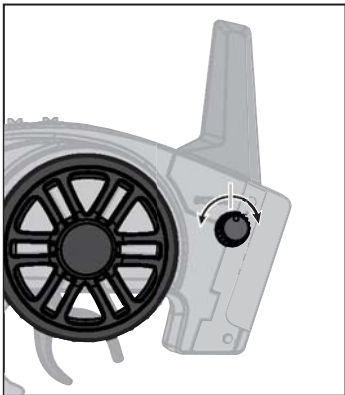

The **ST. RATE** dial adjusts the sensitivity, or stability, value in the receiver. If you increase the sensitivity, the AVC system becomes more sensitive to the vehicle drifting left or right. You would use maximum sensitivity during high speed driving or drag racing, when you want the vehicle to stay in a straight line. As the sensitivity value increases, the amount of steering travel decreases.

Turn the **ST. RATE** knob counter-clockwise to reduce the sensitivity.

Turn the **ST. RATE** knob clockwise to increase the sensitivity.

IMPORTANT: The **ST. RATE** knob will only adjust the sensitivity when the transmitter is bound to a DSMR™ receiver. When the transmitter is bound to a DSM®, DSM2® or DSM Marine receiver, the **ST. RATE** knob controls the steering dual rate.

Driving Precautions

- Maintain sight of the vehicle at all times.
- Inspect the vehicle for loose wheel hardware.
- Inspect the steering assembly for any loose hardware. Driving the vehicle off-road can cause fasteners to loosen over time.
- Stop driving the vehicle when you notice a lack of power. Driving the vehicle when the battery is discharged can cause the receiver to power off. You may lose control of the vehicle.

CAUTION: Do not discharge a LiPo battery below 3V per cell. Batteries discharged to a voltage lower than the lowest approved voltage may become damaged, resulting in loss of performance and potential fire when batteries are charged.

- Do not apply the throttle in forward or reverse if the vehicle is stuck. Applying throttle in this instance can damage the engine.
- Recommended to let the engine cool to ambient temperature between runs.

Fuel Safety and Use Instructions

- Always observe all warnings, precautionary statements and instructions supplied by the fuel manufacturer/provider.
- Fuel is a fire accelerant. Never operate your vehicle near open flames. Never smoke while operating your vehicle or while handling fuel.
- Always only use a mixture of gasoline and two-cycle oil for fuel. Do not use glow (nitro) fuel.
- Always use caution when handling gasoline.
- Always run your model engine in a well-ventilated area. Model engines produce harmful carbon monoxide fumes.
- Always drain your engine after you have finished running your vehicle. Do not store the vehicle with fuel in the gas tank.
- Never handle model engines and mufflers until they have had time to cool. They become extremely hot when in use.
- Always store your fuel in a safe place well away from sparks, heat or anything that can ignite.

- Always ensure that gasoline and fuel are stored in a clearly marked container well away from the reach of children.
- Always mix and store your fuel safely in a sealed, water-resistant container specifically made for gasoline.
- Always store fuel in a cool, dry location. Do not allow fuel containers to come in direct contact with concrete, as the fuel may absorb moisture.
- Always responsibly discard fuel if there is condensation and/or water inside the fuel container.
- Never allow fuel to come into contact with eyes or mouth. Gasoline and other fuels used in model engines are poisonous.
- Never return unused fuel from the fuel tank back into the fuel container.
- Contact your local waste disposal authorities for more information about discarding fuel waste responsibly.

Fuel Mixing Precautions and Guidelines

- Only use gasoline mixed with two-cycle engine oil.
- Only use Dynamite® Pre-Mix Two-Cycle Engine Oil (DYNE4105). Do not use any other kind of oil.
- Always use 92–98 Octane RON (Europe) and 91–93 Octane AKI (US) gasoline.
- Always blend gasoline with two-cycle engine oil at a 14:1 ratio.
- Never use a 40:1, 32:1 or 25:1 gas-oil ratio.
- Never use glow (nitro) fuel.

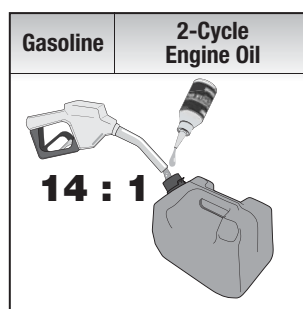

Gasoline : 2-Cycle Engine Oil

1 gallon	: 9.5 fl oz
1/2 gallon	: 4.8 fl oz
1/4 gallon	: 2.4 fl oz
4 liters	: 282 ml
2 liters	: 141 ml
1 liter	: 71 ml

Fueling the Truck

Remove the fuel tank cap and fill the fuel tank. Tighten the fuel tank cap securely back in place.

NOTICE: Running a loose fuel tank cap will cause inconsistency and high idle speed.

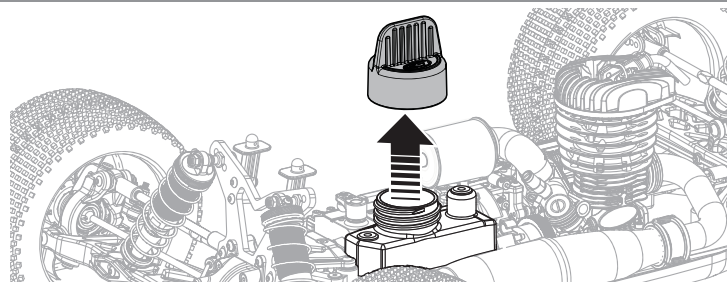

Vehicle Starting and Running with AVC

Priming the Carburetor

Before powering on the vehicle, turn on the starter box. Hold the vehicle securely with a finger over the exhaust port. Align the vehicle's flywheel with the starter box wheel. Briefly contact the flywheel with the starter box wheel for one second. The carburetor is now primed.

Remove your finger from the exhaust port, power on the vehicle and keep it immobile for 5-10 seconds to allow AVC to calibrate. Now the vehicle is ready to start. Use the starter box again, the engine should turn over and start up.

Priming the engine is typically not required for every start up. Only when the vehicle has been sitting for extended periods of time "cold start".

IMPORTANT: Always make sure the vehicle is motionless and on a level surface before powering on the vehicle. Each time you power on the vehicle, the Spektrum SRS4201 receiver automatically detects the receiver position (or orientation). The vehicle must remain motionless and level until the receiver calibration is complete (normally 5-10 seconds after powering on the vehicle). Moving the vehicle or not placing it on a surface will reduce the performance of the receiver.

1. Center the **ST. TRIM** and **TH. TRIM** dials on the transmitter.
2. Fill the fuel tank with 2-stroke gasoline (14:1 gasoline:oil ratio).
3. Power on the transmitter.
4. Power on the vehicle. The vehicle and receiver **MUST** remain motionless for at least 5 seconds.
5. Power on the Starter box.
6. Hold the vehicle securely and press it to the starter box. The engine should turn over and start up.

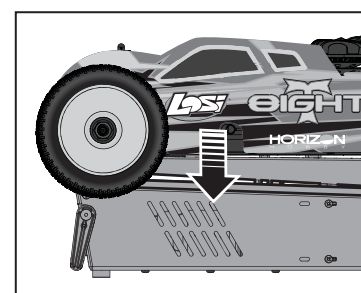
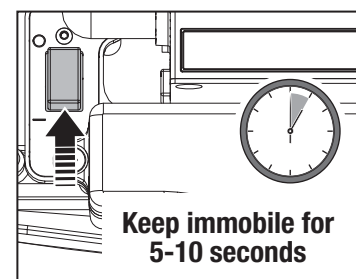
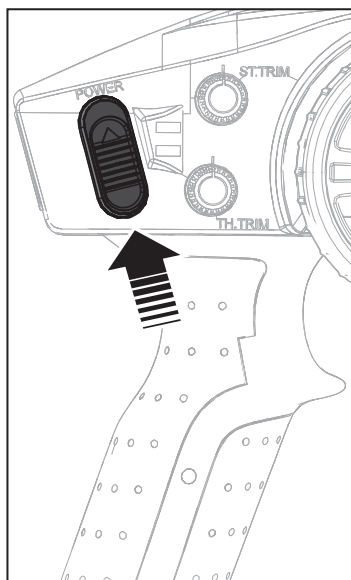

Follow the engine break-in procedure before attempting any racing or high-performance operation. Use caution when adding fuel while the engine is running. Do not over fill or spill fuel outside the tank.

Engine Break-In

Breaking in your new engine is critical for proper performance. Failure to follow the break-in procedures can cause engine damage and shortened engine life. Always use a 14:1 gasoline:oil mixture during the break-in process and when running the engine.

If you change fuel or run in dramatically different environments (hot/cold, high/low elevation, etc.) you will need to adjust the carburetor needles to prevent overheating and maintain proper performance. Never allow the engine to rev freely with the wheels off the ground.

Use the optional Dynamite Pro Temp Gun with Laser Sight (DYNP2000) to check engine temperatures.

Break-In Procedure:

CAUTION: You must complete the break-in process on a smooth surface, such as pavement or concrete. Do not drive the vehicle on dirt or grass during the break-in process; doing so will damage the engine.

NOTICE: Unlike nitro engines, do not allow the gasoline engine to idle for several tanks. Allowing the engine to idle prevents the engine from reaching operating temperature.

Fuel Tank #1:

1. Drive the vehicle in a figure 8 for the first tank of fuel. Keep the throttle position between 1/4 – 3/4 throttle. Do not exceed 3/4 throttle.

Engine temperature: Do not exceed **205°F (96°C)**

Fuel Tank #2:

1. During the second tank, move the throttle position between 1/4 and full throttle. Do not hold full throttle for more than one second.

Engine temperature: Do not exceed **210°F (99°C)**

Fuel Tanks #3-5:

1. Move the throttle position between 1/4 and full throttle. Do not hold full throttle for more than one second.

Engine temperature: Never exceed **220°F (104°C)**

Fuel Tank #6:

1. Lean the high speed needle 2-3 hours when the fuel level reaches 1/2 tank.
2. Move the throttle position between 1/4 and full throttle. Do not hold full throttle for more than two seconds.

Engine temperature: Do not exceed **235°F (112°C)**

Fuel Tank #7:

Move the throttle position between 1/4 and full throttle. Do not hold full throttle for more than two seconds.

Engine temperature: Never exceed **245°F (118°C)**

Fuel Tank #8:

1. Lean the high speed needle 1-2 hours when the fuel level reaches 1/2 tank.
2. Move the throttle position between 1/4 and full throttle. Do not hold full throttle for more than three seconds.

Engine temperature: Never exceed **255°F (123°C)**

Fuel Tanks #9-16:

After the end of Tank #8, the vehicle is ready to run on dirt surfaces. Maintain the same carburetor settings that were used during Tank #8 through Tank #16. After 8 tanks of fuel, you can tune the engine for peak performance.

Engine temperature: Never exceed **265°F (129°C)**

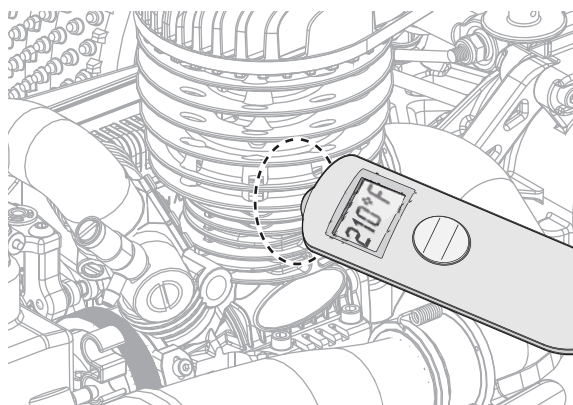
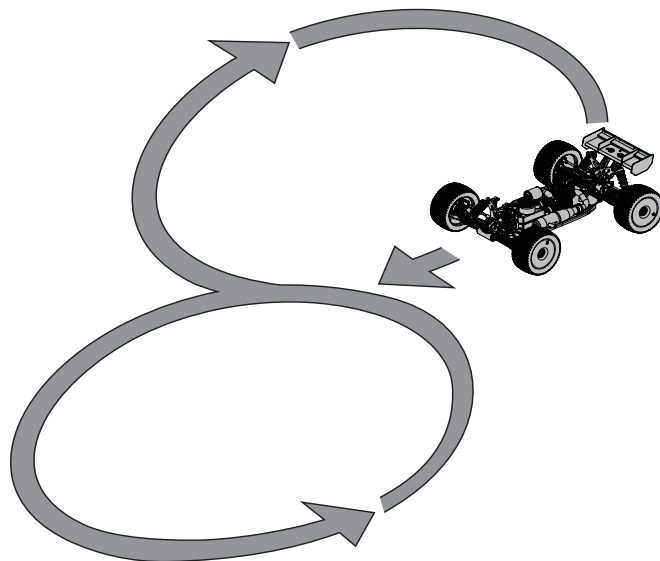

NOTICE: Engine temperatures are measured at the very bottom of engine head and not at the top of the head like a traditional nitro engine.

Vehicle Tuning

After the engine is broken in, you can tune it for optimum performance. When tuning, it is critical that you be cautious of overheating as severe damage and pre-mature wear can occur. You want to make all carburetor adjustments in "one hour" increments.

Before making adjustments:

- Ensure there are no leaks or obstructions in the fuel tank, fuel tubing or the carburetor. Any faults can affect engine operation and tuning.
- The carburetor needle is very sensitive. Adjusting the needle even 1/12 of a turn is a significant change. Be careful when making adjustments.

Factory Needle Settings:

Low Speed Needle: 18 hours from the bottom
High Speed Needle: 30 hours from the bottom

Carb Adjustments:

Make all carburetor adjustments in one-hour increments. Imagine the slot in the needle is the hour hand on a clock. Adjust it as though you were moving the hour hand from one hour to the next or previous one.

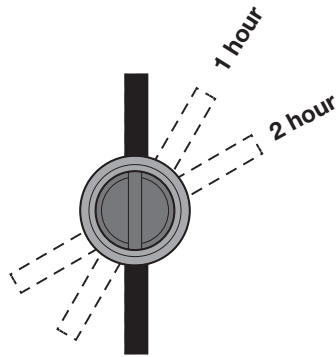

NOTICE: When making adjustments, only turn the needle 1/12 turn at a time.

Adjusting the High Speed Needle

Turn the high-speed needle until you achieve the ideal engine temperature and amount of exhaust smoke. The engine should have a noticeable smoke trail during initial acceleration and fade to a minor smoke trail when the engine reaches full throttle.

If the engine exceeds proper running temperature, 265 F (129 C), richen the high-speed needle immediately. If the engine temperature is very low considering normal running temperature, then lean the high-speed needle.

NOTICE: If the high-speed needle is too lean, it will cause a high idle speed.

Adjusting the Low Speed Needle-Idle Adjustment

Turn the low-speed needle to adjust the engine idle speed. Once you have achieved a proper idle speed, you can turn the low-speed needle by one hour in either direction to reach the optimal engine performance. Leaning (turn in) produces a higher idle speed. Richening (turn out) produces a lower idle speed.

Turning Off the Truck

1. To turn off the truck, simply move the truck's receiver power switch to the off position. This will eliminate power to the CDI and will turn off the engine.
2. Power off the transmitter.

High-Speed Needle (top, Right side). Close the high-speed needle by turning it clockwise until it stops, then turn it counterclockwise 30 hours out (open).

Low-Speed Needle (on the Left side). Close the low-speed needle by turning it clockwise until it stops, then turn it counterclockwise 18 hours out (open).

Idle Needle (Bottom of carburetor). The engine includes an idle needle for carburetor function, however it is not used for engine tuning. **DO NOT ADJUST THE IDLE NEEDLE.**

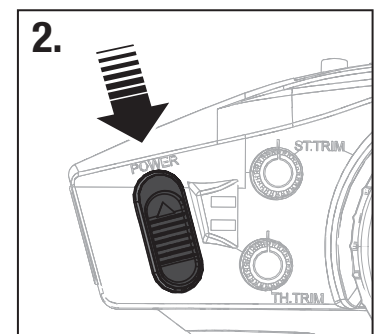
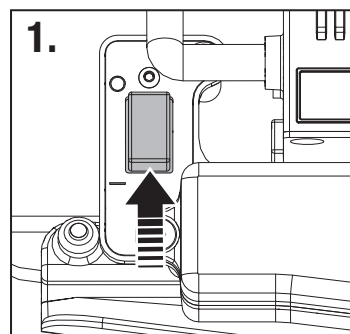
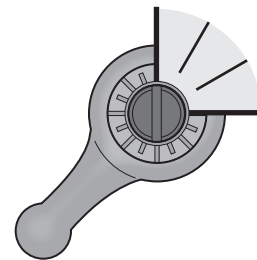
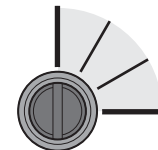

Troubleshooting Guide

Possible Cause	Solution
----------------	----------

ENGINE DOES NOT START

Out of fuel	Refill the tank and follow starting instructions.
Engine flooded	Remove the spark plug. Rotate engine using starter box. Replace and test
Air filter is clogged	Check and replace if necessary
Fuel mixture is old or bad	Mix fresh fuel per instructions
Spark plug is not working	Check the spark plug and ignition coil and replace if necessary
Throttle servo failed/Setup is wrong	Check servo operation. Set it to neutral and reset the linkage according to your radio and model manufacturer's specifications
Carburetor is incorrectly adjusted	Return the carburetor to the factory settings and retune if necessary
Piston and cylinder is worn	Check the piston and cylinder for wear or damage and replace if necessary
Vehicle's power switch is not in the ON position	Locate the power switch on the side of the receiver box and switch to ON position

ENGINE STARTS THEN STALLS

Out of fuel	Refill the tank and follow starting instructions
Air filter is clogged	Check and replace if necessary
Engine may be overheated	Let the engine cool. Richen the high speed needle
Engine idle is too low	Follow the instructions to increase idle speed
Carburetor is incorrectly adjusted	Return the carburetor to the factory settings and retune if necessary
Clutch is slipping or locked-up	Check the clutch for worn/broken lining or spring. Also check clutch bearings and ensure free rotation
Fuel mixture is old or bad	Mix fresh fuel per instructions
Throttle servo is improperly set up	Set the servo to neutral and reset the linkage according to radio and model manufacturer's specifications
Drivetrain is not functioning properly	Check the drivetrain for smooth operation/damage

ENGINE IS RUNNING, BUT VEHICLE DOES NOT MOVE

Brakes are stuck	Look for damage or foreign matter locking the brakes
Drivetrain is damaged	Check for damaged driveshaft or diff. Replace as needed
Receiver battery capacity is low	Charge the receiver battery
Radio is not responding despite charged battery	Make sure binding is properly set up

ERRATIC CONTROL

Transmitter and/or receiver batteries are weak	Install new batteries in the transmitter. Recharge the receiver battery
Connectors are inserted improperly	Check the connectors and reinstall if necessary
Brake is not working	Check the servo, brakes, and linkage for damage. Repair/replace/reset the servo linkage to factory settings
The steering gain is set too high	Turn down the steering gain
The throttle channel was reversed after calibration	Rebind and calibrate
The steering channel was reversed after calibration	Rebind and calibrate

Maintenance and Trouble Shooting

Binding and Calibrating the Receiver

In order to operate, the receiver must be bound to the transmitter. Binding is the process of programming the receiver to recognize the GUID (Globally Unique Identifier) code of a single specific transmitter. When a receiver is bound to a transmitter/model memory, the receiver will only respond to that specific transmitter/model memory.

You must calibrate the receiver each time it is placed in bind mode.

IMPORTANT: The following sequence of steps must be followed in order for AVC to function properly.

1. Insert the Bind Plug in the BIND port on the receiver.
2. Power on the receiver. The orange LED flashes, indicating the receiver is in bind mode.
3. Center the ST TRIM and TH TRIM on the transmitter.
4. Put your transmitter in bind mode.
5. The bind process is complete when the orange LED on the receiver is solid.
6. Pull the transmitter trigger to Full Throttle.
7. Push the transmitter trigger to Full Brake, then return the trigger to center.
8. Turn the transmitter steering wheel to Full Right.
9. Turn the transmitter steering wheel to Full Left, then return the steering wheel to center. The orange LED flashes once.
10. Remove the bind plug once the calibration and binding process is complete.
11. Power off the transmitter.

IMPORTANT: You must rebind the transmitter and receiver if you:

- Change the servo reverse after binding
- Change the travel after binding
- Want to use the receiver with a different model memory

If you change the servo reversing or travel adjust after binding, AVC will not work properly.

Disabling the Stability Assist Function

If you participate in organized racing, you may be required to turn AVC technology off. To turn off AVC technology, insert a second Bind Plug in the Disable port before binding.

IMPORTANT: You must calibrate the receiver each time it is placed in bind mode. To activate AVC, see the steps in BINDING AND CALIBRATING THE RECEIVER.

Failsafe

In the unlikely event that the radio connection is lost during use, the receiver will drive the servos to their pre programmed failsafe positions (normally no throttle and straight steering).

If the receiver is powered on before powering on the transmitter, the receiver will enter this failsafe mode. When the transmitter is powered on, normal control is resumed.

IMPORTANT: Failsafe activates only in the event that signal is lost from the transmitter. Failsafe will NOT activate in the event that receiver battery power decreases below the recommended minimums or power to the receiver is lost.

Changing the Travel Adjust Settings

The travel function supports precise endpoint adjustments in each direction for the steering and throttle channels.

1. Hold the trigger in the full brake position and steering wheel in the full right position while powering on the transmitter. The LED flashes rapidly, indicating the programming mode is active.
2. Throttle End Point: Hold the trigger in the full throttle position. Turn the TH TRIM knob to adjust the full throttle end point.
3. Brake End Point: Hold the trigger in the full brake position. Turn the TH TRIM knob to adjust the full brake end point. Return the trigger to the center position.
4. Left Steering End Point: Hold the steering wheel in the full left position. Turn the ST TRIM knob to adjust the left end point.
5. Right Steering End Point: Hold the steering wheel in the full right position. Turn the ST TRIM knob to adjust the right end point. Return the steering wheel to the center position.
6. Power off the transmitter to save the travel adjust settings. The minimum travel is 75% and the maximum travel is 150%. The default travel settings are 125% steering and 100% throttle.

Maintenance and Trouble Shooting

Adjusting Steering and Throttle Trims

Throttle Trim

Adjust the **TH. Trim** so the carburetor is completely closed when the throttle trigger is at neutral. If throttle can not be closed using **TH. Trim**, please take the following steps:

1. Make sure **TH. Trim** knob is set to "0" or neutral.
2. Loosen the drum barrel (**A**) at the end of the assembly with a hex wrench.
3. Tighten the drum barrel at the end of the assembly.

NOTICE: Throttle trim change may affect engine operation. Carburetor settings must be set correctly or damage may result.

See **Engine Tuning** for carburetor adjustments.

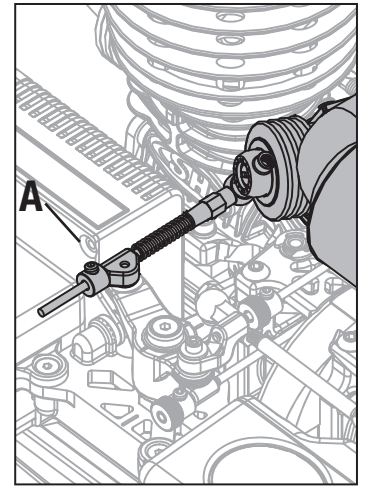
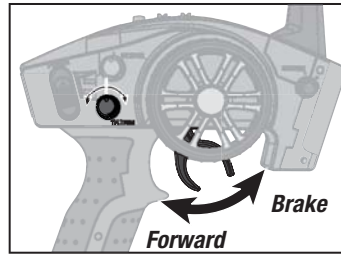

Steering Trim

The model should go straight without turning the steering wheel. If not, turn the **ST. Trim** knob in the direction needed for the model to go straight.

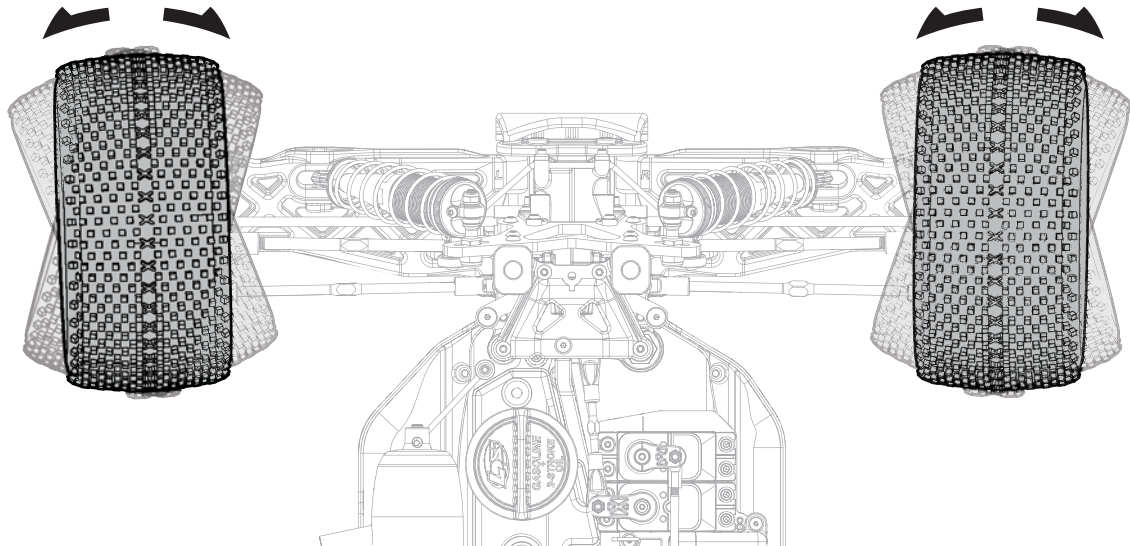
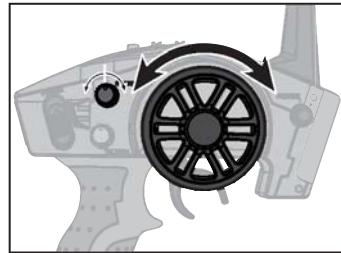

Maintenance and Trouble Shooting

Spark Plug Test

The spark plug used with your engine (DYNE0550) is designed specifically for the engine and is only available from Dynamite. Only use the spark plug with the designed cylinder head button (DYNE0513), as the head button creates the spark and controls the spark plug gap.

CAUTION: Before testing the spark plug, clean up spilled fuel and close fuel containers. Failure to do can result in injury, fire or damage.

Remove the spark plug from the engine and attach the plug wire and boot to the spark plug. Place the threaded end of the spark plug against the muffler. If there is no spark:

- Install a new spark plug (DYNE0550)

CAUTION: Do not test the spark plug near the spark plug hole or residual fuel may ignite.

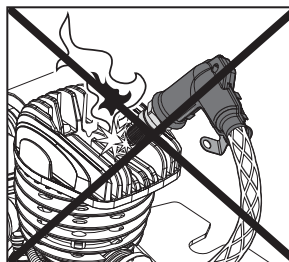
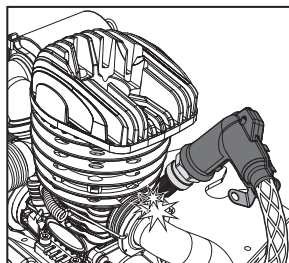

Flooded Engine

The engine will not start if too much fuel is in the cylinder. Excess fuel can be expelled by following the steps below.

1. Disconnect and remove the spark plug.
2. Install spin-start and rotat engine over for two seconds.
3. Replace the spark plug and make sure the boot is tightly secured.

NOTICE: Always clean up spilled fuel. Failure to do so may result in injury or damage.

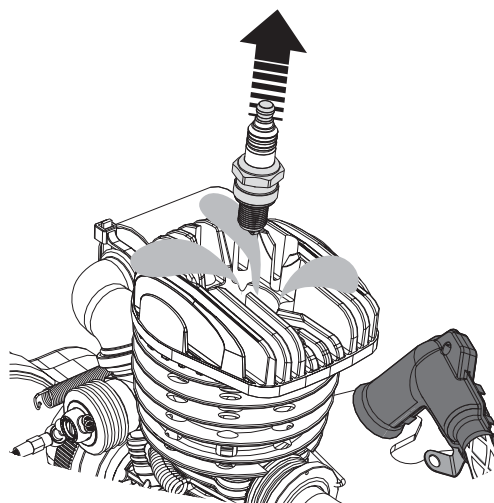

Limited Warranty

What this Warranty Covers

Horizon Hobby, LLC, (Horizon) warrants to the original purchaser that the product purchased (the "Product") will be free from defects in materials and workmanship at the date of purchase.

What is Not Covered

This warranty is not transferable and does not cover (i) cosmetic damage, (ii) damage due to acts of God, accident, misuse, abuse, negligence, commercial use, or due to improper use, installation, operation or maintenance, (iii) modification of or to any part of the Product, (iv) attempted service by anyone other than a Horizon Hobby authorized service center, (v) Product not purchased from an authorized Horizon dealer, or (vi) Product not compliant with applicable technical regulations.

OTHER THAN THE EXPRESS WARRANTY ABOVE, HORIZON MAKES NO OTHER WARRANTY OR REPRESENTATION, AND HEREBY DISCLAIMS ANY AND ALL IMPLIED WARRANTIES, INCLUDING, WITHOUT LIMITATION, THE IMPLIED WARRANTIES OF NON-INFRINGEMENT, MERCHANTABILITY AND FITNESS FOR A PARTICULAR PURPOSE. THE PURCHASER ACKNOWLEDGES THAT THEY ALONE HAVE DETERMINED THAT THE PRODUCT WILL SUITABLY MEET THE REQUIREMENTS OF THE PURCHASER'S INTENDED USE.

Purchaser's Remedy

Horizon's sole obligation and purchaser's sole and exclusive remedy shall be that Horizon will, at its option, either (i) service, or (ii) replace, any Product determined by Horizon to be defective. Horizon reserves the right to inspect any and all Product(s) involved in a warranty claim. Service or replacement decisions are at the sole discretion of Horizon. Proof of purchase is required for all warranty claims. SERVICE OR REPLACEMENT AS PROVIDED UNDER THIS WARRANTY IS THE PURCHASER'S SOLE AND EXCLUSIVE REMEDY.

Limitation of Liability

HORIZON SHALL NOT BE LIABLE FOR SPECIAL, INDIRECT, INCIDENTAL OR CONSEQUENTIAL DAMAGES, LOSS OF PROFITS OR PRODUCTION OR COMMERCIAL LOSS IN ANY WAY, REGARDLESS OF WHETHER SUCH CLAIM IS BASED IN CONTRACT, WARRANTY, TORT, NEGLIGENCE, STRICT LIABILITY OR ANY OTHER THEORY OF LIABILITY, EVEN IF HORIZON HAS BEEN ADVISED OF THE POSSIBILITY OF SUCH DAMAGES. Further, in no event shall the liability of Horizon exceed the individual price of the Product on which liability is asserted. As Horizon has no control over use, setup, final assembly, modification or misuse, no liability shall be assumed nor accepted for any resulting damage or injury. By the act of use, setup or assembly, the user accepts all resulting liability. If you as the purchaser or user are not prepared to accept the liability associated with the use of the Product, purchaser is advised to return the Product immediately in new and unused condition to the place of purchase.

Law

These terms are governed by Illinois law (without regard to conflict of law principals). This warranty gives you specific legal rights, and you may also have other rights which vary from state to state. Horizon reserves the right to change or modify this warranty at any time without notice.

WARRANTY SERVICES

Questions, Assistance, and Services

Your local hobby store and/or place of purchase cannot provide warranty support or service. Once assembly, setup or use of the Product has been started, you must contact your local distributor or Horizon directly. This will enable Horizon to better answer your questions and service you in the event that you may need any assistance. For questions or assistance, please visit our website at www.horizonhobby.com, submit a Product Support Inquiry, or call the toll free telephone number referenced in the Warranty and Service Contact Information section to speak with a Product Support representative.

Inspection or Services

If this Product needs to be inspected or serviced and is compliant in the country you live and use the Product in, please use the Horizon Online Service Request submission process found on our website or call Horizon to obtain a Return Merchandise Authorization (RMA) number. Pack the Product securely using a shipping carton. Please note that original boxes may be included, but are not designed to withstand the rigors of shipping without additional protection. Ship via a carrier that provides tracking and insurance for lost or damaged parcels, as Horizon is not responsible for merchandise until it arrives and is accepted at our facility. An Online Service Request is available at http://www.horizonhobby.com/content/_service-center_render-service-center. If you do not have internet access, please contact Horizon Product Support to obtain a RMA number along with instructions for submitting your product for service. When calling Horizon, you will be asked to provide your complete name, street address, email address and phone number where you can be reached during business hours. When sending product into Horizon, please include your RMA number, a list of the included items, and a brief summary of the problem. A copy of your original sales receipt must be included for warranty consideration. Be sure your name, address, and RMA number are clearly written on the outside of the shipping carton.

NOTICE: Do not ship LiPo batteries to Horizon. If you have any issue with a LiPo battery, please contact the appropriate Horizon Product Support office.

Warranty Requirements

For Warranty consideration, you must include your original sales receipt verifying the proof-of-purchase date. Provided warranty conditions have been met, your Product will be serviced or replaced free of charge. Service or replacement decisions are at the sole discretion of Horizon.

Non-Warranty Service

Should your service not be covered by warranty, service will be completed and payment will be required without notification or estimate of the expense unless the expense exceeds 50% of the retail purchase cost. By submitting the item for service you are agreeing to payment of the service without notification. Service estimates are available upon request. You must include this request with your item submitted for service. Non-warranty service estimates will be billed a minimum of ½ hour of labor. In addition you will be billed for return freight. Horizon accepts money orders and cashier's checks, as well as Visa, MasterCard, American Express, and Discover cards. By submitting any item to Horizon for service, you are agreeing to Horizon's Terms and Conditions found on our website http://www.horizonhobby.com/content/_service-center_render-service-center.

ATTENTION: Horizon service is limited to Product compliant in the country of use and ownership. If received, a non-compliant Product will not be serviced. Further, the sender will be responsible for arranging return shipment of the un-serviced Product, through a carrier of the sender's choice and at the sender's expense. Horizon will hold non-compliant Product for a period of 60 days from notification, after which it will be discarded.

Warranty and Service Contact Information

Country of Purchase	Horizon Hobby	Contact Information	Address
United States of America	Horizon Service Center (Repairs and Repair Requests)	servicecenter.horizonhobby.com/RequestForm/	4105 Fieldstone Rd Champaign, Illinois, 61822 USA
	Horizon Product Support (Product Technical Assistance)	www.quickbase.com/db/ bghj7ey8c?a= GenNewRecord	
		888-959-2306	
Sales	sales@horizonhobby.com 888-959-2306		
United Kingdom	Service/Parts/Sales: Horizon Hobby Limited	sales@horizonhobby.co.uk +44 (0) 1279 641 097	Units 1–4 , Ployters Rd, Staple Tye Harlow, Essex, CM18 7NS, United Kingdom
Germany	Horizon Technischer Service	service@horizonhobby.de	Christian-Junge-Straße 1 25337 Elmshorn, Germany
	Sales: Horizon Hobby GmbH	+49 (0) 4121 2655 100	
France	Service/Parts/Sales: Horizon Hobby SAS	infofrance@horizonhobby.com +33 (0) 1 60 18 34 90	11 Rue Georges Charpak 77127 Lieusaint, France
China	Service/Parts/Sales: Horizon Hobby – China	info@horizonhobby.com.cn +86 (021) 5180 9868	Room 506, No. 97 Changshou Rd. Shanghai, China 200060

FCC Information

This device complies with part 15 of the FCC rules. Operation is subject to the following two conditions: (1) This device may not cause harmful interference, and (2) this device must accept any interference received, including interference that may cause unde-sired operation.



CAUTION: Changes or modifications not expressly approved by the party responsible for compliance could void the user's authority to operate the equipment.

This product contains a radio transmitter with wireless technology which has been tested and found to be compliant with the applicable regulations governing a radio transmitter in the 2.400 GHz to 2.4835 GHz frequency range.

Antenna Separation Distance

When operating your Spektrum transmitter, please be sure to maintain a separation distance of at least 5 cm between your body (excluding fingers, hands, wrists, ankles and feet) and the antenna to meet RF exposure safety requirements as determined by FCC regulations.

The following illustrations show the approximate 5 cm RF exposure area and typical hand placement when operating your Spektrum transmitter.

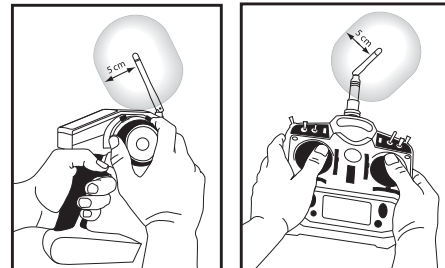

Compliance Information for the European Union

Declaration of Conformity

(in accordance with ISO/IEC 17050-1)

No. HH2014120204

Product(s): 8IGHT-T RTR, AVC: 1/8 4WD Gas Truggy
Item Number(s): LOS04001
Equipment class: 1

The object of declaration described above is in conformity with the requirements of the specifications listed below, following the provisions of the European R&TTE directive 1999/5/EC, EMC Directive 2004/108/EC and LVD Directive 2006/95/EC:

EN 300-328 V1.8.1
EN 301 489-1 V1.9.2: 2012
EN 301 489-17 V2.1.1: 2009

EN 60950-1:2006+A11:2009+A1:2010+A12: 2011
EN 62311:2008

EN55022:2010 + AC:2011
EN55024:2010



Signed for and on behalf of:
Horizon Hobby, LLC
Champaign, IL USA
December 1, 2014

Mike Dunne
Executive Vice President Product Divisions
Horizon Hobby, LLC

Instructions for Disposal of WEEE by Users in the European Union



This product must not be disposed of with other waste. Instead, it is the user's responsibility to dispose of their waste equipment by handing it over to a designated collection point for the recycling of waste electrical and electronic equipment. The separate collection and recycling of your waste equipment at the time of disposal will help to conserve natural resources and ensure that it is recycled in a manner that protects human health and the environment. For more information about where you can drop off your waste equipment for recycling, please contact your local city office, your household waste disposal service or where you purchased the product.



Name: 8IGHT-T Standard Setup		Date: _____	Event: _____
City: _____ State: _____		Track: _____	
Track Conditions: <input type="checkbox"/> Indoor <input type="checkbox"/> Tight <input type="checkbox"/> Smooth <input type="checkbox"/> Hard Packed <input type="checkbox"/> Blue Groove <input type="checkbox"/> Wet <input type="checkbox"/> Low Bite <input type="checkbox"/> High Bite <input type="checkbox"/> Outdoor <input type="checkbox"/> Open <input type="checkbox"/> Rough <input type="checkbox"/> Loose/Loamy <input type="checkbox"/> Dry <input type="checkbox"/> Dusty <input type="checkbox"/> Med Bite <input type="checkbox"/> Other _____			

Front Suspension

Toe: 1° Toe Out

Ride Height: 29mm

Camber: -2°

Caster: 27°

Wheel Hex: Standard Hex

Sway Bar: 2.3mm

Piston/Oil: 8 Hole 1.3mm/40 wt

Spring: Green 4.8 lbs.

Limiters/Droop: 102.5mm

Overall Shock Length: _____

Steering Ackerman: Long

Bump Steer: Up

Camber Link: 3

Shock Location: 1/Outside

Receiver Battery Type: 2S LiPo

Differentials

Front: Standard Smart

Spring Wire Dia: _____

Qty of Springs: _____

Ramp Plate: _____

Grease: _____

Diff Fluid: 5000 wt

Center: Standard Smart

Spring Wire Dia: _____

Qty of Springs: _____

Ramp Plate: _____

Grease: _____

Diff Fluid: 7000 wt

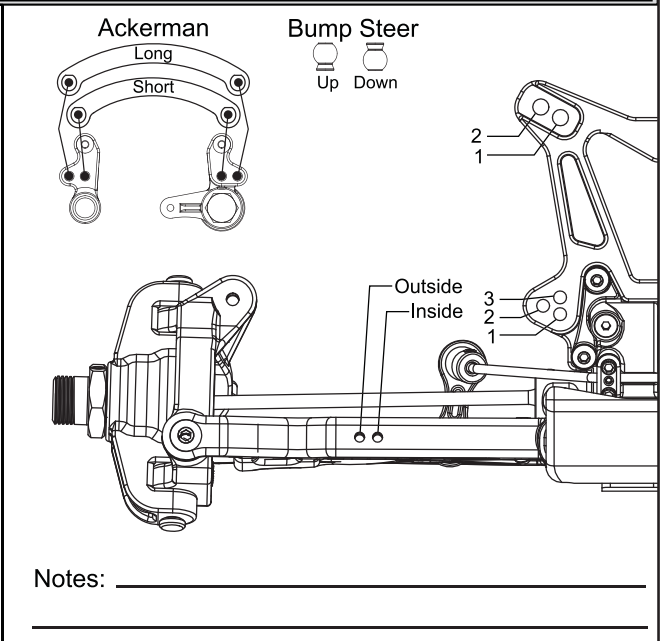

Rear Suspension

Roll Center: HRC LRC

Toe: 3°

Anti-Squat: 3°

Ride Height: 29mm

Camber: -2

Rear Hub Spacing: Back

Wheel Hex: +1mm Hex

Sway Bar: 2.3mm

Piston/Oil: Split/25 wt

Spring: Silver 3.6 lbs

Limiters/Droop: 114mm

Overall Shock Length: _____

Camber Link: 1/B

Shock Location: 2/Outside

Rear Diff Fluid: 3000 wt

Wing Setup

Wing Type: 2.0 3.0

Wing Spacer: .250 .500

Wicker Bill: .250 .350

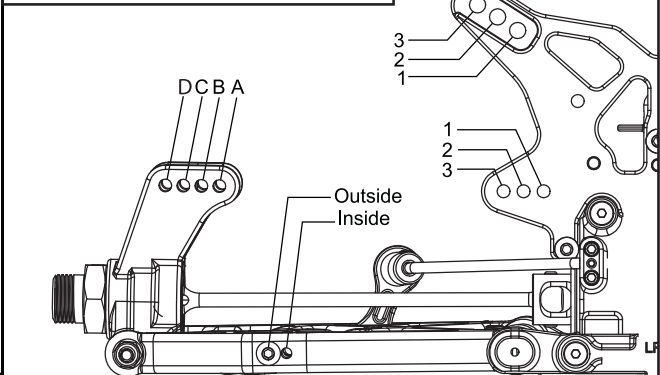

Engine

Engine: _____ Fuel: _____

Spark Plug: _____ Head Clearance: _____

Pipe/Header: _____ Gearing: _____

Clutch

Clutch Shoes and Springs Info

Tires

Type	Compound	Insert
Front: _____	_____	_____
Rear: _____	_____	_____
Notes: _____		

Name: _____	Date: _____ Event: _____
City: _____ State: _____	Track: _____

Track Indoor Tight Smooth Hard Packed Blue Groove Wet Low Bite High Bite
 Conditions Outdoor Open Rough Loose/Loamy Dry Dusty Med Bite Other _____

Front Suspension

Toe: _____
 Ride Height: _____
 Camber: _____
 Caster: _____
 Wheel Hex: _____
 Sway Bar: _____
 Piston/Oil: _____
 Spring: _____
 Limiter/Droop: _____
 Overall Shock Length: _____
 Steering Ackerman: _____
 Bump Steer: _____
 Camber Link: _____
 Shock Location: _____
 Receiver Battery Type: _____

Differentials

Front: Standard Smart
 Spring Wire Dia: _____
 Qty of Springs: _____
 Ramp Plate: _____
 Grease: _____
 Diff Fluid: _____

Center: Standard Smart
 Spring Wire Dia: _____
 Qty of Springs: _____
 Ramp Plate: _____
 Grease: _____
 Diff Fluid: _____

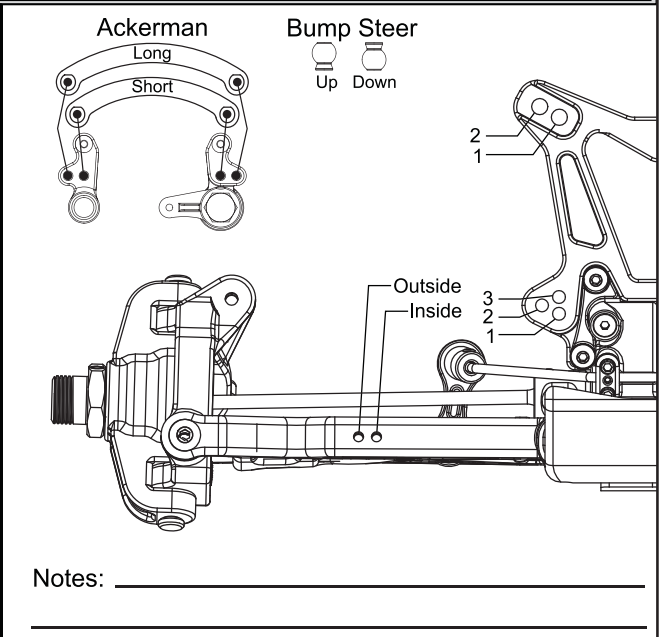

Rear Suspension

Roll Center: HRC LRC
 Toe: _____
 Anti-Squat: _____
 Ride Height: _____
 Camber: _____
 Rear Hub Spacing: _____
 Wheel Hex: _____
 Sway Bar: _____
 Piston/Oil: _____
 Spring: _____
 Limiter/Droop: _____
 Overall Shock Length: _____
 Camber Link: _____
 Shock Location: _____
 Rear Diff Fluid: _____

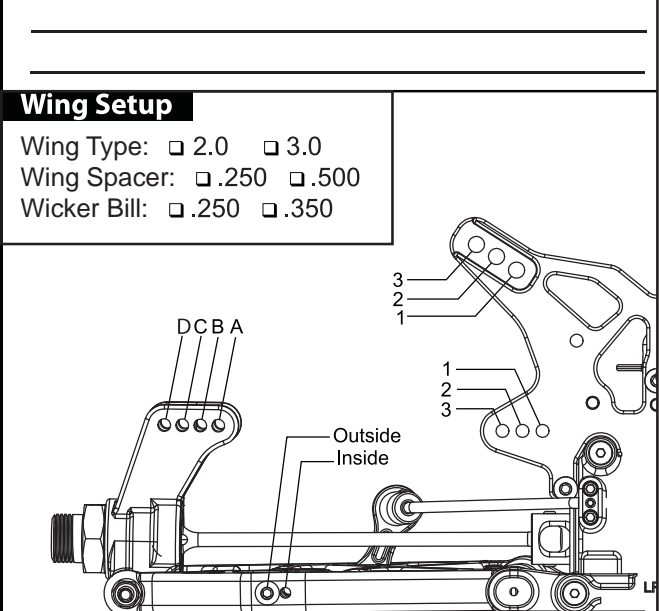

Engine

Engine: _____ Fuel: _____
 Spark Plug: _____ Head Clearance: _____
 Pipe/Header: _____ Gearing: _____

Clutch

Clutch Shoes and Springs Info

Tires

Type	Compound	Insert
Front: _____	_____	_____
Rear: _____	_____	_____
Notes: _____	_____	_____

Replacement Parts List • Teileliste • Liste des pièces de rechange

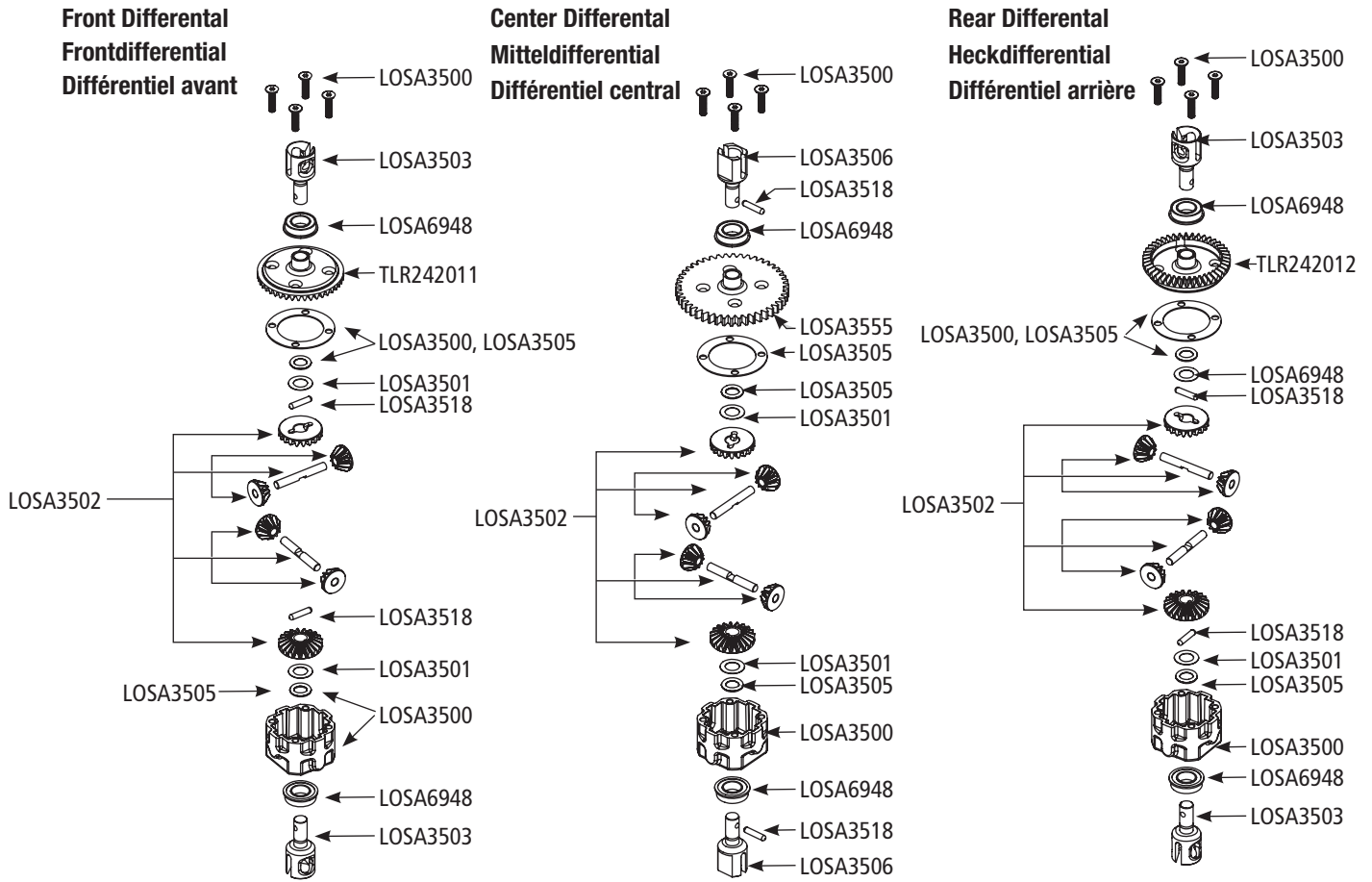

Part #	English	Deutsch	Français
LOSA3500	Diff Housing F/R/C: 8B,8T	Losi 8B,8T: Diff-Gehäuse F/Z/H	8B/8T - Corps de diff F/R/C
LOSA3501	Differential Shims, 6x11x.2mm: 8B 2.0 (12)	Losi 8B 2.0: Diff-Unterlegscheiben 6x11x.2mm	8B 2.0 - Cales de différentiel 6x11x.2mm
LOSA3502	Differential Gear & Shaft Set: 8B,8T	Losi 8B, 8T: Diff Zahnr. u. Wellen Set	8B/8T - Pignon & axes de diff
LOSA3503	Front/Rear H.D. Differential Outdrive Cups & Pins	Fr/R HD Outdrive Set (2): 8 B,T,LST,2	Noix de cardan Av/R HD (Pr): 8 B,T,LST,2
LOSA3505	Differential Seal Set: 8B,8T, LST, XXL, MB	Losi 8B/T,LST: Diff-Dichtungs Set	8B/8T/LST/ XXL/MB - Jeu de joints de différentiel
LOSA3506	Center Differential Outdrive Cups & Pins	Antriebsklaue für Mitteldiff : 8B,8T	Noix de cardan coupelles diff cent. & goupilles: 8B,8T
LOSA3510	Rear Differential Ring Gear: 8B	Losi 8B: Tellerrad 43T Diff hinten	Couronne de diff arr.: 8B
LOSA3518	Drive Pin Set: 8B/8T	Losi 8B/8T Mitnehmerstift 8B/8T	Goupilles: 8B/8T
LOSA3355	Center Diff 50T Spur Gear, Lightweight: 8B/8T	Losi 8B 2.0: Antriebswelle Mitte/Hinten inkl. Zubehör	Couronne centrale 50T, allégé: 8B/8T
LOSA6948	8x14x4 Flanged Rubber Seal Ball Bearing (4)	Losi 8x14x4 Kugellager (4)	8x14x4 Roulement a billes étanches (4)
TLR242011	Front Ring and Pinion Gear Set: 8IGHT-T 3.0	Der Ring und das Ritzel Set: 8ight-T 3.0	Avant Jeu de couronne et de pignon : 8ROITE-T 3.0
TLR242012	Rear Ring and Pinion Gear Set: 8IGHT-T 3.0	Hinterer Ring und Ritzel Set: 8ight-T 3.0	Bague arrière et jeu de pignon d'attaque : 8ROITE-T 3.0

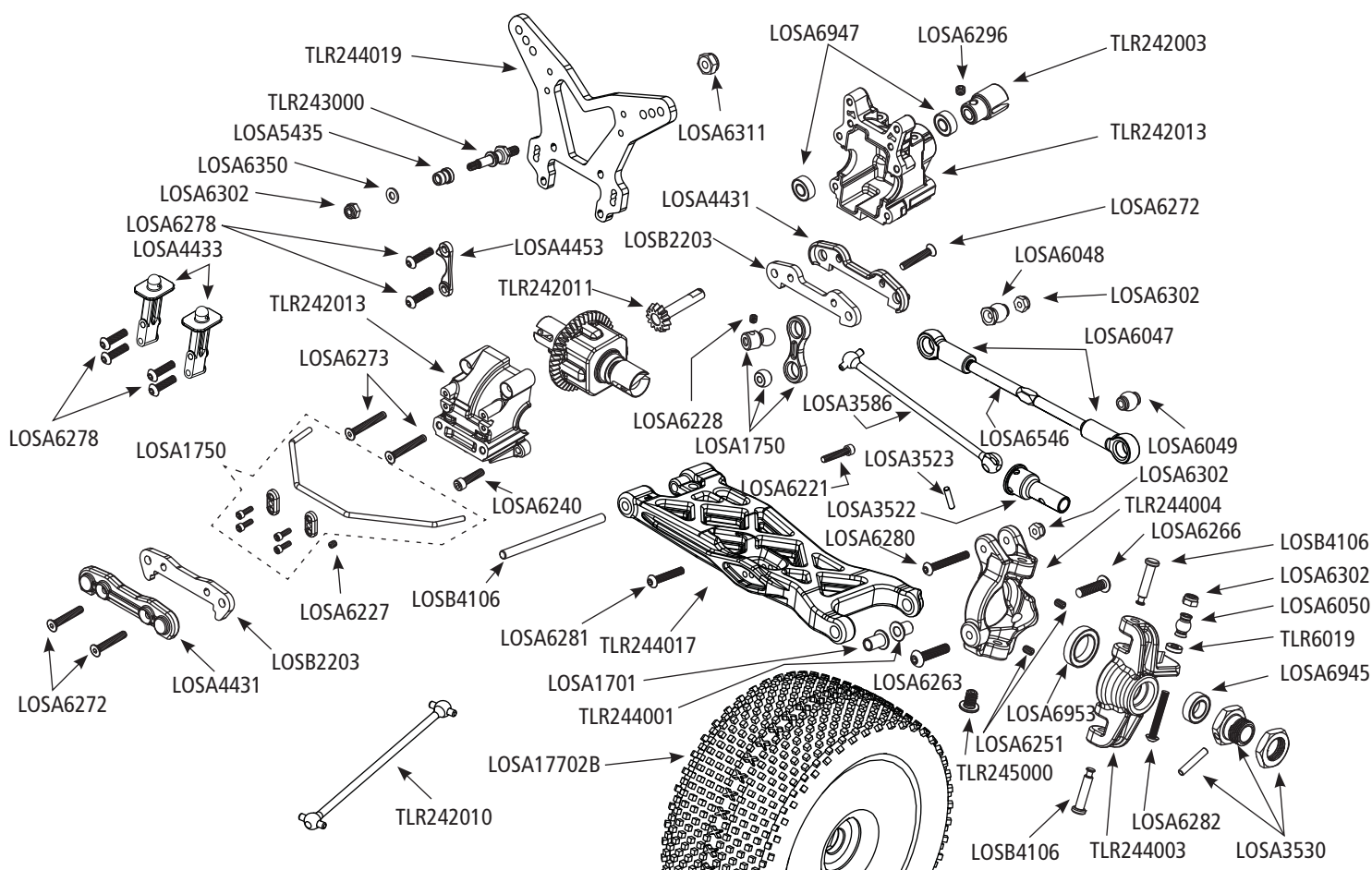

Part #	English	Deutsch	Français
LOSA1701	Front Suspension Arm Bushings:8B,8T	Buchse für Querlenker Vorne:8B,8T	Bagues de triangle av.:8B,8T
LOSA1750	LOSA1750 Sway Bar Set: 8B, 8T	Losi 8B,8T: Stabilisator Set	Jeux de barre anti-roulis: 8B,8T
LOSA3522	F/R CV Driveshaft Axles(2): 8B,8T	Losi 8B/8T: F/H CV Antriebsachse Achse(2)	Axes de cardans F/R CV(Pr): 8B,8T
LOSA3523	F/R CV Driveshaft Coupling Set: 8B,8T	Losi 8B / 8T: F/H CV Antriebsachse Coupling Set	Coupleurs de cardans F/R CV : 8B,8T
LOSA3530	Wheel Hexes (Pr) Hard Anodized: 8B,8T	Losi 8B /8T:Radmitnehmer (Pr) gehärtet	Hexagone de Jantes (Pr) Anodisé dur: 8B,8T
LOSA3586	Front/Rear CV Drive Shafts (2): 8T 2.0	Antriebswellenset vorne/hinten: 8T 2.0	8T 2.0 - Tiges de cardans CVD av/arr. (2)
LOSA4431	Hinge Pin Brace Cover Set: 8B, 8T	Losi Losi Hinge Pin Brace Cover Set: 8B/ 8T	Protections de cales : 8B, 8T
LOSA4433	Body Posts: 8T 2.0	Losi Karosserie Halter: 8T 2.0	8T 2.0 - Plots de carrosserie
LOSA4453	Chassis Spacer/Cap Set: 8B 2.0	Losi Distanz und Befestigungs Set: 8B 2.0	Entretoises plastiques: 8B 2.0
LOSA5435	15mm Shock Ends, Cups, Bushing: 8B 2.0	Kugellendpfanne, Kugel, Buchsen und Federteller für 15mm Stoßdämpfer: 8B 2.0	8B 2.0 - Chapes et coupelles d'amortisseurs 15mm.
LOSA6047	5mm Rod End Set: 8B, 8T	Losi 5mm Kugelpfannen Set: 8B/ 8T	8B/8T - Chapes 5mm (8)
LOSA6048	Suspension Balls 8.8mm Flanged: 8B,8T	Losi Kugelkopf m. Flansch 8.8mm: 8B,8T	8B/8T - Rotules épaulées 8.8mm (4)
LOSA6049	Suspension Balls 8.8mm: 8B,8T	Losi Kugelkopf m. Flansch: 8B,8T	8B/8T - Rotules 8.8mm (4)
LOSA6050	Steering Ball Set 6.8mm: 8B,8T	Losi Kugelkopf Lenkung: 8B,8T	8B/8T - Rotules de direction 6.8mm (2 paires)
LOSA6221	4-40 x 5/8" Cap Screws	Losi 4-40 x 5/8 Zylinderkopfschrauben	Vis chc 4-40 x 5/8 (6)
LOSA6227	Hardened Setscrews,4-40	Losi Madenschrauben gehärtet 4-40	Vis sans tête 4-40 (10)
LOSA6228	Hardened Setscrews,5-40	Losi Madenschrauben gehärtet 5-40	Vis sans tête 5-40 (10)
LOSA6240	5-40 x 1/2 Caphead Screw (8)	Losi 5-40 x 1/2 Zylinderkopfschrauben (8)	Vis chc 5-40 x 1/2 vis (8)
LOSA6251	5-40X3/16" Set Screw(10)	Losi 5-40X3/16 Madenschrauben	Vis sans tête 5-40 x 3/16" (10)
LOSA6263	8-32 x 3/4" BH Screws (8)	Losi 8-32 x 3/4 Rundkopfschrauben (8)	Vis tête bombée 8-32 x 3/4 (8)
LOSA6266	8-32 x 5/8" BH Screws	Losi 8-32 x 5/8 Rundkopfschrauben	Vis tête bombée 8-32 x 5/8" (8)
LOSA6272	5-40 x 3/4" FH Screws (10)	Losi 5-40 x 3/4 Flachkopfschrauben (10)	Vis à tête fraisée5-40 x 3/4 (10)
LOSA6273	5-40 x 7/8" FH Screws (4)	Losi 5-40 x 7/8 Flachkopfschrauben (4)	Vis à tête fraisée 5-40 x 7/8 (4)
LOSA6278	5-40 x 1/2" BH Screws (8)	Losi 5-40 x 1/2 Rundkopfschrauben (8)	Vis tête bombée 5-40 x 1/2 (8)
LOSA6280	5-40 x 1" BH Screws (4)	Losi 5-40 x 1 Rundkopfschrauben (4)	Vis tête bombée 5-40 x 1 (4)
LOSA6281	5-40 x 20mm Button Head Screws (10)	Losi 5-40 x 20mm Rundkopfschrauben (10)	Vis tête bombée 5-40 x 20mm (10)
LOSA6282	5-40 x 7/8" BH Screws	Losi 5-40 x 7/8 Rundkopfschrauben	Vis tête bombée 5-40 x 7/8
LOSA6296	8-32 x 1/8 Flat Point Setscrew-8	Losi 8-32 x 1/8 Madenschraube-8	Vis pointeau bout plat 8-32 x 1/8 (8)
LOSA6302	5-40 Locking Nuts,Steel	Losi Stopmmutter 5-40 Stahl (4)	Ecrou Frein acier 5-40 (4)
LOSA6311	8-32 Steel Lock Nuts (10)	Losi 8-32 Stahl Stopmutter (10)	8-32 acier Nylstop (10)
LOSA6350	#4 and 1/8" Hardened Washers	Losi Unterlegscheiben #4 und 1/8 gehärtet	Rondelles #4 et 1/8
LOSA6546	Turnbuckles, 5 x 107mm with Ends	Gewindestift L/R, 5 x 107mm m. E	Biellettes 5mm x 107mm avec rotules
LOSA6953	1/2 x 3/4 Rubber Sealed Ball Bearing	1/2 x 3/4 Kugellager gekapselt	Roulements étanches 1/2 x 3/4 (2)
LOSB2203	Hinge Pin Brace Set: 8RTR	Losi Hinge Pin Brace Set: 8RTR	Jeux de traverses d'axe de suspension: 8RTR
LOSB4106	Hinge Pin Set: 8RTR	Losi Hinge Pin Set: 8RTR	Jeux d'axes de suspension: 8RTR

Part #	English	Deutsch	Français
TLR6019	Ballstud/Hub Spacer Set, Aluminum: 22	TLR Distanzringe für Kugelkopf Aluminium: 22	22 - Set d'entretoises de rotules
TLR242003	Coupler Outdrive (2): 8IGHT 3.0	TLR 8ight 3.0 :Kupplungsstück für Antriebsklaue (2)	8B 3.0 - Noix d'accouplement de cardan (2)
TLR242010	Center Dog Bone Set, Front and Rear: 8T 3.0	Antriebsknochenset v/h: 8T 3.0	8T 3.0 - Cardan central av et arr
TLR242011	Front Ring and Pinion Gear Set: 8T 3.0	Kegelrad vorne u. Ritzelset: 8T 3.0	8T 3.0 - Couronne et pignon de diff av
TLR242013	Front and Rear Gear Box Set: All 8IGHT	Getriebekasten Vorne und Hinten : TLR 8ight 3.0	8B 3.0 - Boîtier de transmission avant et arrière
TLR243000	Shock Stand-off Set (2): 8B 3.0	TLR 8ight 3.0 Stehbolzen für Dämpferbefestigung (2)	8B 3.0 - Entretoises d'amortisseurs (2)
TLR244001	Front Suspension Arm Bushing (4): 8B 3.0	TLR 8ight 3.0 Buchsen für Querlenker Vorne (4)	8B 3.0 - Paliers de triangles avant (4)
TLR244003	Front Spindle Set: 8B 3.0	TLR 8ight 3.0 Lenkhebel	8B 3.0 - Jeu de fusées avant (2)
TLR244004	Front Spindle Carrier, 15 Degree: 8B 3.0	TLR 8ight 3.0: Lenkhebelträger 15 Grad	8B 3.0 - Etrier porte fusée avant, 15° (2)
TLR244017	Front Suspension Arm Set: 8T 3.0/2.0	Querlenkersatz vorne: 8T 3.0/2.0	8T 2.0/3.0 - Triangles de suspension avant
TLR244019	Front Shock Tower, Aluminum: 8IGHT-T 3.0	Dämpferbrücke vorne Aluminium: 8T 3.0	8T 3.0 - Support d'amortisseurs avant en aluminium
TLR245000	Droop Screw (4): 8B 3.0	TLR 8ight 3.0: Ausfederungsbegrenzer (4)	8B 3.0 - Butée (4)
LOSA17702B	1/8 XTT TruggyTire,BI,Mntd,w/Yel Whl, 0 Offset (2)	1/8 XTT TruggyTire,BI,Mntd,w/Yel Whl, 0 Offset 2.	1/8 XTT TruggyTire,BI,mural,w/Yel Whl, 0 Oeedéfinir (2)

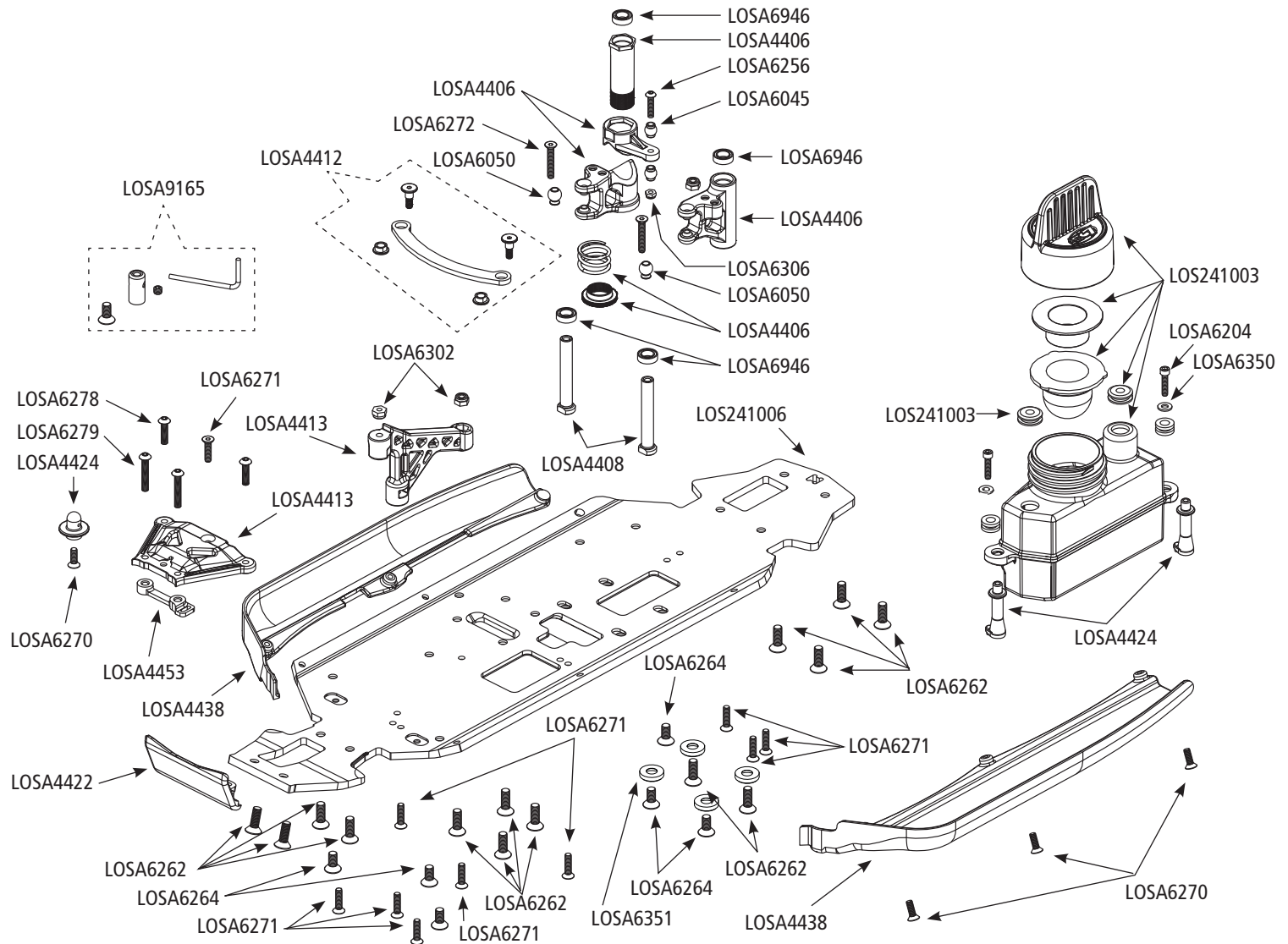

Part #	English	Deutsch	Français
LOSA4406	Steering Bellcrank Plastics & Servo Saver: 2.0	Losi 2.0 : Lenkhebel Kunststoff & Servo Saver	8B 2.0 - Palonnier de direction, renvois & Sauve servo
LOSA4408	Steering Post Set: 8B,8T	Losi 8B8T: Lenkhebelhalter	8B/8T - Pivot de direction (2)
LOSA4412	Steering Rack Set, Short/Long: 8B 2.0	Losi Lenkhebel kurz/lang: 8B 2.0	Jeux de barres de direction, Courte/Longue: 8B 2.0
LOSA4413	Front Chassis Brace Set: 8B,8T	Losi Chassishalter vorne: 8B,8T	8B/8T - Renforts de châssis avant (2)
LOSA4422	FR Bumper,Tank,Filter Guard: 8B, 8T	Losi Stoßfänger, Tankschutz, Filterhalter: 8B, 8T	8B/8T - Pare choc av ,réservoir,protection de filtre
LOSA4424	Body Posts & Tank Mounts: 8B, 8T	Losi Karosserie Halter und Tank Befestigung: 8B/ 8T	8B/8T - Plots de carrosseries & support de réservoir
LOSA4438	Chassis Guard Set: 8T 2.0	8T 2.0 - Protections de châssis	Set protezone telaio: 8T 2.0
LOSA4453	Chassis Spacer/Cap Set: 8B 2.0	8B 2.0 - Diverses entretoises en plastique	Set distanziali telaio: 8B 2.0
LOSA6045	HD Steering Link Set: 8B 2.0	Anschluss Lenkgestäbe: 8B 2.0	8B 2.0 - Tringlerie courte de direction
LOSA6050	Steering Ball Set 6.8mm: 8B,8T	Losi Kugelkopf Lenkung: 8B,8T	8B/8T - Rotules de direction 6.8mm (2 paires)
LOSA6204	4-40 x 1/2 Socket Head Screw	Losi 4-40 x 1/2 Zylinderkopfschrauben	Vis chc 4-40 x 1/2

Part #	English	Deutsch	Français
LOSA6256	4-40 x 1/2 Button Head Cap Screw (6)	Losi 4-40 x 1/2 Rundkopfschrauben (6)	Vis tête bombée 4-40 x 1/2 (6)
LOSA6262	8-32 x 1/2" FH Screws (10)	Losi 8-32 x 1/2 Flachkopfschrauben (10)	Vis à tête fraisée 8-32 x 1/2 (10)
LOSA6264	8-32 x 3/8" FH Screws (8)	Losi 8-32 x 3/8 Flachkopfschrauben (8)	Vis à tête fraisée 8-32 x 3/8 (8)
LOSA6270	5-40 x 3/8" Flat Head Screws (10)	Losi 5-40 x 3/8 Flachkopfschrauben (10)	Vis à tête fraisée 5-40 x 3/8 (10)
LOSA6271	5-40 x 1/2" FH Screws (10)	Losi 5-40 x 1/2 Flachkopfschrauben (10)	Vis à tête fraisée 5-40 x 1/2 (10)
LOSA6278	5-40 x 1/2" BH Screws (8)	Losi 5-40 x 1/2 Rundkopfschrauben (8)	Vis tête bombée 5-40 x 1/2 (8)
LOSA6279	5-40 x 3/4" BH Screws (8)	Losi 5-40 x 3/4 Rundkopfschrauben (8)	Vis tête bombée 5-40 x 3/4 (8)
LOSA6350	#4 and 1/8" Hardened Washers	Losi Unterlegscheiben #4 and 1/8 gehärtet	Rondelles #4 et 1/8
LOSA6351	#8 Countersink Washers (8)	Losi Unterlegscheibe #8 mit Bund (8)	Rondelles cuvettes #8 (8)
LOSA6302	5-40 Locking Nuts, Steel	Losi Stopmmutter 5-40 Stahl (4)	Ecrou Frein acier 5-40 (4)
LOSA6306	4-40 Aluminum Mini-Nuts (10)	Losi 4-40 Aluminium Mini-Muttern (10)	Mini écrou frein 4-40 (10)
LOSA6946	6x10x3 Rubber Sealed Ball Bearing (4)	Losi 6x10x3 Kugellager gekapselt(4)	Roulements étanches 6x10x3 (4)
LOSA9165	Tuned Pipe Mount & Hardware: 8B,8T	Losi 8B,8T: Halter Tuningschalldämpfer m Zbh.	8B/8T - Fixation de résonateur
LOS241003	Fuel Tank, Gasoline: 8IGHT/T RTR	Losi 8IGHT/T RTR: Tank	Réservoir de carburant, thermique: 8IGHT/T RTR
LOS241006	Chassis, Gasoline: 8IGHT-T RTR	Losi 8IGHT-T RTR: Chassis Benziner	Châssis, thermique: 8IGHT/T RTR

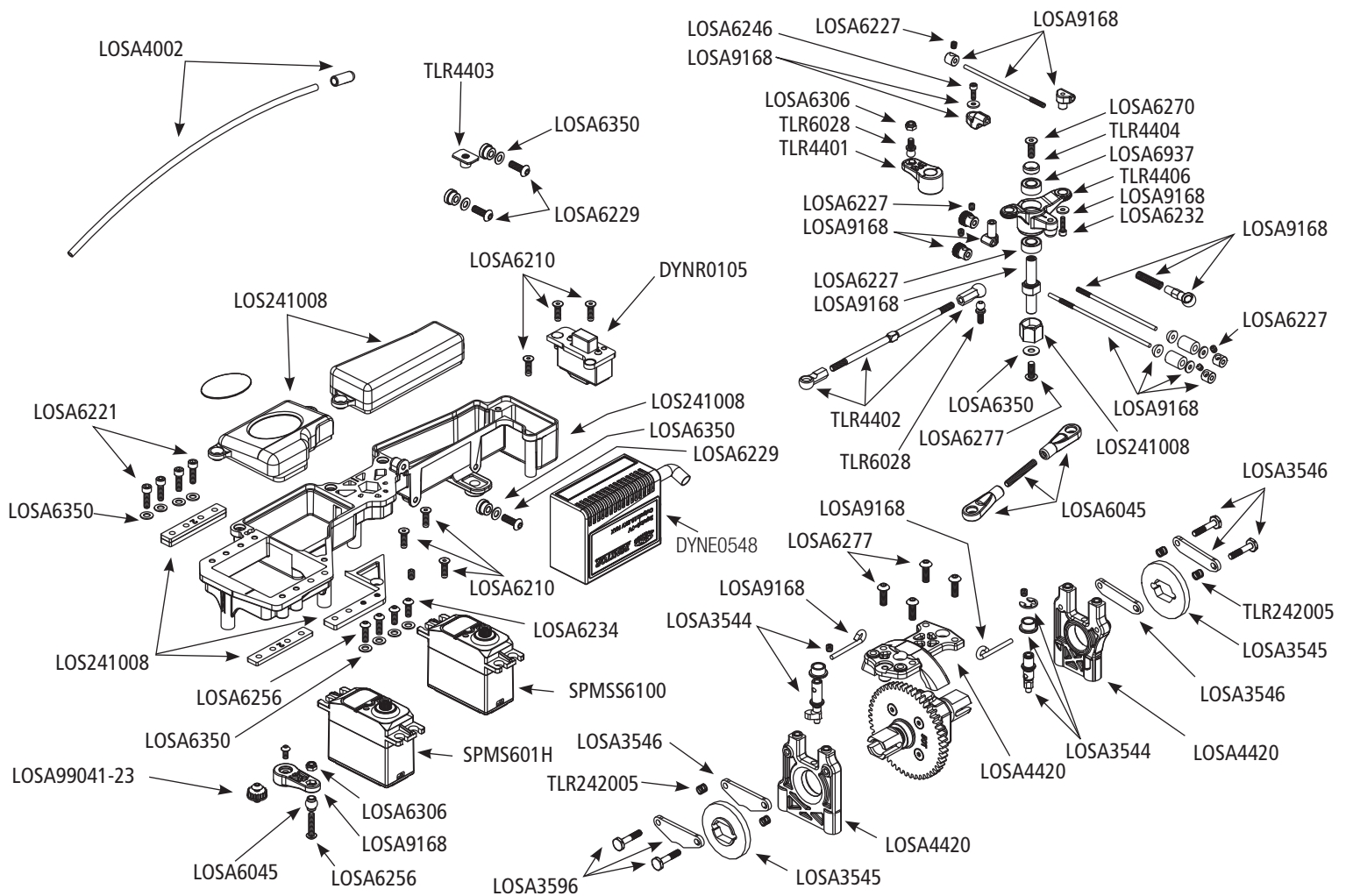

Part #	English	Deutsch	Français
LOSA3544	Brake Cam Set: 8B,8T	Losi 8B/8T: Bremsexenter Set	8B/8T - Jeu de cames de frein
LOSA3545	Brake Disk Set: 8B 2.0	Losi 8B 2.0: Bremsscheiben Set	8B 2.0 - Jeu de disques
LOSA3546	Brake Pads & Screws: 8B 2.0	Losi 8B 2.0: Bremsbeläge u. Schrauben	8B 2.0 - Plaquettes de frein & écrous
LOSA4002	Antenna Kit	Losi Antennen Kit	Tube d'antenne avec fixations
LOSA4420	Center Differential Mount & Brace Set: 8B 2.0	Losi Mitteldiffbock/Hauptzahnradschutz Set: 8B 2.0	8B 2.0 - Support de diff cent. & entretoises
LOSA6045	HD Steering Link Set: 8B 2.0	Anschluss Lenkgestänge: 8B 2.0	8B 2.0 - Tringlerie courte de direction
LOSA6210	4-40 x 3/8 Flat Head Socket	Losi 4-40 x 3/8 Flachkopfschrauben	Vis tête fraisée 4-40 x 3/8 (10)
LOSA6221	4-40 x 5/8" Cap Screws	Losi 4-40 x 5/8 Zylinderkopfschrauben	Vis chc 4-40 x 5/8 (6)
LOSA6227	Hardened Setscrews, 4-40	Losi Madenschrauben gehärtet 4-40	Vis sans tête 4-40 (10)
LOSA6229	4-40 x 3/8 Button Head Screws	Losi 4-40 x 3/8 Rundkopfschrauben	Vis à tête bombée 4-40x3/8
LOSA6232	Socket Head 2-56 x 1/4	Socket Head 2-56 x 1/4	Vis CHC 2-56 x 1/4
LOSA6234	Button Head Screw, 4-40x1/4	Losi Rundkopfschrauben/4-40x1/4	Vis à tête bombée 4-40x1/4

Part #	English	Deutsch	Français
LOSA6246	2-56 x 5/8 Caphead Screw (8)	Losi 2-56 x 5/8 Zylinderkopfschrauben (8)	Vis chc 5-56 x 5/8 vis (8)
LOSA6256	4-40 x 1/2 Button Head Cap Screw (6)	Losi 4-40 x 1/2 Rundkopfschrauben (6)	Vis tête bombée 4-40 x 1/2 (6)
LOSA6270	5-40 x 3/8" Flat Head Screws (10)	Losi 5-40 x 3/8 Flachkopfschrauben (10)	Vis à tête fraisée 5-40 x 3/8 (10)
LOSA6277	5-40 x 3/8" BH Screws (8)	Losi 5-40 x 3/8 Rundkopfschrauben (8)	Vis tête bombée 5-40 x 3/8 (8)
LOSA6306	4-40 Aluminum Mini-Nuts (10)	Losi 4-40 Aluminium Mini-Muttern (10)	Mini écrou frein 4-40 (10)
LOSA6350	#4 and 1/8" Hardened Washers	Losi Unterlegscheiben #4 and 1/8 gehärtet	Rondelles #4 et 1/8
LOSA6937	5x10mm Shielded Ball Bearing(2)	Losi 5x10mm Shielded Kugellager gekapselt(2)	5x10mm Cuscinetti a sfera sigillati in gomma (2)
LOSA9168	Throttle/Brake Link Set: 8B 2.0	Losi 8B 2.0: Brems u. Gasgestänge Set	8B 2.0 - Tringlerie gaz/frein
LOS241008	Radio Tray, Gasoline: 8IGHT/T RTR	Losi 8IGHT/T RTR: Radioplatte	Platine radio, thermique: 8IGHT/T RTR
DYNE0548	CDI Unit: 31	Dynamite .31: Zündung	Système d'allumage à condensateur (CDI): .31
DYNR0105	On/Off Electronic Switch	On/Off Electronic Switch	Interrupteur électronique On/Off
LOSA99033	Servo Arm, Aluminum: Hitec	Losi Servo Arm/ Aluminium: Hitec	Bras de servo en aluminium Hitec
LOSA99041	Metal Servo Arm Insert, 23 Spline, JR (2)	Losi Metall Servohorneinsatz/ 23 Spline/ JR (2)	Insert 23s JR en métal pour bras de servo (2)
SPMS601H	SPMS601H Extra Hight Torque Hybrid Servo	Spektrum Extra High Torque Hybrid Servo	Servo Hybrid, couple très élevé SPMS601H
SPMS6100	S6100 High Voltage Surface Servo - Torque	S6100 High Voltage Servo Oberfläche - Drehmoment	S6100 haute tension Surface Servo - Couple
TLR1555	Servo Horn, 23T, Aluminum: 22	TLR Servohorn/ 23T/ Aluminium: 22	Palonnier de servo, Aluminium, 23D: 22
TLR4402	Turnbuckle & Ballcaps, GenIII Radio Tray: 8B/T	TLR Anlenkung und Kugelpfannen Radio Tray GenIII : 8B/T	8B/8T Generation III -Chappes et biellettes de platine radio
TLR4403	J Nut, Gen III Radio Tray (2): 8B/T	TLR Anlenkung und Kugelpfannen Radio Tray GenIII : 8B/T	8B/8T Generation III -Fixations J (2)
TLR4406	Throttle Tri-Horn, Gen III Radio Tray: 8B/T	TLR 8B/T Tri Servohorn für Radioplatte Gen III	8B/T - Palonnier triple gaz-frein
TLR6028	Ball Stud, Short Neck, 5mm (2)	TLR Kugelkopf mit Gewinde kurzen Hals, 5mm (2)	Rotule courte épaulée, 5mm (2)
TLR242005	Brake Caliper Springs (4): 8B 3.0	TLR 8ight 3.0 Druckfeder für Bremsplatten (4)	8B 3.0 - Ressorts de mâchoires de freins (4)

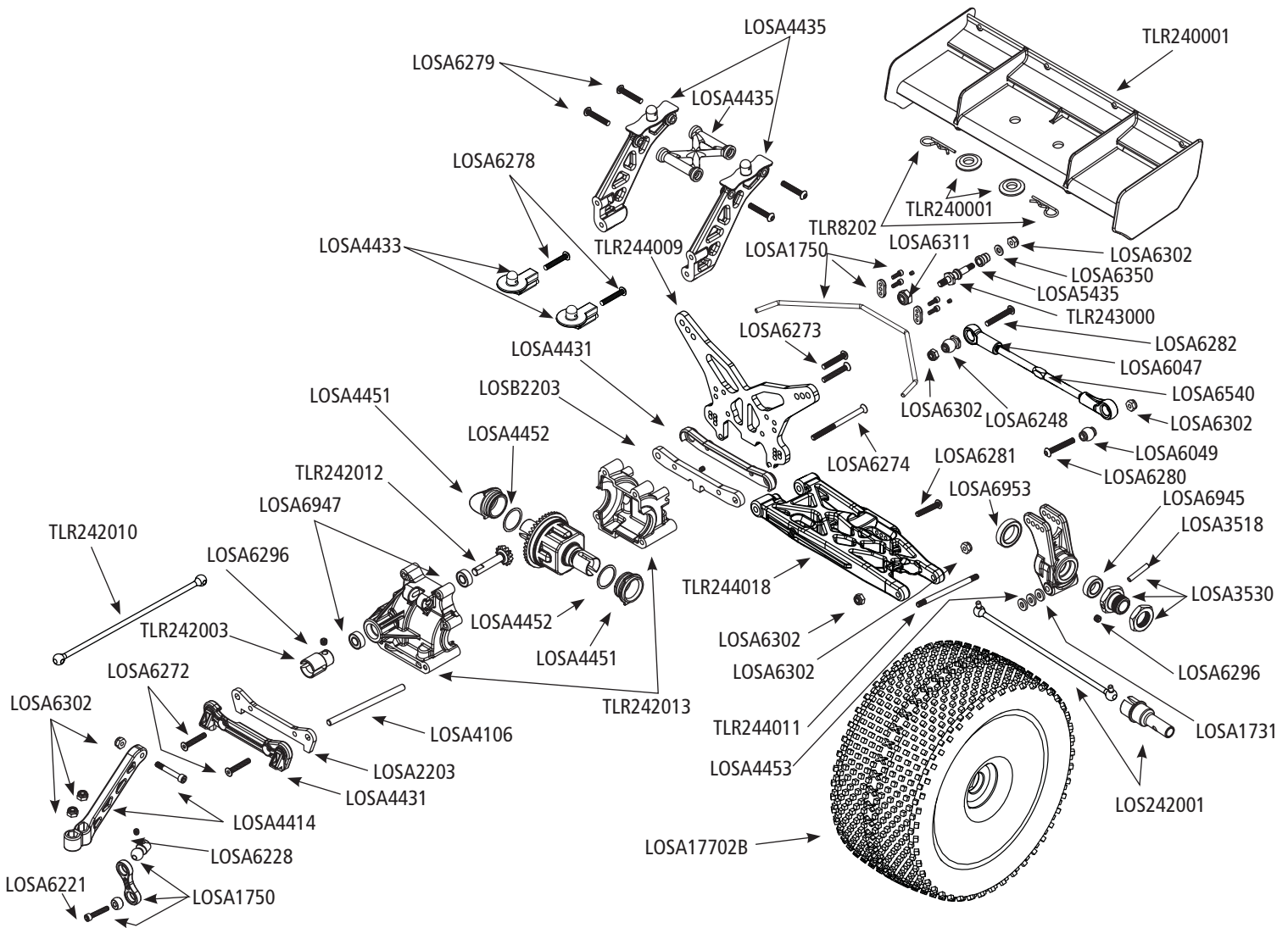

Part #	English	Deutsch	Français
LOSA1731	Rear Hub Carriers: 8B 2.0	Losi 8B 2.0: Radträger hinten	8B 2.0 - Fusées arrière
LOSA1750	Sway Bar Set: 8B,8T	Losi 8B,8T: Stabilisator Set	8B/8T - Jeu de barres anti-roulis (6) + rotules et chapes
LOSA17702B	1/8 XTT TruggyTire,BI,Mntd,w/Yel Whl, 0 Offset (2)	1/8 XTT TruggyTire,BI,Mntd,w/Yel Whl, 0 Offset 2.	1/8 XTT TruggyTire,BI,mural,w/Yel Whl, 0 Oeedéfinir (2)
LOSA3508	Front/Rear Differential Pinion Gear, 13T: 8B	Losi 8B: 13 T Ritzel F/H Diff.	8B - Pignon d'attaque av./arr. de différentiel
LOSA3518	Drive Pin Set: 8B/8T	Losi 8B/8T Mitnehmerstift 8B/8T	8B/8T - Set de diverses goupilles
LOSA3530	Wheel Hexes (Pr) Hard Anodized: 8B,8T	Losi 8B /8T:Radmitnehmer (Pr) gehärtet	8B/8T - Hexagone de jantes anodisé dur (2)
LOSA4414	Rear Chassis Brace: 8B,8T	Losi Chassishalter hinten : 8B,8T	8B/8T - Renfort de châssis arr.
LOSA4431	Hinge Pin Brace Cover Set: 8B, 8T	Losi Losi Hinge Pin Brace Cover Set: 8B/ 8T	Jeux de capots de traverses d'axe de suspension : 8B, 8T
LOSA4433	Body Posts: 8T 2.0	Karosserie Halte: 8T 2.0	8T 2.0 Plots de carrosseries
LOSA4435	Wing Mount Set: 8B, 8T	Losi: Halter Flügel: 8B,8T	8B/8T - Support d'aile complet
LOSA4451	Rear Gear Box Locking Inserts: 8B 2.0	Losi Einsätze Getriebebox 8B 2.	Inserts de verrouillage de carter de transmission: 8B 2.0
LOSA4452	Gear Box Shims (20): 8B 2.0	Losi Unterlegscheiben Getriebebox (B 2.0	8B 2.0 - Rondelles de calage
LOSA4453	Chassis Spacer/Cap Set: 8B 2.0	Losi Distanz und Befestigungs Set: 8B 2.0	8B 2.0 - Diverses entretoises en plastique
LOSA5435	15mm Shock Ends, Cups, Bushing: 8B 2.0	Kugelpfanne, Kugel, Buchsen und Federteller für 15mm Stoßdämpfer: 8B 2.0	8B 2.0 - Chapes et coupelles d'amortisseurs 15mm.
LOSA6047	5mm Rod End Set: 8B, 8T	Losi 5mm Kugelpfannen Set: 8B/ 8T	8B/8T - Chapes 5mm (8)
LOSA6048	Suspension Balls 8.8mm Flanged: 8B,8T	Losi Kugelpfopf m. Flansch 8.8mm: 8B,8T	8B/8T - Rotules épaulées 8.8mm (4)
LOSA6049	Suspension Balls 8.8mm: 8B,8T	Losi Kugelpfopf m. Flansch: 8B,8T	8B/8T - Rotules 8.8mm (4)
LOSA6221	4-40 x 5/8" Cap Screws	Losi 4-40 x 5/8 Zylinderkopfschrauben	Vis chc 4-40 x 5/8 (6)
LOSA6228	Hardened Setscrews,5-40	Losi Madenschrauben gehärtet 5-40	Vis sans tête 5-40 (10)
LOSA6272	5-40 x 3/4" FH Screws (10)	Losi 5-40 x 3/4 Flachkopfschrauben (10)	Vis à tête fraisée5-40 x 3/4 (10)
LOSA6273	5-40 x 7/8" FH Screws (4)	Losi 5-40 x 7/8 Flachkopfschrauben (4)	Vis à tête fraisée 5-40 x 7/8 (10)
LOSA6274	5-40 x 1 7/8" FH Screws (2)	Losi 5-40 x 1 7/8 Flachkopfschrauben (2)	Vis à tête fraisée longues 5-40 x 1 7/8 (2)
LOSA6278	5-40 x 1/2" BH Screws (8)	Losi 5-40 x 1/2 Rundkopfschrauben (8)	Vis tête bombée 5-40 x 1/2 (8)
LOSA6279	5-40 x 3/4" BH Screws (8)	Losi 5-40 x 3/4 Rundkopfschrauben (8)	Vis tête bombée 5-40 x 3/4 (8)
LOSA6280	5-40 x 1" BH Screws (4)	Losi 5-40 x 1 Rundkopfschrauben (4)	Vis tête bombée 5-40 x 1 (4)
LOSA6281	5-40 x 20mm Button Head Screws (10)	Losi 5-40 x 20mm Rundkopfschrauben (10)	Vis tête bombée 5-40 x 20mm (10)
LOSA6282	5-40 x 7/8" BH Screws	Losi 5-40 x 7/8 Rundkopfschrauben	Vis tête bombée 5-40 x 7/8
LOSA6296	8-32 x 1/8 Flat Point Setscrew-8	Losi 8-32 x 1/8 Madenschraube-8	Vis pointeau bout plat 8-32 x 1/8 (8)
LOSA6302	5-40 Locking Nuts,Steel	Losi Stopmmutter 5-40 Stahl (4)	Ecrou Frein acier 5-40 (4)
LOS242001	Rear Dogbone & Axle Set: 8T 3.0	TLR 8ight-T 3.0 Antriebsknochen und Rad	8T 3.0 - Tige + axe de cardan arrière
LOSA6311	8-32 Steel Lock Nuts (10)	Losi 8-32 Stahl Stopmutter (10)	8-32 acier Nylstop (10)
LOSA6350	#4 and 1/8" Hardened Washers	Losi Unterlegscheiben #4 and 1/8 gehärtet	Rondelles #4 et 1/8
LOSA6545	Turnbuckles, 5 x 115mm with Ends	Losi 8: Gewindestift L/R 5mmx60mm	8B - Bielles 5mmx 60mm avec rotules
LOSA6945	8x14x4 Rubber Sealed Ball Bearing (4)	Losi 8x14x4 Kugellager gekapselt (4)	Roulements étanches 8x14x4 (4)
LOSA6947	5x11x4 Rubber Sealed Ball Bearing (4)	Losi 5x11x4 Kugellager gekapselt (4)	Roulements étanches 5x11x4 (4)
LOSA6953	1/2 x 3/4 Rubber Sealed Ball Bearing	Losi 1/2 x 3/4 Rubber Sealed Kugellager	Roulements étanches 1/2 x 3/4 (2)
LOSB2203	Hinge Pin Brace Set: 8RTR	Losi Hinge Pin Brace Set: 8RTR	8RTR Set de renforts de cales
LOSB4106	Hinge Pin Set: 8RTR	Losi Hinge Pin Set: 8RTR	8 RTR axes de suspension
TLR240001	Wing, Black 8IGHT Buggy 3.0	TLR 8ight 3.0: Spoiler Schwarz	8B 3.0 - Aileron noir
TLR242002	Center Dogbone: 8B 3.0 (rear), 8E 3.0 (front)	TLR 8ight 3.0 Antriebsknochen Mitte/Hinten	8B 3.0 - Cardan central arrière
TLR242003	Coupler Outdrive: 8IGHT Buggy 3.0	TLR 8ight 3.0 :Kupplungsstück für Antriebsklaue (2)	8B 3.0 - Noix d'accouplement de cardan (2)
TLR242010	Center Dog Bone Set, Front and Rear: 8T 3.0	Antriebsknochenset v/h: 8T 3.0	3.0 8T 3.0 - Cardan central av et arr
TLR242012	Rear Ring and Pinion Gear Set: 8T 3.0	Kegelrad hinten u. Ritzelset: 8T 3.0	8T 3.0 - Couronne et pignon de diff arr
TLR242013	Front and Rear Gear Box Set: All 8IGHT	TLR Getriebebox v/h Set: alle 22/xxx	8IGHT - Boîtier de différentiel, av./arr.
TLR243000	Shock Stand-off Set (2): 8B 3.0	TLR 8ight 3.0 Stehbolzen für Dämpferbefestigung (2)	8B 3.0 - Entretoises d'amortisseurs (2)
TLR244009	Rear Shock Tower: 8B 3.0	TLR 8ight 3.0: Dämpferbrücke hinten	8B 3.0 - Support d'amortisseurs arrière
TLR244012	Outer Hinge Pins, 3.5mm (2): 8B 3.0	TLR 8ight 3.0: Hinge Pins Aussen 3,5mm (2)	8B 3.0 - Axes de suspension extérieurs, 3.5mm (2)
TLR244018	Rear Suspension Arm Set: 8B 3.0	TLR 8ight 3.0: Querlenkersatz Hinten	8B 3.0 - Jeu de bras de suspension arrière
TLR8202	Body Clips, Black (12): 22/22-4	TLR Karosseriekammern Schwarz: 22	Clips de carrosserie noir (12)

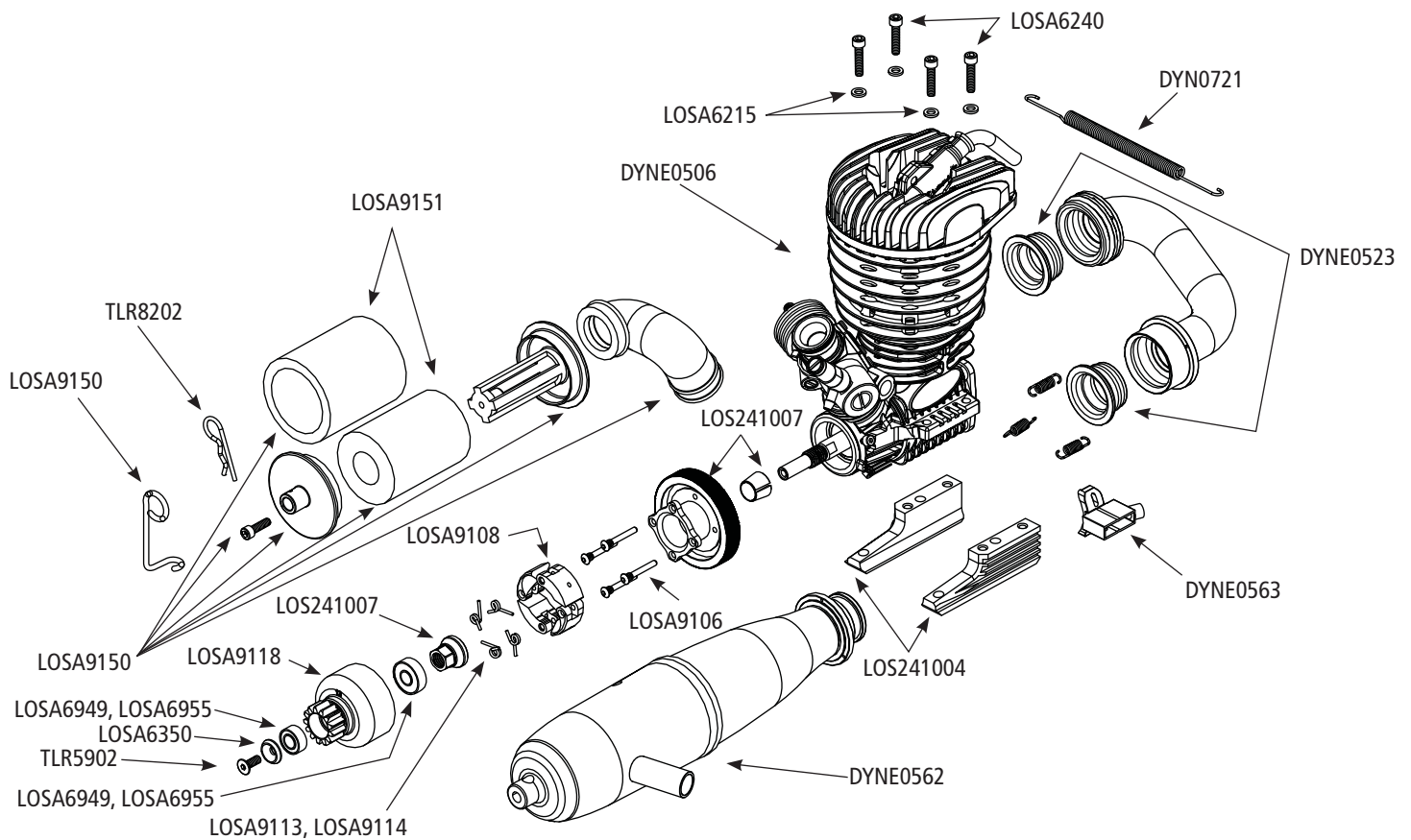

Part #	English	Deutsch	Français
LOSA6215	#4 Narrow Washers (10)	Losi Unterlegscheibe #4	Rondelles étroites #4 (10)
LOSA6240	5-40 x 1/2 Caphead Screw (8)	Losi 5-40 x 1/2 Zylinderkopfschrauben (8)	Vis chc 5-40 x 1/2 vis (8)
LOSA6350	#4 and 1/8" Hardened Washers	Losi Unterlegscheiben #4 and 1/8 gehärtet	Rondelles #4 et 1/8
LOSA6949	Clutch Bearing Set: 8B,8T	Losi 8B,8T: Kupplungslager Set	8B/8T - Roulements de cloche (2)
LOSA6954	5 x 10mm HD Clutch Bearings (2): 8B/8T	Losi 5 x 10mm HD Kupplungslager (2): 8B/8T	Roulements de cloche renforcé 5 x 10mm (2): 8B/8T
LOSA6955	5 x 13mm HD Clutch Bearings (2):8B/8T	Losi 5 x 13mm HD Kupplungslager (2):8B/8T	Roulements de cloche renforcé 5 x 13mm (2): 8B/8T
LOSA9106	Clutch Pins & Hardware: 8B 2.0	Losi 8B 2.0: Kupplungsstiftsatz inkl. Zubehör	8B 2.0 - Masselottes d'embrayage allégées en aluminium
LOSA9108	Clutch Shoes, Lightened Aluminum (2): 8B, 8T	Losi 8B/8T: Kupplungsbacken/ Aluminium (2)	8B/8T - Paire de masselottes allégées en alu
LOSA9113	Clutch Springs, Green (4): 8B, 8T	Losi 8B / 8T: Kupplungsfeder mittel, Grün (4)	8B/8T - Ressorts d'embrayage, verts (4)
LOSA9114	Clutch Springs, Gold(4): 8B, 8T	Kupplungsglocke 15T: 8B, 8T	Molle frizione, oro (4): 8B, 8T
LOSA9118	Clutch Bell 15T: 8B, 8T	Losi 8B /8T: Luftfilter Set	8B/8T - Filtre à air complet
LOSA9150	Air Filter Set: 8B, 8T	Losi 8B/8T: Luftfiltereinsatz vorgeölt	8B/8T - Mousses de filtre à air
LOSA9151	Air Filter Foams, Pre-Oiled: 8B, 8T	Losi 8B/8T: Luftfiltereinsatz vorgeölt	8B/8T - Mousses de filtre à air
LOS241004	Engine Mounts, Gasoline: 8IGHT/T RTR	Losi 8IGHT/T RTR: Motorhalter Benziner	Support moteur, thermique: 8IGHT/T RTR
LOS241007	Flywheel, Hardware, Gasoline: 8IGHT/T RTR	Losi 8IGHT/T RTR: Schwungrad m. Zbh.	Volant moteur, accessoires, thermique 8IGHT/T RTR
TLR5902	Button Head Screws, M3 x 8mm (10)	TLR Rundkopfschraube, M3 x 8mm (10)	Vis tête bombée, M3 x 8mm (10)
TLR8202	Body Clips, Black (12): 22/22-4	TLR Karosserieklemmern Schwarz: 22	Clips de carrosserie noir (12)
DYNE0506	.31 Ci Gas Engine (5.1cc) with CDI: 8IGHT	Dynamite .31 Benzinmotor (5.1cc) W/CDI: 8B, 8T	Moteur thermique 5.1 cc avec CDI: 8IGHT
DYNE0523	Exhaust Manifold Gasket: .31	Dynamite .31: Krümmerdichtung	Moteur .31 - Joint d'échappement
DYNE0562	Tuned Pipe Set: 31 8B/8T	Dynamite: Tuning Schalldämpfer.31 8B 8T	Kit de pot d'échappement: 31 8B/8T
DYNE0563	Ignition Sensor Set: .31 8B/8T	Ignition Set: .31 8B, 8T	Kit d'allumage : .31 8B, 8T
DYN0721	Exhaust Manifold Spring	Exhaust Manifold Spring	Ressort de coude d'échappement

Front Shock Assembly
Vorderer Stoßdämpfer
Montage
Assemblage
amortisseur avant

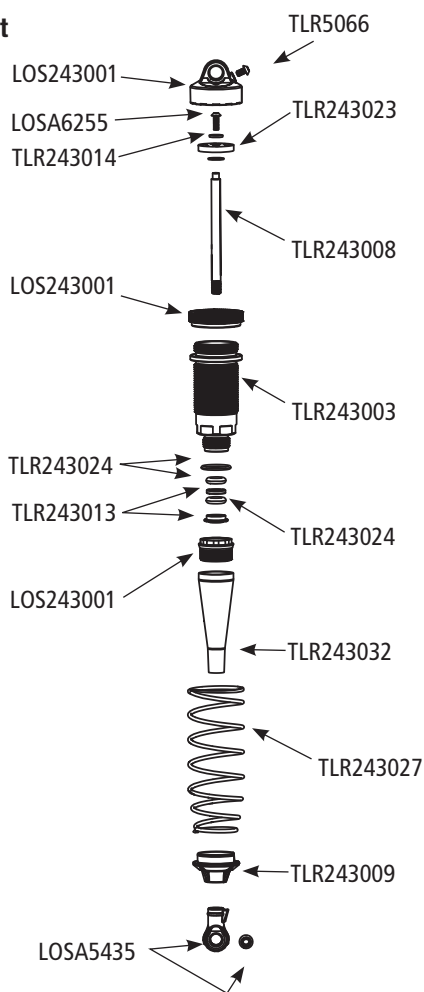

Rear Shock Assembly
Hintere Stoßdämpfer
Montage
Assemblage
amortisseur arrière

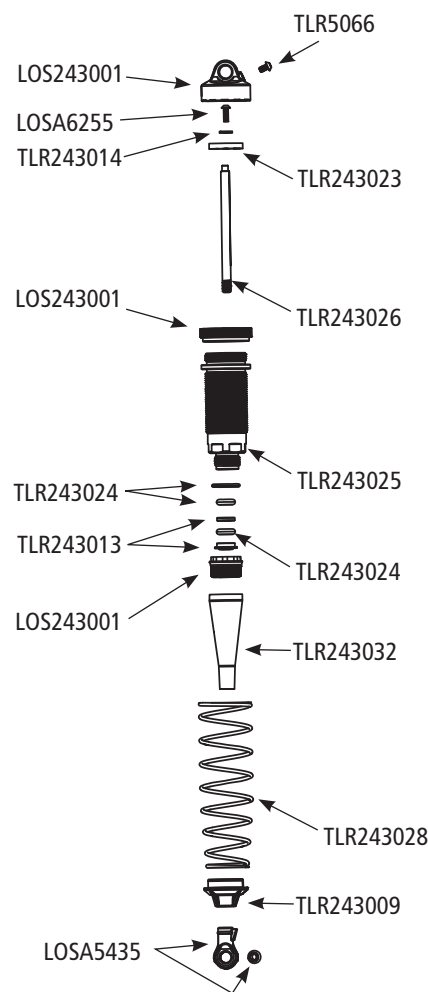

Part #	English	Deutsch	Français
LOSA5435	15mm Shock Ends, Cups, Bushing: 8B 2.0	Kugelpfanne, Kugel, Buchsen und Federteller für 15mm Stoßdämpfer: 8B 2.0	8B 2.0 - Chapes et coupelles d'amortisseurs 15mm.
LOSA6255	2-56 x 1/4" Button Head Screws (10)	Losi 2-56 x 1/4 Rundkopfschrauben (10)	Vis tête bombée 2-56 x 1/4 (10)
LOS243001	Shock Plastics: 8 RTR	Losi 8IGHT-E : Stoßdämpfer Kunststoff	8B 3.0 RTR - Bouchons d'amortisseurs, plastique
TLR243003	6mm Shock Body Set (2): 8B 3.0 Rear, 8T 3.0 Front	TLR 8ight 3.0: 16mm Dämpfergehäuse Hinten (2)	8B 3.0 - Corps d'amortisseurs arrière (2)
TLR243008	6mm Shock Shaft, 4mm x 59.5mm, TiCn Reart: 8B 3.0	TLR 8ight 3.0 Kolbenstange Hinten 4mm x 59.5mm TiCn	8B 3.0 - Tige d'amortisseur arrière Ti-Cn 4x59,5mm (1)
TLR243009	Shock Cup (4): 8IGHT 3.0	TLR 8ight 3.0: Kugelpfanne für Dämpfer	8B 3.0 - Coupelle d'amortisseurs (4)
TLR243013	Shock Guide & Bushing (8): 8B 3.0	TLR 8ight 3.0 Dämpferschutz und Hülsen (8)	8B 3.0 - Palier et guide d'amortisseur (4)
TLR243023	16mm Shock Piston, 1.4/1.5 5 Hole	TLR 8IGHT E 3.0 16mm Kolbenplatte 1.4/1.5	8B 3.0 - Piston d'amortisseur usiné 1.4/1.5mm, diam 16mm (2)
TLR243025	16mm Shock Body Set, Rear (2): 8IGHT-T 3.0	8T 3.0 - Corps d'amortisseurs arrière (2)	16mm set corpo ammort., RR (2): 8T 3.0
TLR243026	16mm Shock Shaft, 4mm x 67mm, TiCn, Rear: 8IGHT-T 3.0	8T 3.0 - Tige d'amortisseur arrière Ti-Cn (1)	16mm albero ammort., Ti-Cn, RR: 8T 3.0
TLR243027	16mm Front Shock Spring Set (3 pr.): 8IGHT-T 3.0	8T 3.0 - Ressort d'amortisseurs avant 16mm, 3 paires	16mm set molla ammort. ant. 3pr: 8T 3.0
TLR243028	16mm Rear Shock Spring Set (3 pr.): 8IGHT-T 3.0	8T 3.0 - Ressort d'amortisseurs arrière 16mm, 3 paires	16mm set molla ammort. post. 3pr: 8T 3.0
TLR243032	16mm Shock Boot Set (8): 8T 3.0	16mm Stoßdämpfermanschetten Set (8): 8B/E 3.0	Jeux de soufflets d'amortisseur 16mm (8): 8B/E 3.0
TLR5066	Bleeder Shock Cap Screw & Washers(4): 22/22T	TLR Bleeder Shock Cap Screws & Washers (4): 22	Vis et rondelles de purge de bouchon d'amortisseur (4) : 22/22T
TLR99059	8IGHT/8IGHT-T 2.0/3.0 Starter Box	TLR 8IGHT/8IGHT-T 2.0 Starter Box	8B/8T 2.0/3.0 - Banc de démarrage

Optional Parts • Diverse teile • Pieces optionnelles • Parti Opzionali

Part #	English	Deutsch	Français
DYN2517	Body Scissors: Curved/Straight	Dynamite Lexanschere halb gebogen	Ciseaux à lexan : courbé/droit
DYN9905	Dynamite Surface Pit Mat	Dynamite Surface Pit Matte	Tapis de stand Dynamite
DYNT2000	Machined Nut Driver Set(4pc)US	Dynamite Steckschlüssel Set (4tlg) Zoll	Jeux de tournevis à douille US usinés (4)
DYNT2020	Machined Hex Driver Set (4) US	Dynamite Inbusschlüssel Set (4tlg) Zoll	Jeux de tournevis hexagonaux US usinés (4)
DYNT2113	Suspension Arm Reamer 4mm	Dynamite Querlenkerreibahle 4mm	Alésoir 4mm pour bras de suspension
LOSA1732	Rear Hub Carriers, Aluminium:	Losi Radträger Hinten Aluminium: 8B/ 8T 2.0	8B/8T 2.0 - Fusées arrières en aluminium
LOSA1751	Sway Bar Set: 8B 2.0	Losi 8B 2.0: Stabilisator Set	8B 2.0 - Set de barre anti-roulis
LOSA1754	Adjustable Front Hinge Pin Brace w/Inserts: 8B/8T	Losi 8B/8T: Querlenkerhalter vorne einstellbar mit Einsätze Aluminium	8B/8T - Cales de pincement avant réglable en aluminium avec inserts
LOSA1755	Adjustable Rear Hinge Pin Brace w/Inserts: 8B/8T	Losi Querlenkerhalter Hinten einstellbar mit Einsätze: 8B/8T	8B/8T - Cales de pincement arrière réglable en aluminium avec inserts
LOSA1756	Adjustable Hinge Pin Brace Inserts: 8B/8T	Losi 8B/8T: Einsätze für Querlenkerhalter	8B/8T - Jeu d'inserts pour cales de pincement
LOSA1759	LRC Adj Rear Hinge Pin Brace w/Inserts: 8B/T 2.0	Losi 8B/T2.0: Querlenkerhalter hinten einstellbar m. Einsätze LRC	8B/8T/8B 2.0/8 EU - Cales de pincement réglables avec inserts
LOSA17701B	XXT Pre-Mounted 1/8 Truggy Tires/White Wheels(2)	VAST XXT Pre-Mounted 1/8 Truggy Reifen/weiße Felgen(2)	XXT Pre-Mounted 1/8 Truggy pneus/roues blanc(2)
LOSA3515	Center Differential 50T Spur Gear: 8B,8T	Hauptzahnrad 50Z: 8B,8T	8B/8T - Couronne 50T différentiel central
LOSA3517	Center Differential 47T Spur Gear: 8B,8T	Losi 8 B,8 :Hauptzahnrad 47Z	8B/8T - Couronne de diff central 47T
LOSA3530	Wheel Hexes (Pr) Hard Anodized: 8B,8T	Losi 8B /8T:Radmitnehmer (Pr) gehärtet	8B/8T - Hexagone de jantes anodisé dur (2)
LOSA3532	Wheel Hexes (4) + 2mm Wider: 8B,8T	Losi 8B/8T : Radmitnehmer (4) + 2mm breiter	8B/8T - Hexagones de roues largeur +2mm (4)
LOSA3533	Wheel Hexes (4) + 1/2" Wider: 8B, 8T	Losi Radmitnehmeres (4) + 1/2 Dick: 8B/ 8T	Hexagones de roue (4) + 12.7mm de largeur: 8B, 8T
LOSA3536	Center R CV Driveshaft Assemby: 8B 2.0	Losi 8B 2.0: Antriebswelle Mitte/Hinten inkl. Zubehör	Cardan central arrière CVD complet
LOSA3537	Grease Boot: 8B 2.0	Losi Staubschutzmanschette: 8B 2.0	Soufflet à graisse: 8B 2.0
LOSA3551	Center Differential 46T Spur Gear: 8B,8T	Losi 8B/8T: Hauptzahnrad 46Z	8B/8T - Couronne de diff central 46T
LOSA3553	Front/Rear HD Lightened Outdrive Set (2): 8B, 8T	Losi 8B, 8T: Antriebsklauen Set Leicht (2)	8B/8T - Noix de cardan allégées HD (2)
LOSA3554	Center HD Lightened Differential Outdrives (2)	Losi Antriebsklauen für Mitteldiff, Leichtbau (2)	Noix de cardans allégées HD (2)
LOSA3556	Center Diff 48T Spur Gear, Lightweight: 8B/8T	Losi Hauptzahnrad 48Z, Leichtbau: 8B/8T	8B/8T -Couronne allégée 48T pour différentiel central
LOSA3587	Front Center Universal Driveshaft: 8 2.0	Losi 8 2.0: Antriebswelle vorne	8B 2.0 - Cardan central avant
LOSA3600	Front SmartDiff: 8B 2.0	Losi 8B 2.0 Front SmartDiff.	8B 2.0 - Smartdiff avant
LOSA3601	Center SmartDiff: 8B 2.0	Losi 8B 2.0: SmartDiff Mitte	8B 2.0 - Smartdiff central
LOSA4416	Aluminum Front Chassis Brace: 8B, 8T	Losi 8B,8T : Chassis Strebe vorne Aluminium	8B/8T - Renfort de châssis avant en aluminium
LOSA4417	Aluminum Rear Chassis Brace: 8B, 8T	Losi 8B, 8T: Chassis Strebe hinten Aluminium	8B/8T - Renfort de châssis arrière en aluminium
LOSA4440	Front Top Brace, Aluminum: 8B, 8T	Losi Chassishalter vorne Alu. : 8B,8T	8B/8T - Renfort de châssis supérieur avant en aluminium
LOSA4444	Split Center Diff Mount, Aluminum: 8B/8T 2.0	TLR 8B/8T 2.0 : teilbarer Diffblock, Alu	8B/8T 2.0 - Support de différentiel central en aluminium
LOSA4454	Rear Gearbox Bearing Inserts, Aluminum 8B/8T 2.0	TLR Lagerschalen Hinten, Aluminum 8B/8T 2.0	8B/8T 2.0 - Inserts de Roulements de diff arr. en aluminium + cales
LOSA5421	15mm Shock Caps Bottom (2): 8B 8T	Endkappen Unter, für 15mm Stoßdämpfer: 8B, 8T	8B/8T - Bouchons inférieurs 15mm (2)
LOSA6140	8IGHT Screw/Nut Assortment Box	8IGHT Schrauben und Muttern im Sortimentskasten	8B - Boite d'assortiment de vis et d'écrous
LOSA6929	8IGHT/T Bearing Box with Bearings	Losi: 8IGHT/T Kugellagersatz im Sortimentskasten	8B/8T - Boite à roulements avec roulements
LOSA8131	8IGHT Wing, White: 8B,8T	Losi 8B, 8T: Spoiler, Weiß	8B/8T - Aileron blanc
LOSA9119	Clutch Bell 16T: 8B, 8T	Kupplungsglocke 16T: 8B, 8T	Cloche d'embrayage 16D: 8B, 8T
LOSA9121	Clutch Bell 17T: 8B, 8T	Kupplungsglocke 17T: 8B, 8T	Cloche d'embrayage 17D: 8B, 8T
LOSA9122	Clutch Bell 18T: 8B, 8T	Kupplungsglocke 18T: 8B, 8T	Cloche d'embrayage 18D: 8B, 8T
LOSA99030	Servo Arm, Aluminum: JR	Losi Servo Arm/ Aluminium: JR	Bras de servo en aluminium JR
LOSA99031	Servo Arm, Aluminum: KO/AIR	Losi Servo Arm/ Aluminium: KO/AIR	Bras de servo en aluminium KO/Airtronics
LOSA99032	Servo Arm, Aluminum: FUT	Losi Servo Arm/ Aluminium: FUT	Bras de servo en aluminium Futaba
LOSA99033	Servo Arm, Aluminum: HITEC	Losi Servo Arm/ Aluminium: Hitec	Bras de servo en aluminium Hitec
LOSA99040	Metal Servo Arm Insert, 23S Spline, Airtronics (2)	Losi Metall Servohorneinsatz/ 23S Spline/ Airtronics (2)	Insert 23s Airtronics en métal pour bras de servo (2)
LOSA99042	Metal Servo Arm Insert, 24 Spline, Hitec (2)	Losi Metall Servohorneinsatz/ 24 Spline/ Hitec (2)	Insert 24s Hitec en métal pour bras de servo (2)
LOSA99043	Metal Servo Arm Insert, 25 Spline, Futaba (2)	Losi Metall Servohorneinsatz/ 25 Spline/ Futaba (2)	Insert 25s Futaba en métal pour bras de servo (2)
DYN2950	8-in-1 Locking Hex Wrench Kit	Dynamite Multi-Norm Inbusschlüssel Set	Set de tournevis BTR
LOSA99166	Losi Exhaust Spring Tool	Krümmfeder Werkzeug	Outil Losi pour ressort de résonateur

Part #	English	Deutsch	Français
LOSA99167	Losi Tuning Screwdriver	Losi Schraubendreher	Tournevis de réglage Losi
LOSA99172	Camber Gauge	LOSI Sturzlehre	Jauge de carrossage
LOSA99173	Ride Height Gauge	LOSI Höhenmesser	Cale de garde au sol
LOSA99174	Car Stand: 8IGHT/T	Losi 8 /T Fahrzeugständer	8B/8T - Support de stand
LOSA99176	Precision Tire Balancer with Balancing Clay	Losi Präzisionsreifenwuchtgerät	Équilibreur de roue de précision avec pâte d'équilibrage
LOSA99177	Tire Balancing Clay, 3oz, 85g	Losi Reifenwuchtton (85g)	Patte d'équilibrage, 85grs
LOSA99201	Self-Stick Chassis Weight, 3 oz	Selbstklebe-Chassisgewichte 3 oz	Lest de châssis autoadhésif, 85grs
LOSB3528	Heavy-Duty Differential Case: 8, 8T, LST2, XXL/2	Losi 8, 8T, LST2: Heavy-Duty Differenzial Gehäuse	8B/8T/LST2 - Corps de différentiel renforcé
LOSB4604	17mm Wheel Wrench Anodized Alum: LST2, MUG, 8B, 8T	Losi LST2/ MUG/ 8B/ 8T: 17mm Radschlüssel Alu	LST2/8B/8T - Clé de roue 17mm en aluminium anodisé
TLR240002	Wing, White 8IGHT 3.0	TLR 8ight 3.0 Spoiler Weiß	8B 3.0 - Aileron blanc
TLR240003	Wickerbill Set (2): 8IGHT Buggy 3.0	TLR 8ight 3.0 Abrisskante Set (2)	8B 3.0 - Jeu de rajouts d'aileron (2)
TLR242003	Coupler Outdrive: 8IGHT Buggy 3.0	TLR 8ight 3.0 :Kupplungsstück für Antriebsklaue (2)	8B 3.0 - Noix d'accouplement de cardan(2)
TLR242004	Wheel Hexes, +1mm Wider (4): 8IGHT Buggy 3.0	TLR 8ight 3.0 Radmitnehmer 1mm verbreitert (4)	8B 3.0 - Hexagones +1mm (4)
TLR243001	16mm Shock Cap (2): 8B 3.0	TLR 8ight 3.0 16mm Dämpferkappe (2)	8B 3.0 - Bouchons d'amortisseurs (2)
TLR243004	16mm Shock Bladders (4): 8B 3.0	TLR 8ight 3.0 16mm Dämpfermembrane (4)	8B 3.0 - Membranes d'amortisseurs (4)
TLR243005	16mm Shock Nuts & O-rings: 8B 3.0	TLR 8ight 3.0 16mm Dämpferkappe (2)	8B 3.0 - Bagues d'amortisseurs et joints toriques (4)
TLR243006	16mm Shock Nut O-rings (4): 8B 3.0	TLR 8ight 3.0 16mm Dämpfermembrane (4)	8B 3.0 - Ecrou et joints toriques (4)
TLR243010	16mm Shock Piston, 1.2mm (2): 8B 3.0	TLR 8ight 3.0: 16mm Kolbenplatte 1.2mm (2)	8B 3.0 - Piston d'amortisseur 1.2mm, diam 16mm (2)
TLR243011	16mm Shock Piston, 1.3mm (2): 8B 3.0	TLR 8ight 3.0: 16mm Kolbenplatte 1.3mm (2)	8B 3.0 - Piston d'amortisseur, 1.3mm (2)
TLR243012	16mm Shock Piston, Split (2): 8B 3.1	TLR 8ight 3.0: 16mm Kolbenplatte Split (2)	8B 3.0 - Piston d'amortisseur, 1.3/1.2mm (2)
TLR243013	Shock Guide & Bushing (8): 8B 3.0	TLR 8ight 3.0 Dämpferschutz und Hülsen (8)	8B 3.0 - Palier et guide d'amortisseur (4)
TLR243016	16mm Front Shock Spring, 4.8 Rate, Green (2): 8B 3.0	TLR 8ight 3.0 : Federsatz Grün 4.8 Vorne (2)	8B 3.0 - Ressort d'amortisseur avant, dureté 4.8, vert (2)
TLR243017	16mm Front Shock Spring, 5.0 Rate, Black (2): 8B 3.0	TLR 8ight 3.0 : Federsatz Schwarz 5.0 Vorne (2)	8B 3.0 - Ressort d'amortisseurs avant 16mm, dureté 5.0, noir (2)
TLR243018	16mm Rear Shock Spring, 3.4 Rate, Red (2): 8B 3.0	TLR 8ight 3.0 : Federsatz Rot 3.4 Hinten (2)	8B 3.0 - Ressort d'amortisseurs arrière 16mm, dureté 3.4, rouge (2)
TLR243019	16mm Rear Shock Spring, 3.6 Rate, Silver (2): 8B 3.0	TLR 8ight 3.0 Federsatz Silber 3.6 Hinten (2)	8B 3.0 - Ressort d'amortisseur arrière, dureté 3.6, argent (2)
TLR243020	16mm Rear Shock Spring, 3.8 Rate, Green (2): 8B 3.0	TLR 8ight 3.0 : Federsatz Grün 3.8 Hinten (2)	8B 3.0 - Ressort d'amortisseurs arrière 16mm, dureté 3.8, vert (2)
TLR243021	16mm Front Shock Set, Complete: 8B 3.0	TLR 8ight 3.0 Dämpfersatz Vorne	Jeux complet d'amortisseurs avant 16mm : 8B 3.0
TLR243022	16mm Rear Shock Set, Complete: 8B 3.0	TLR 8ight 3.0 Dämpfersatz Hinten	Jeux complet d'amortisseurs arrière 16mm : 8B 3.0
TLR243029	16mm Shk Piston Set, Tapered 1.3mm/Split: 8IGHT 3.0	TLR 8T 3.0 16mm Stoßdämpferkolbenset , Tapered 1.3mm/Split	Jeux de pistons d'amortisseur 16mm, 1.3mm/Split conique: 8IGHT 3.0
TLR243030	16mm Shk Piston Set, Tapered 1.4/1.5mm: 8IGHT-T/E 3.0	TLR 8T 3.0 1,4/1,5 mm Stoßdämpferkolbenset	8T/E 3.0 - Pistons coniques 1.4/1.5mm
TLR244010	Wing Spacer Set, .250 & .500: 8B 3.0	TLR 8ight 3.0: Distanzhülsen für Spoiler .250/.500	8B 3.0 - Entretoises d'aileron, .250 et .500
TLR244021	Servo Saver Top, Aluminum: All 8IGHT/T	TLR Servo Saver Aluminium: alle 8IGHT/T	8B/8T - Bras de sauve-servo en aluminium
TLR246000	Aluminum Spacer, 1mm & 2mm (8)	TLR 8ight 3.0: Aluminium Distanzstück 1mm / 2mm (8)	Entretoises en aluminium, 1 et 2mm (8)
TLR249000	8IGHT 3.0 Logo Sticker Sheet	TLR 8ight 3.0 : Aufklebersatz	8B 3.0 - Plaque de décoration
TLR3500	F/R CV Driveshaft Axles, Aluminum (4): 8B, 8T 2.0	TLR 8B, 8T 2.0 : Radachsen Vorne/Hinten Aluminium	8B/8T 2.0 - Axes de roues en aluminium(4)
TLR3501	Differential Shaft Set, Aluminum (6): 8B, 8T 2.0	TLR 8B, 8T 2.0: Diff Achskreuz, Aluminium	8B/8T 2.0 - Jeu de goupilles de cardan en aluminium (6)
TLR3510	Front Overdrive Gear Set: 8B	TLR 8B: Overdrive Antriebsset Vorne	8B - Prépondérance avant (couronne + pignon d'attaque)
TLR3538B	Covered 17mm Wheel Nuts, Alum, Blue: 8/T 2.0	TLR Radmutter geschlossen 17mm Blau: 8B/8T 2.0	8B/8T 2.0 - Ecrou de roue fermé 17mm en aluminium anodisé noir (4)
TLR3538BL	Covered 17mm Wheel Nuts, Alum, Black: 8/T 2.1	TLR 8B/8T 2.0: Radmutter geschlossen 17mm Schwarz	8B/8T 2.0 - Ecrou de roue fermé 17mm en aluminium anodisé noir (4)
TLR3538R	Covered 17mm Wheel Nuts, Alum, Red: 8/T 2.2	TLR Radmutter geschlossen 17mm Rot: 8B/8T 2.0	8B/8T 2.0 - Ecrou de roue fermé 17mm en aluminium anodisé rouge (4)
TLR5280	Silicone Diff Fluid, 5000CS	Silikon Differentialöl, 5000CS	Graisse silicone pour différentiel, 5000CS
TLR5281	Silicone Diff Fluid, 15,000CS	Silikon Differentialöl 7000 CS	Graisse silicone pour différentiel, 7000CS
TLR74000	Silicone Shock Oil, 15wt, 2oz	TLR Silikon Dämpferöl, 15wt, 2oz	Huile silicone d'amortisseur, 15wt, 60 ml
TLR74001	Silicone Shock Oil, 17.5wt, 2oz	TLR Silikon Dämpferöl, 17.5 wt, 2oz	Huile silicone d'amortisseur, 17.5wt, 60 ml

Part #	English	Deutsch	Français
TLR74002	Silicone Shock Oil, 20wt, 2oz	TLR Silikon Dämpferöl, 20 wt, 2 oz	Huile silicone d'amortisseur, 20wt, 60 ml
TLR74003	Silicone Shock Oil, 22.5wt, 2oz	TLR Silikon Dämpferöl, 22.5wt, 2oz	Huile silicone d'amortisseur, 22.5wt, 60 ml
TLR74005	Silicone Shock Oil, 27.5wt, 2oz	TLR Silikon Dämpferöl, 27.5wt, 2oz	Huile silicone d'amortisseur, 27.5wt, 60 ml
TLR74006	Silicone Shock Oil, 30wt, 2oz	TLR Silikon Dämpferöl, 30wt, 2oz	Huile silicone d'amortisseur, 30wt, 60 ml
TLR74007	Silicone Shock Oil, 32.5wt, 2oz	TLR Silikon Dämpferöl, 32.5 wt, 2 oz	Huile silicone d'amortisseur, 32.5wt, 60 ml
TLR74008	Silicone Shock Oil, 35wt, 2oz	TLR Silikon Dämpferöl, 35wt, 2oz	Huile silicone d'amortisseur, 35wt, 60 ml
TLR74009	Silicone Shock Oil, 37.5wt, 2oz	TLR Silikon Dämpferöl, 37.5wt, 2oz	Huile silicone d'amortisseur, 37.5wt, 60 ml
TLR74010	Silicone Shock Oil, 40wt, 2oz	TLR Silikon Dämpferöl, 40wt, 2oz	Huile silicone d'amortisseur, 40wt, 60 ml
TLR74011	Silicone Shock Oil, 42.5wt, 2oz	TLR Silikon Dämpferöl, 42.5wt, 2oz	Huile silicone d'amortisseur, 42.5wt, 60 ml
TLR74012	Silicone Shock Oil, 45wt, 2oz	TLR Silikon Dämpferöl, 45wt, 2oz	Huile silicone d'amortisseur, 45wt, 60 ml
TLR74013	Silicone Shock Oil, 50wt, 2oz	TLR Silikon Dämpferöl, 50wt, 2oz	Huile silicone d'amortisseur, 50wt, 60 ml
TLR74014	Silicone Shock Oil, 60wt, 2oz	TLR Silikon Dämpferöl, 60wt, 2oz	Huile silicone d'amortisseur, 60wt, 60 ml
TLR74015	Silicone Shock Oil, 70wt, 2oz	TLR Silikon Dämpferöl, 70wt, 2oz	Huile silicone d'amortisseur, 70wt, 60 ml
TLR74016	Silicone Shock Oil, 80wt, 2oz	TLR Silikon Dämpferöl, 80wt, 2oz	Huile silicone d'amortisseur, 80wt, 60 ml
TLR74017	Silicone Shock Oil, 90wt, 2oz	TLR Silikon Dämpferöl, 90wt, 2oz	Huile silicone d'amortisseur, 90wt, 60 ml
TLR74018	Silicone Shock Oil, 100wt, 2oz	TLR Silikon Dämpferöl, 100wt, 2oz	Huile silicone d'amortisseur, 100wt, 60 ml
TLR74019	Shock Oil 6Pk, 17.5,22.5,27.5,32.5,37.5, 42.5 2oz	Shock Oil 6Pk, 17.5, 22.5, 27.5, 32.5, 37.5, 42.5 2oz	Assortiment huile silicone d'amortisseur en 60 ml, 17.5/22.5/27.5/32.5/37.5/42.5
TLR74020	Shock Oil 6Pk, 20,25,30,35,40,45, 2oz	Shock Oil 6Pk, 20,25,30,35,40,45, 2oz	Assortiment huile silicone d'amortisseur en 60 ml, 20/25/30/35/40/45
TLR74021	Shock Oil 6Pk, 50,60,70,80,90,100, 2oz	Shock Oil 6Pk, 50,60,70,80,90,100, 2oz	Assortiment huile silicone d'amortisseur en 60 ml, 50/60/70/80/90/100
TLR74022	Silicone Shock Oil, 25wt, 4oz	TLR Silikon Dämpferöl, 25wt, 4oz	Huile silicone d'amortisseur, 25wt
TLR74023	Silicone Shock Oil, 30wt, 4oz	TLR Silikon Dämpferöl, 30wt, 4oz	Huile silicone d'amortisseur, 30wt
TLR74024	Silicone Shock Oil, 35wt, 4oz	TLR Silikon Dämpferöl, 35wt, 4oz	Huile silicone d'amortisseur, 35wt
TLR74025	Silicone Shock Oil, 40wt, 4oz	TLR Silikon Dämpferöl, 40wt, 4oz	Huile silicone d'amortisseur, 40wt
TLR74026	Silicone Shock Oil, 45wt, 4oz	TLR Silikon Dämpferöl, 45wt, 4oz	Huile silicone d'amortisseur, 45wt
TLR74027	Silicone Shock Oil, 50wt, 4oz	TLR Silikon Dämpferöl, 50wt, 4oz	Huile silicone d'amortisseur, 50wt
TLR76000	Tire Glue, Standard	TLR Reifenkleber Standard	Colle à pneus standard
TLR76001	Tire Glue, Thin	TLR Reifenkleber Dünn	Colle à pneus fine
TLR76002	Off-Road Tire Gluing Kit	TLR Offroad Reifenklebeset	Kit de collage de pneus TT
TLR76004	TLR Lok, Threadlock, Blue	TLR Schraubensicherungslack Blau	Frein filet bleu TLR-Lok
TLR77000	High-Pressure Black Grease, 8cc	TLR High-Pressure Fett Schwarz/8cc	Graisse haute pression noire, 8cc
TLR77002	Shock O-ring Grease, 8cc	TLR Fett 8cc O-Ring	Graisse pour joints toriques, 8cc
TLR8300	TLR Sticker Sheet	TLR Dekorbogen	Planche de décoration TLR
TLR99004	TLR Embroidered Cargo Bag	TLR Tasche	Sac Cargo TLR
TLR99014	TLR Foam Pit Mat	TLR Schraubermitte Schaum	Tapis TLR en mousse
TLR99101	Shock Shaft Pliers	TLR Zange für Dämpferkolbenstange	Pince pour tige d'amortisseur
TLR99102	Turnbuckle Wrench, 22,8B, 8T	TLR Stellschlüssel für Gewindestift, 3.5, 4, 5mm	Clé à biellettes



www.LOSI.com

39540

Created 01/15 LOS04001

©2015 Horizon Hobby LLC.

Losi, 8IGHT-T, AVC, Active Vehicle Control, DSM, DSM2, DSMR, Dynamite and the Horizon Hobby logo are trademarks or registered trademarks of Horizon Hobby, LLC.

The Spektrum trademark is used with permission of Bachmann Industries, Inc. All other trademarks, service marks and logos are property of their respective owners. Patents pending.

800-0518