

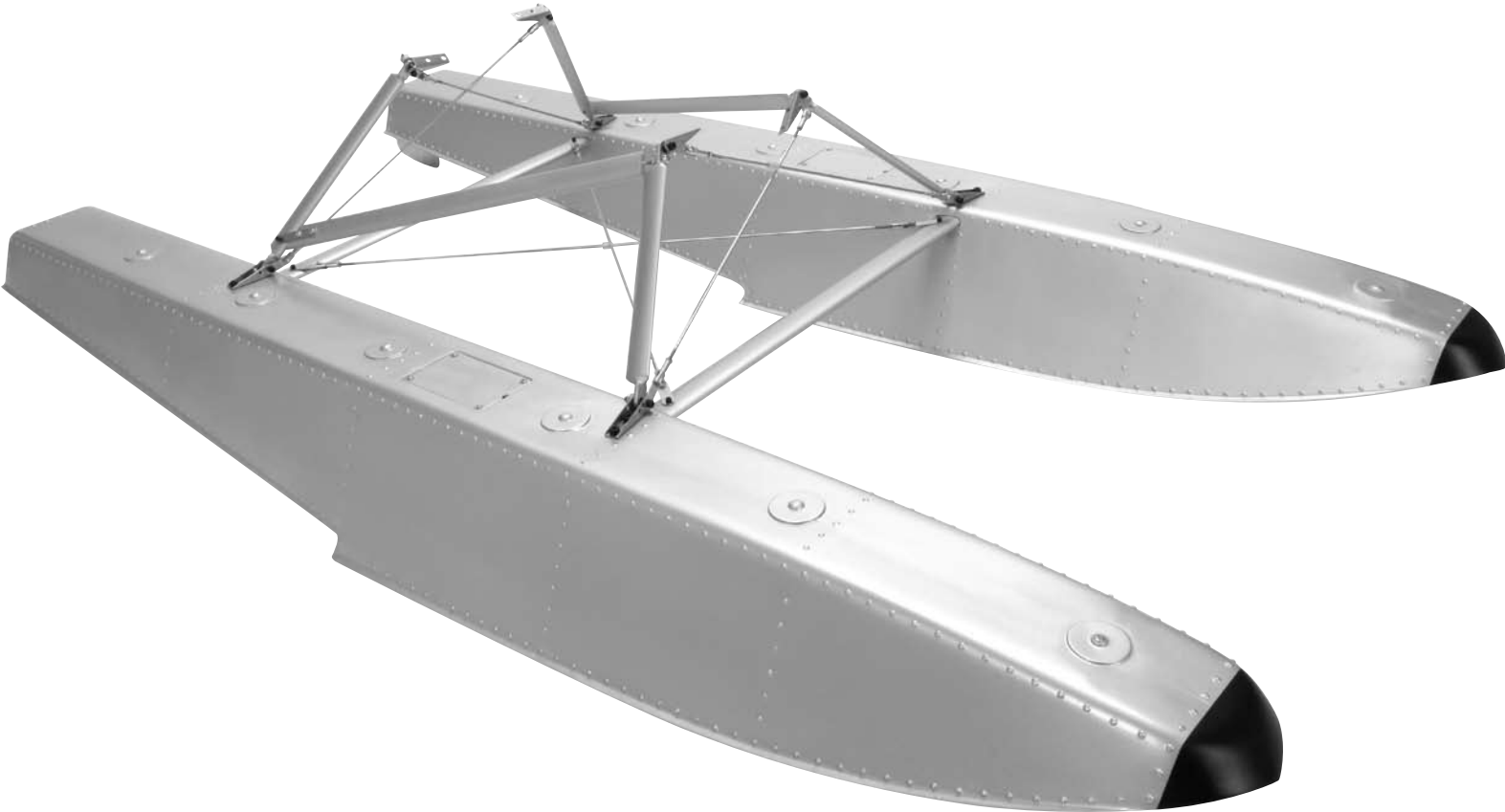

Fly First Class™

1/4-Scale Floats

ASSEMBLY MANUAL



Specifications

Length.....	47.625 in (1210mm)
Overall Width of Float Assembly.....	27.25 in (692mm)
Tip of Float to the Step.....	25.25 in (641mm)
Approximate Weight of Each Float Less Rudder Servo.....	30 oz
Scale Struts Weight.....	15.4 oz
Total Weight.....	75 to 80 oz
For Models Weighing.....	12.0 to 18.0 lb

Table of Contents

- Using the Manual 2
- Required Tools and Adhesives 3
- Before Starting Assembly 3
- Recommended Accessories 3
- FS One 3
- Warranty Period 4
- Limited Warranty. 4
- Damage Limits 4
- Safety Precautions 4
- Questions, Assistance and Repairs. 5
- Inspection or Repairs 5
- Warranty Inspection and Repairs. 5
- Non-Warranty Repairs. 5
- Safety, Precautions and Warnings. 6
- Contents of Kit 6
- Float Assembly 7
- Float Installation 15
- Recommended Center of Gravity (CG) 17
- 2008 Official AMA National Model Aircraft Safety Code 18–19
- Instructions for Disposal of WEEE by Users in the European Union. 20

Using the Manual

This manual is divided into sections to help make assembly easier to understand, and to provide breaks between each major section. In addition, check boxes have been placed next to each step to keep track of each step completed. Steps with a single box () are performed once, while steps with two boxes () indicate that the step will require repeating, such as for a right or left wing panel, two servos, etc. Remember to take your time and follow the directions.

Required Tools and Adhesives

Tools

- Phillips screwdriver: #1
- Drill bit: 5/64-inch (2mm)
- Hobby knife w/ #11 blade
- Hobby knife
- Painter's tape
- Pin drill
- Silicone sealant
- Adjustable wrench
- Ball driver: 1/8-inch, 3/32-inch
- Plastic wrap or waxed paper

Adhesives

- Silicone sealant
- Medium CA
- Threadlock

Before Starting Assembly

Before beginning the assembly of your 25% Fiberglass Floats, remove each part from its bag for inspection. Closely inspect each piece for damage. If you find any damaged or missing parts, contact the place of purchase.

Recommended Accessories

- DS821 Digital Sport Hi-Torque Servo or equivalent (JRPS821) (2)
- 18-inch Servo Lead Extension (JSP98120) (2)

Required when using computer radio:

- 12-inch Servo Lead Extension (JRPA098)
- 6-inch Y-Harness (JSP98020)

Required when using non-computer radio:

- 6-inch Y-Harness (JSP98020) (2)

FS One

With FS One® you get more than photorealistic fields, gorgeous skies and realistic-looking aircraft. You get incredibly advanced aerodynamic modeling that simulates every possible aspect of real-world flight.

The first Hangar Pack™ will add even more aircraft to FS One. This latest edition includes ten new planes and helis from your favorite brands, including Hangar 9, E-flite and Align. You'll be able to fly aircraft that are only available on FS One such as the T-REX, Blade CX2, Blade CP Pro, Hangar 9 P-51 and F-22 PTS. And as always, with the Hangar Pack, you still get all the same great features that you did with the original aircraft.



HANS2000



HANS4010

Warranty Period

Exclusive Warranty- Horizon Hobby, Inc., (Horizon) warrants that the Products purchased (the "Product") will be free from defects in materials and workmanship at the date of purchase by the Purchaser.

Limited Warranty

(a) This warranty is limited to the original Purchaser ("Purchaser") and is not transferable. REPAIR OR REPLACEMENT AS PROVIDED UNDER THIS WARRANTY IS THE EXCLUSIVE REMEDY OF THE PURCHASER. This warranty covers only those Products purchased from an authorized Horizon dealer. Third party transactions are not covered by this warranty. Proof of purchase is required for warranty claims. Further, Horizon reserves the right to change or modify this warranty without notice and disclaims all other warranties, express or implied.

(b) Limitations- HORIZON MAKES NO WARRANTY OR REPRESENTATION, EXPRESS OR IMPLIED, ABOUT NON-INFRINGEMENT, MERCHANTABILITY OR FITNESS FOR A PARTICULAR PURPOSE OF THE PRODUCT. THE PURCHASER ACKNOWLEDGES THAT THEY ALONE HAVE DETERMINED THAT THE PRODUCT WILL SUITABLY MEET THE REQUIREMENTS OF THE PURCHASER'S INTENDED USE.

(c) Purchaser Remedy- Horizon's sole obligation hereunder shall be that Horizon will, at its option, (i) repair or (ii) replace, any Product determined by Horizon to be defective. In the event of a defect, these are the Purchaser's exclusive remedies. Horizon reserves the right to inspect any and all equipment involved in a warranty claim. Repair or replacement decisions are at the sole discretion of Horizon. This warranty does not cover cosmetic damage or damage due to acts of God, accident, misuse, abuse, negligence, commercial use, or modification of or to any part of the Product. This warranty does not cover damage due to improper installation, operation, maintenance, or attempted repair by anyone other than Horizon. Return of any goods by Purchaser must be approved in writing by Horizon before shipment.

Damage Limits

HORIZON SHALL NOT BE LIABLE FOR SPECIAL, INDIRECT OR CONSEQUENTIAL DAMAGES, LOSS OF PROFITS OR PRODUCTION OR COMMERCIAL LOSS IN ANY WAY CONNECTED WITH THE PRODUCT, WHETHER SUCH CLAIM IS BASED IN CONTRACT, WARRANTY, NEGLIGENCE, OR STRICT LIABILITY. Further, in no event shall the liability of Horizon exceed the individual price of the Product on which liability is asserted. As Horizon has no control over use, setup, final assembly, modification or misuse, no liability shall be assumed nor accepted for any resulting damage or injury. By the act of use, setup or assembly, the user accepts all resulting liability.

If you as the Purchaser or user are not prepared to accept the liability associated with the use of this Product, you are advised to return this Product immediately in new and unused condition to the place of purchase.

Law: These Terms are governed by Illinois law (without regard to conflict of law principals).

Safety Precautions

This is a sophisticated hobby Product and not a toy. It must be operated with caution and common sense and requires some basic mechanical ability. Failure to operate this Product in a safe and responsible manner could result in injury or damage to the Product or other property. This Product is not intended for use by children without direct adult supervision. The Product manual contains instructions for safety, operation and maintenance. It is essential to read and follow all the instructions and warnings in the manual, prior to assembly, setup or use, in order to operate correctly and avoid damage or injury.

Questions, Assistance and Repairs

Your local hobby store and/or place of purchase cannot provide warranty support or repair. Once assembly, setup or use of the Product has been started, you must contact Horizon directly. This will enable Horizon to better answer your questions and service you in the event that you may need any assistance. For questions or assistance, please direct your email to productsupport@horizonhobby.com, or call 877.504.0233 toll free to speak to a service technician.

Inspection or Repairs

If this Product needs to be inspected or repaired, please call for a Return Merchandise Authorization (RMA). Pack the Product securely using a shipping carton. Please note that original boxes may be included, but are not designed to withstand the rigors of shipping without additional protection. Ship via a carrier that provides tracking and insurance for lost or damaged parcels, as **Horizon is not responsible for merchandise until it arrives and is accepted at our facility**. A Service Repair Request is available at www.horizonhobby.com on the "Support" tab. If you do not have internet access, please include a letter with your complete name, street address, email address and phone number where you can be reached during business days, your RMA number, a list of the included items, method of payment for any non-warranty expenses and a brief summary of the problem. Your original sales receipt must also be included for warranty consideration. Be sure your name, address, and RMA number are clearly written on the outside of the shipping carton.

Warranty Inspection and Repairs

To receive warranty service, you must include your original sales receipt verifying the proof-of-purchase date. Provided warranty conditions have been met, your Product will be repaired or replaced free of charge. Repair or replacement decisions are at the sole discretion of Horizon Hobby.

Non-Warranty Repairs

Should your repair not be covered by warranty the repair will be completed and payment will be required without notification or estimate of the expense unless the expense exceeds 50% of the retail purchase cost. By submitting the item for repair you are agreeing to payment of the repair without notification. Repair estimates are available upon request. You must include this request with your repair. Non-warranty repair estimates will be billed a minimum of ½ hour of labor. In addition you will be billed for return freight. Please advise us of your preferred method of payment. Horizon accepts money orders and cashiers checks, as well as Visa, MasterCard, American Express, and Discover cards. If you choose to pay by credit card, please include your credit card number and expiration date. Any repair left unpaid or unclaimed after 90 days will be considered abandoned and will be disposed of accordingly. **Please note: non-warranty repair is only available on electronics and model engines.**

Electronics and engines requiring inspection or repair should be shipped to the following address:

Horizon Service Center
4105 Fieldstone Road
Champaign, Illinois 61822

All other Products requiring warranty inspection or repair should be shipped to the following address:

Horizon Product Support
4105 Fieldstone Road
Champaign, Illinois 61822

Please call 877-504-0233 with any questions or concerns regarding this product or warranty.

Safety, Precautions and Warnings

This model is controlled by a radio signal that is subject to interference from many sources outside your control. This interference can cause momentary loss of control so it is advisable to always keep a safe distance in all directions around your model, as this margin will help to avoid collisions or injury.

- Always operate your model in an open area away from cars, traffic, or people.
- Avoid operating your model in the street where injury or damage can occur.
- Never operate the model into the street or populated areas for any reason.
- Never operate your model with low transmitter batteries.
- Carefully follow the directions and warnings for this and any optional support equipment (chargers, rechargeable battery packs, etc.) that you use.
- Keep all chemicals, small parts and anything electrical out of the reach of children.
- Moisture causes damage to electronics. Avoid water exposure to all equipment not specifically designed and protected for this purpose.

Contents of Kit

Replacement Parts

- | | |
|------------|--|
| A. HAN4581 | Left Float w/Hatch |
| B. HAN4582 | Right Float w/Hatch |
| C. HAN4583 | Painted Strut Assembly (including all struts & cross wire bracing) |
| D. HAN4584 | Stainless Water Rudder (each) |
| E. HAN4585 | Stainless Hardware (bolts and brackets) |
| F. HAN4586 | Water Rudder Pushrod |

Available Separately

- | | |
|---------|--|
| HAN4586 | 3/4-inch x 24-inch Aluminum Strut (2) w/(4) End Fittings |
| HAN4587 | 1-inch x 18-inch Aluminum Strut (2) |
| HAN4588 | Strut End Fitting (4) and Attachment Bracket (4) |
| PRB2296 | Rubber Boot (2) |

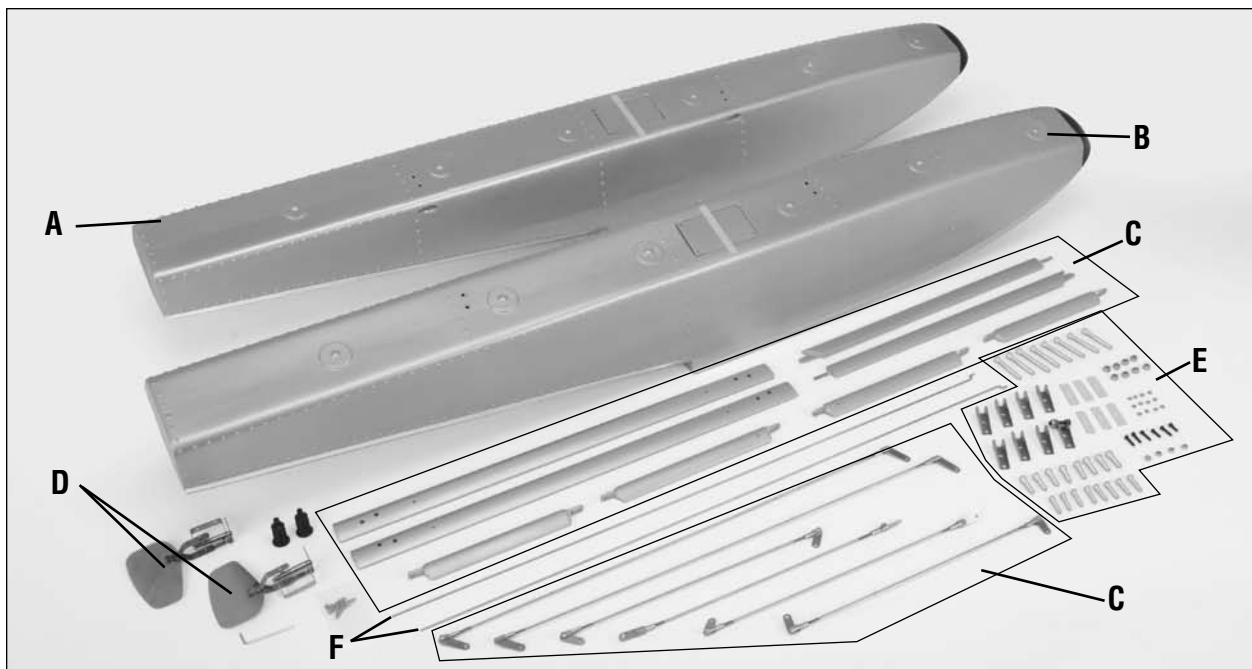

Float Assembly

Required Parts

- Float (right and left)
- Servo hatch (2)
- Strut bracket (4)
- Rubber boot (2)
- Servo (2)
- 4-40 x 3/8-inch socket head bolt (2)
- Rudder assembly (right and left)
- Fuel tubing, 1/4-inch (6mm) (3)
- 10 1/4-inch (260mm) front wire brace w/fittings (2)
- 11-inch (280mm) rear wire brace w/fittings (2)
- 19 1/4-inch (489mm) horizontal wire brace (2)
- #2 x 1/2-inch sheet metal screw (8)
- 8-32 x 1 1/4-inch socket head bolt w/shoulder (4)
- 18-inch (457mm) servo extension (2)
- Aluminum cross brace 1 x 20 1/2-inch (front and rear)
- 4-40 x 1/2-inch socket head bolt (8)
- 27 1/2-inch (700mm) rudder pushrod (2)
- 8 1/2-inch (216mm) rear diagonal strut (2)
- 7 1/2-inch (190mm) front diagonal strut (2)
- 14 1/2-inch (370mm) side diagonal strut (2)
- 8-32 x 3/4-inch socket head bolt w/shoulder (4)

Required Tools and Adhesives

- Phillips screwdriver: #1
- Pin drill
- Drill bit: 5/64-inch (2mm)
- Silicone sealant
- Hobby knife w/ #11 blade
- Adjustable wrench
- Ball driver: 3/32-inch, 1/8-inch
- Hex wrench: 1.5mm (included in float kit)

□□□□ Step 1

Use painter's tape to tape a piece of plastic or waxed paper over the opening for the servo hatch.



□□□□ Step 2

Apply a bead of silicone sealer around the edge of the servo hatch. Tape the hatch tightly against the float. The silicone will create a gasket that will seal the opening after the servo has been installed.

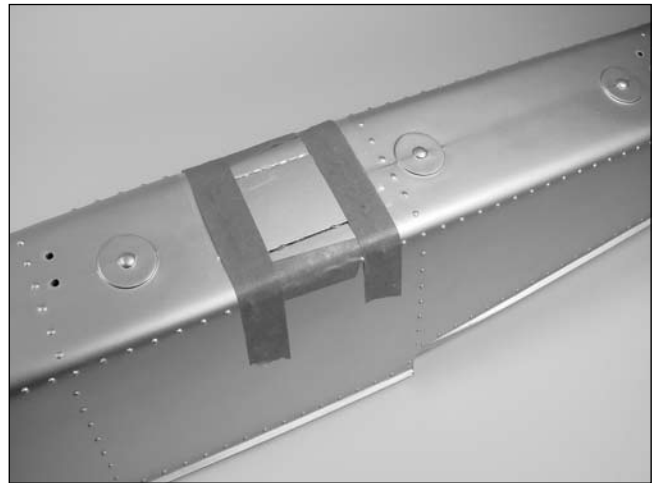

□□ Step 3

Repeat Steps 1 and 2 for the remaining float. Since the silicone will take overnight to dry, it is a good idea to have them both drying to speed assembly the next day.

□□□□ Step 4

Once the silicone has had time to dry, use a hobby knife to trim any that extends outside the hatch.

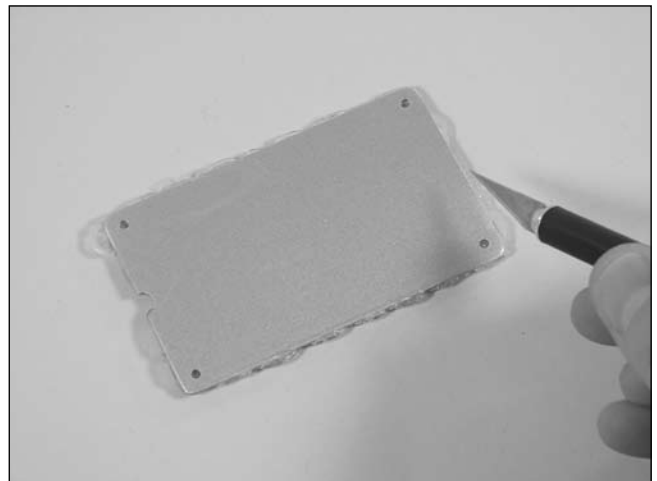

□ Step 5

Repeat Steps 1 through 4 to create a silicone seal for the weight access hatch for both the left and right float.

□□ Step 6

Insert the Z-bend from the 27 1/2-inch (700mm) rudder pushrod into the rudder tiller arm from the bottom as shown.

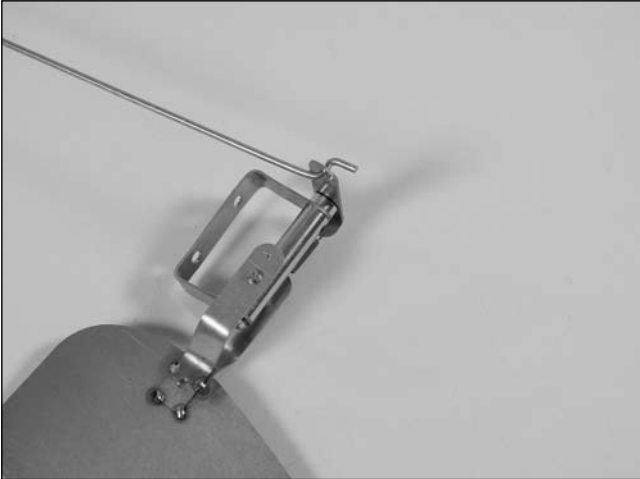

□□ Step 7

Slide the rubber boot onto the pushrod wire. The boot will be pressed against the rudder tiller arm.

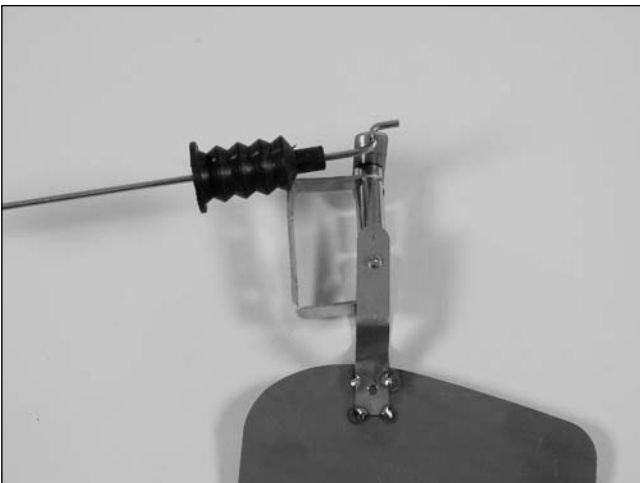

□□ Step 8

Use two 4-40 x 1/2-inch socket head bolts to attach the rudder to the float. Use a small amount of silicone adhesive to secure the rubber boot to the float.

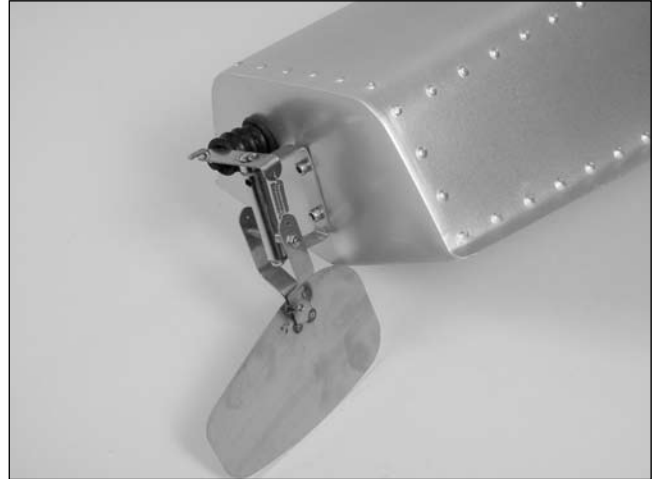

Note: Use care not to get silicone adhesive on the pushrod wire.

Note: Make sure to use threadlock on the screws to prevent them from vibrating loose.

□□ Step 9

Remove the servo arm from the servo. Use the hardware provided with the servo to mount it inside the float. The output of the servo will face toward the front of the float.

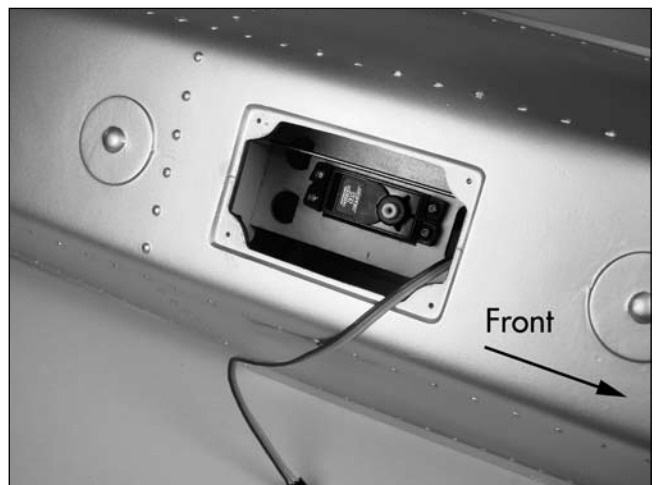

Step 910 Use a pin drill and 5/64-inch (2mm) drill bit to enlarge the outer hole of a standard servo arm. Slide the brass pushrod connector into the hole and secure it using the connector backplate. Remove the additional arms from the horn so they will not interfere with the operation of the water rudder linkage.



Note: Use side cutters to remove any additional servo arms so they do not interfere with the operation of the rudder.

Step 11

Use the radio to center the rudder servo. Slide the connector onto the pushrod wire, then attach the arm to the servo. Center the rudder and use the 3mm x 6mm machine screw to secure the pushrod. Cut the excess pushrod leaving 1/2–3/4-inch (13–19mm) forward of the connector.



Note: Make sure to use threadlock on the screw to prevent it from vibrating loose.

Step 12

Secure an 18-inch (457mm) servo extension to the rudder servo lead. A connector has been supplied to prevent it from becoming unplugged inside the float.

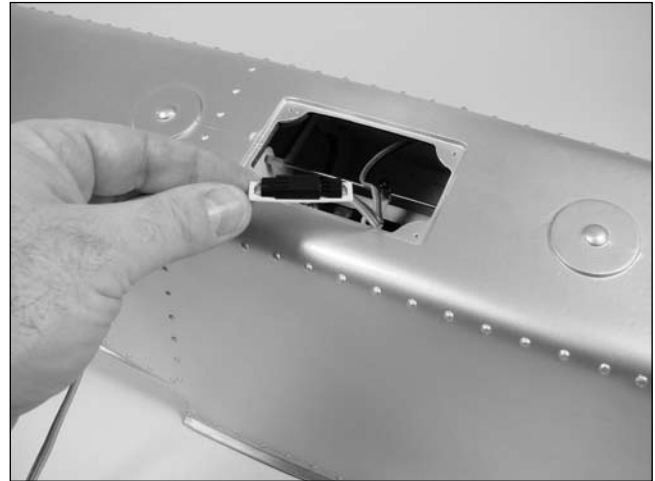

Step 13

With the connection between the servo lead and extension inside the float, place the servo hatch onto the float. Use a #1 Phillips screwdriver to install the four #2 x 1/2-inch sheet metal screws that secure the hatch to the float.

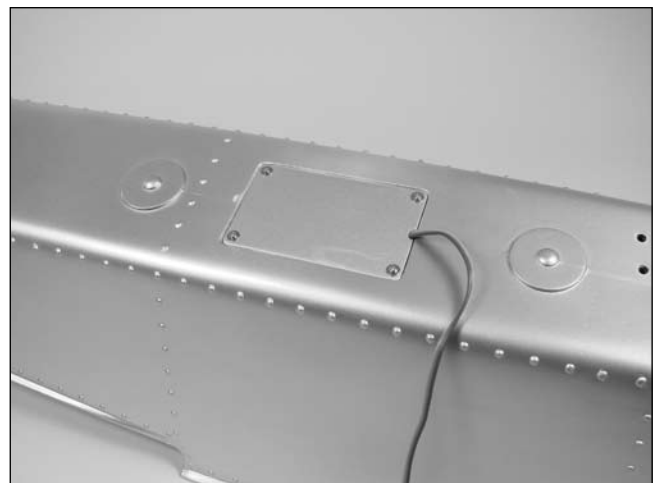

Step 14

Repeat Steps 4 through 13 to install the remaining rudder, servo and linkage.

□□ Step 14

Slide the cross brace into the opening on the side of the float. Check that the holes in the float align with the brace, as there is a front and rear brace and the holes do not match. Use two 8-32 x 1 1/4-inch socket head machine bolts w/shoulder to attach the strut bracket. The screws go through the bracket, cross brace and into the preinstalled blind nuts inside the float.

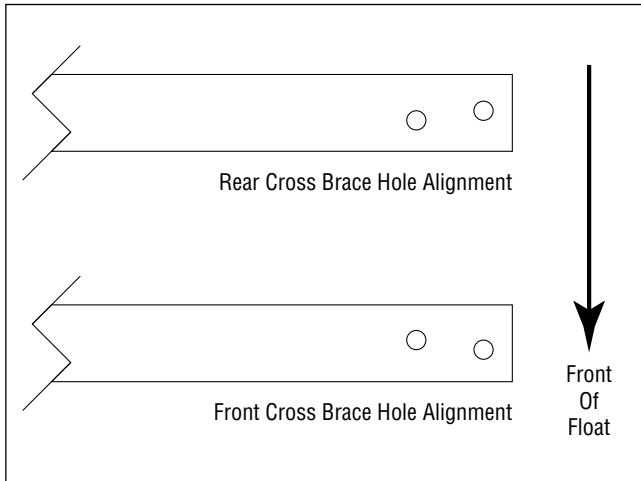

Note: Leave the screws slightly loose until the bracing has been fully installed.

Note: Make sure to use threadlock on the screws to prevent them from vibrating loose.

□□ Step 15

Install the rear cross brace following the same procedure as the previous step.

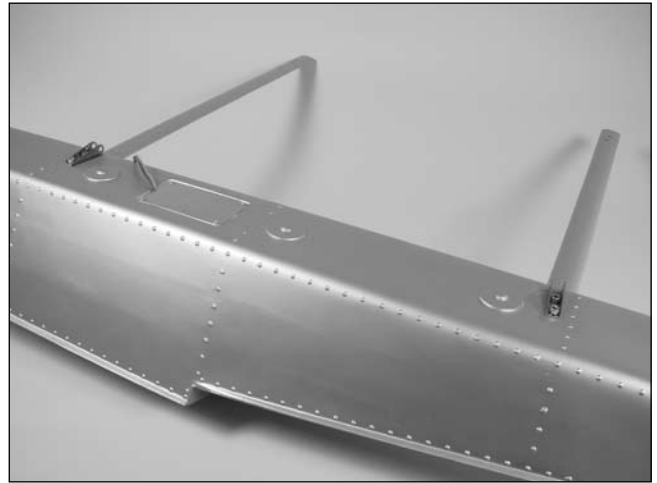

□ Step 16

Repeat the two previous steps to attach the remaining float to the cross braces.

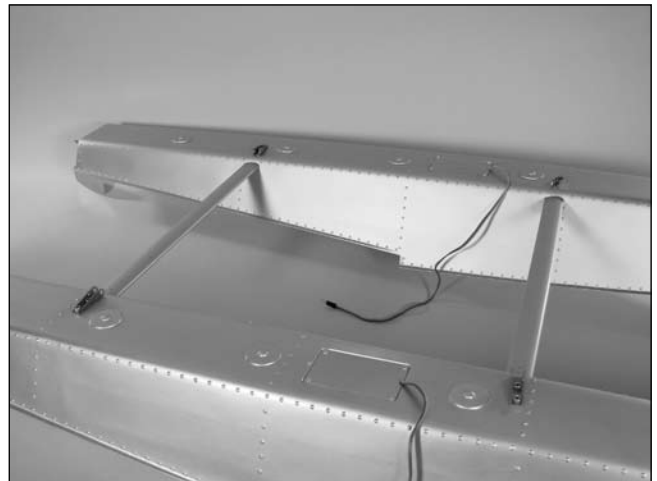

□ Step 17

Remove the strut end fitting from one end of the preassembled 19 1/4-inch (489mm) wire braces. Slide a 1/4-inch (6mm) piece of fuel tubing onto the wire. The fuel tubing will be secured later in the manual.

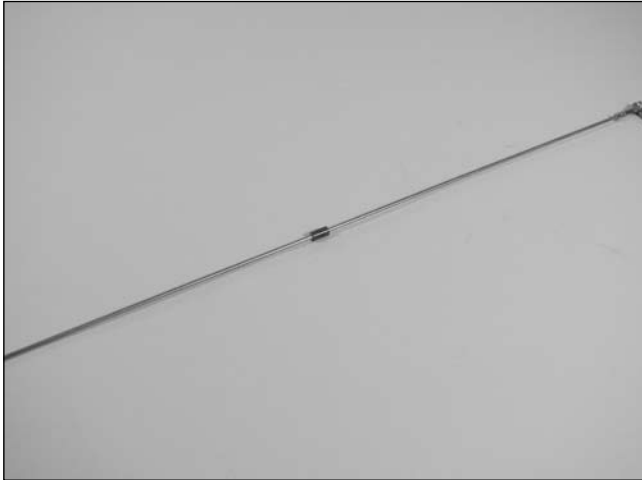

□□ Step 18

Adjust the strut end fittings so the distance between the center of the screw heads will measure 20 1/4-inch (514mm) as shown. Use threadlock on the nuts and ends to prevent them from vibrating loose. The 4-40 nut is then tightened against the ends to keep them from rotating and vibrating loose as well. Prepare both wire braces at this time.

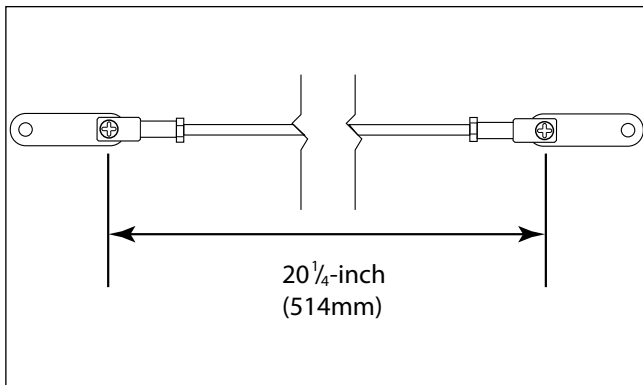

□ Step 19

Use four 4-40 x 1/2-inch socket head screws to attach the wire braces between the cross braces. Once the wire braces are installed, go back and tighten the eight 8-32 x 1 1/4-inch socket head machine bolts w/shoulder. Slide the tubing so it is at the intersection of the two wires to prevent them from rubbing and causing radio interference. Use medium CA to secure the fuel tubing in position.

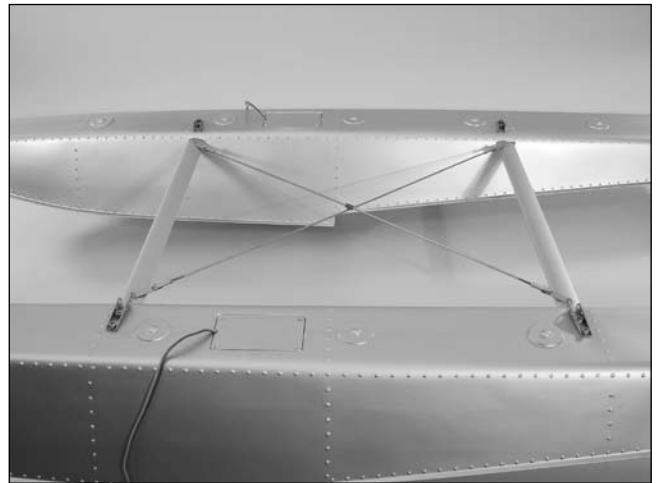

Note: Make sure to use threadlock on the screws to prevent them from vibrating loose.

□ Step 20

Remove the strut end fitting from one end of the preassembled 10 1/4-inch (260mm) wire braces. Slide a 1/4-inch (6mm) piece of fuel tubing onto the wire. The fuel tubing will be secured later in the manual.



□□ Step 21

Adjust the strut end fittings so the distance between the center of the screw heads will measure $11\frac{3}{16}$ -inch (284mm) as shown. Use threadlock on the nuts and ends to prevent them from vibrating loose. The 4-40 nut is then tightened against the ends to keep them from rotating and vibrating loose as well. Prepare both braces at this time.

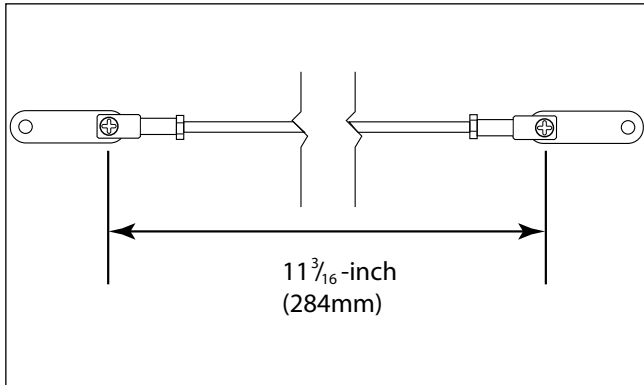

□□ Step 22

Use a 8-32 x 3/4-inch socket head bolt w/shoulder, 8-32 locknut and two #8 nylon washers to attach the $7\frac{1}{2}$ -inch (190mm) front diagonal strut to the strut bracket. Note that the front strut has a hole in one end which the diagonal brace will fit into when installed. Install both front diagonal braces at this time.

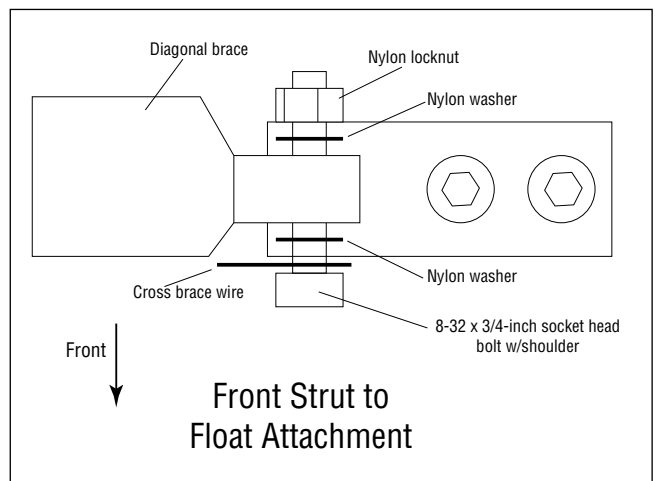
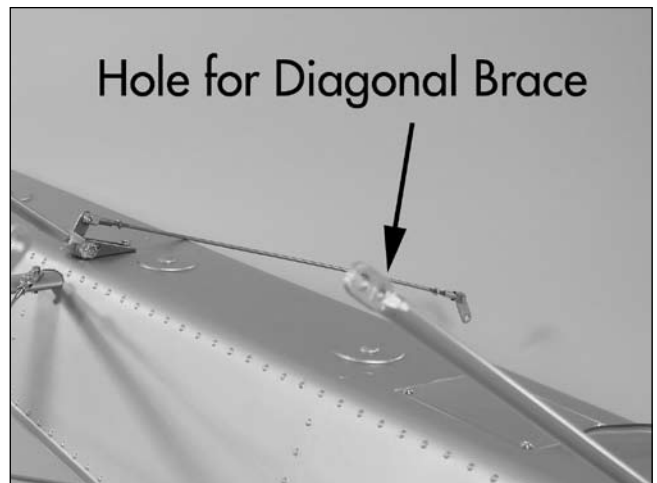
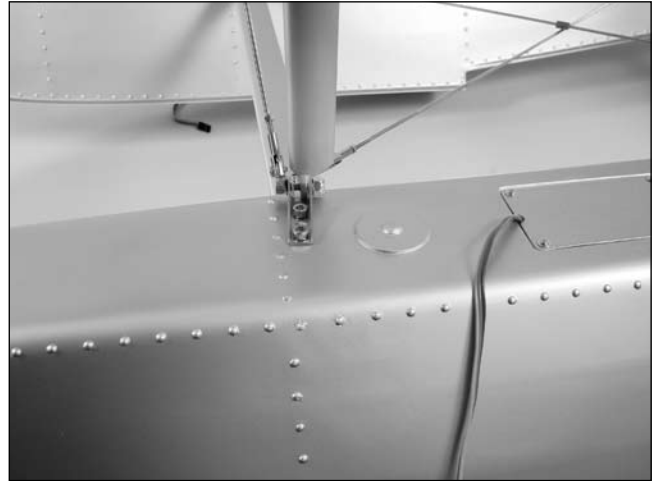

□ Step 23

Remove the strut end fitting from one end of the preassembled 11-inch (280mm) wire braces. Slide a 1/4-inch (6mm) piece of fuel tubing onto the wire. The fuel tubing will be secured later in the manual.

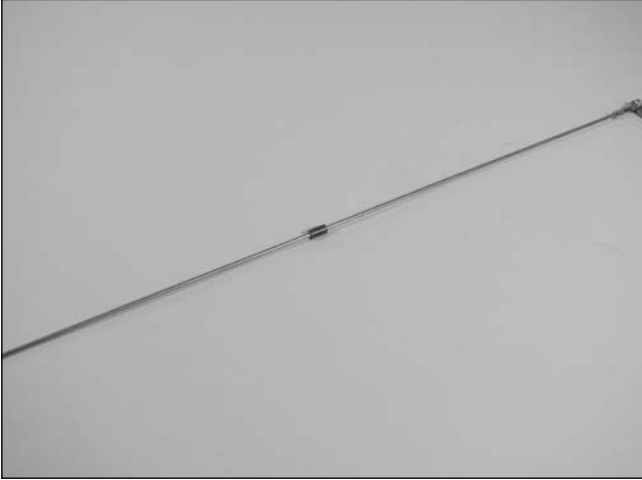

□□ Step 24

Adjust the strut end fittings so the distance between the center of the screw heads will measure $11\frac{7}{8}$ -inch (302mm) as shown. Use threadlock on the nuts and ends to prevent them from vibrating loose. The 4-40 nut is then tightened against the ends to keep them from rotating and vibrating loose as well. Prepare both braces at this time.

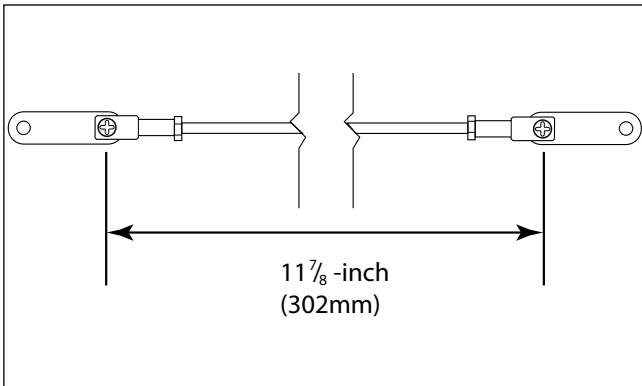

Note: Make sure to use threadlock on the screws to prevent them from vibrating loose.

□□ Step 25

Use a 8-32 x 3/4-inch socket head bolt w/shoulder, 8-32 locknut and two #8 nylon washers to attach the $8\frac{1}{2}$ -inch (216mm) rear diagonal strut to the strut bracket. Note that the front strut has a hole in one end which the diagonal brace will fit into when installed. Install both rear diagonal braces at this time.

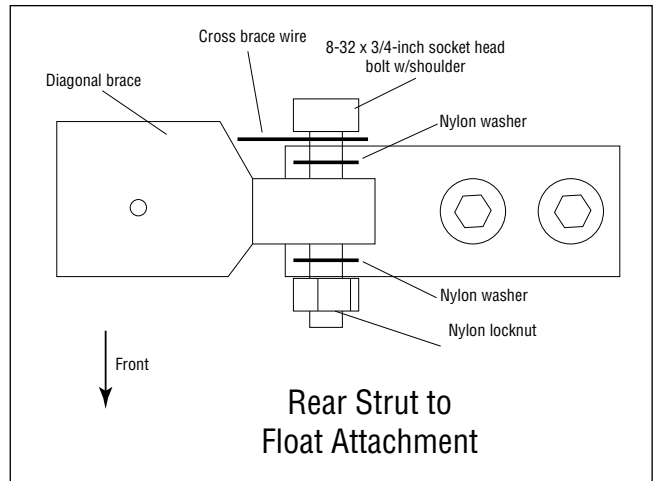
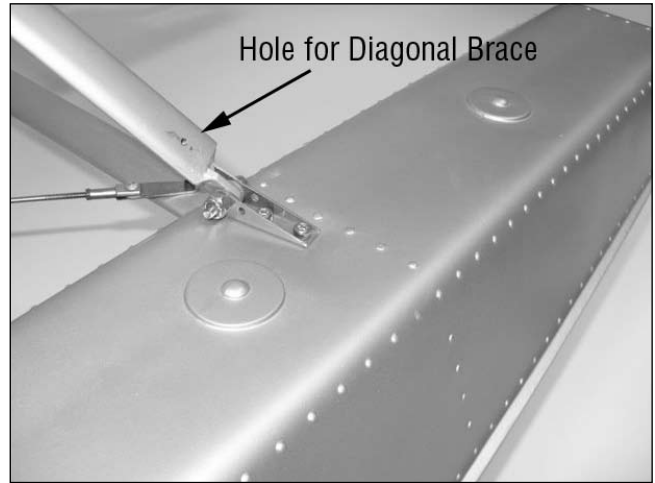

□□ Step 26

Thread a 4-40 nut onto the threaded end of the cross member. The distance from the center of the hole to the end of the nut is $15\frac{1}{8}$ -inch (384mm).

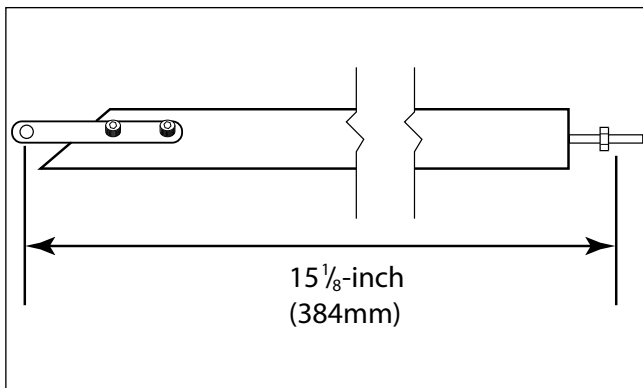

Hint: Apply a drop of threadlock to the threads and then heat the nut with a heat gun and the threadlock will cure and hold the nut in place.

□□ Step 27

Attach the diagonal brace using a 4-40 x 3/8 socket head bolt. Leave the screw loose until the floats have been installed on the fuselage.



□□ Step 28

Thread a 4-40 locknut onto the diagonal brace. Only thread the nut on far enough to keep the diagonal attached to the front cross brace at this time. It will be tightened after the struts have been attached to the fuselage.



□ Step 29

Repeat Steps 26 through 28 to install the remaining diagonal side brace at this time.

Float Installation

Required Parts

- 8-32 x 3/4-inch socket head bolt standard thread (8)
- 8-32 x 3/4- inch socket head bolt w/shoulder (4)
- 8-32 x 3/4-inch socket head bolt from the original J-3 Cub kit(4)
- Strut bracket (4)

Required Tools and Adhesives

- Ball driver: 1/8-inch
- Adjustable wrench
- Hobby knife
- Medium CA
- Threadlock

Step 1

Remove the landing gear from the fuselage. Use a hobby knife to remove the covering over the bolt holes to expose the blind nuts at the rear of the fuselage. Use eight 8-32 x 3/4-inch socket head bolts to attach the strut mounting bracket to the fuselage.

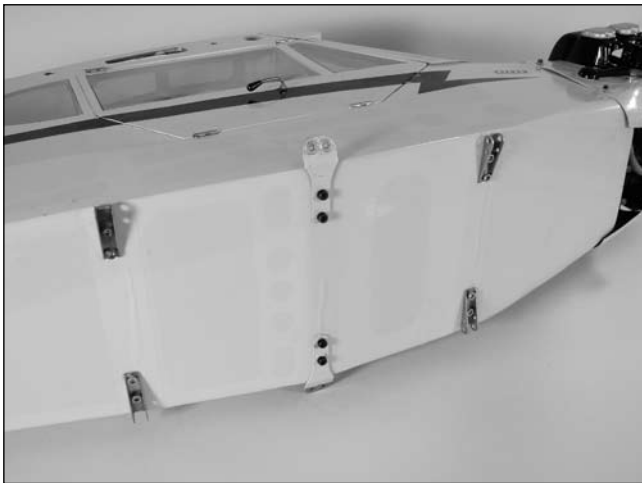

Note: Make sure to use threadlock on the screws to prevent them from vibrating loose.

Step 2

You will need to prepare for the connection of the water rudder servos at this time. There are two options, depending on if you are using a computer radio and plan on using mixing or not:

Option 1: Computer radio

Use a 12-inch (304mm) servo extension from an auxiliary channel that has been mixed to the rudder channel. Secure a Y-harness to the extension. The Y-harness will be mounted so the ends can be accessed from the outside of the fuselage in the next step.

Option 2: Non-Computer radio

Connect a Y-harness to the rudder channel at the receiver. On one end of the harness, connect the rudder servo. On the other, connect another Y-harness. Make sure to secure all connections so they do not become unplugged accidentally. The second Y-harness will be mounted so the ends can be accessed from the outside of the fuselage in the next step.

Step 3

Cut a small notch in the side of the fuselage to mount the end of the Y-harness so the lead from the float can be plugged in.



Hint: Be sure and use silicone to seal the connector to the covering to provide a watertight seal.

□ Step 4

With the fuselage inverted, use two 8-32 x 3/4-inch socket head bolts, four nylon washers and two 8-32 locknuts to attach the front bracing to the float mounting brackets on the fuselage. The bracing and washers are installed in the same fashion at the fuselage as they are at the float. Slide the tubing so it is at the intersection of the two wires to prevent them from rubbing and causing radio interference. Apply medium CA to secure the position of the fuel tubing.

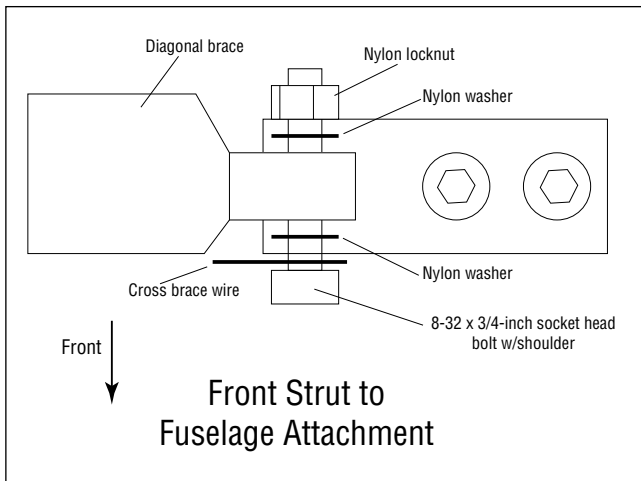
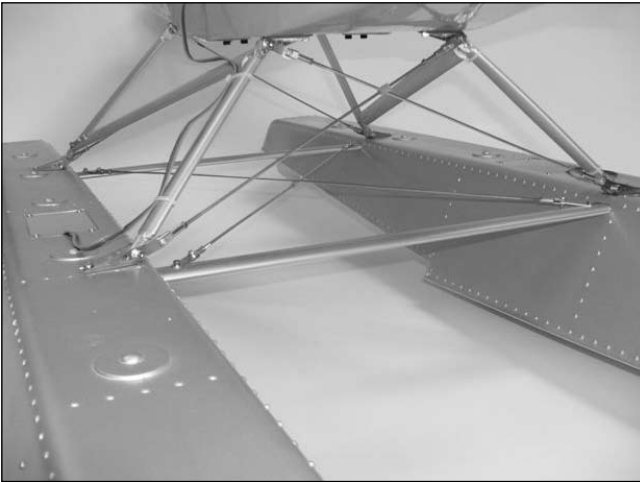

□ Step 5

Use two 8-32 x 3/4-inch socket head bolts, four nylon washers and two 8-32 locknuts to attach the rear bracing to the float mounting brackets on the fuselage. The bracing and washers are installed in the same fashion at the fuselage as they are at the float. Slide the tubing so it is at the intersection of the two wires to prevent them from rubbing and causing radio interference. Use medium CA to glue the tubing in position.

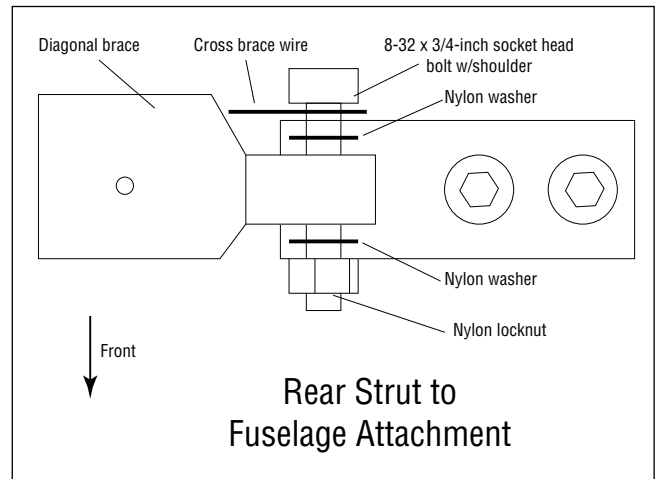
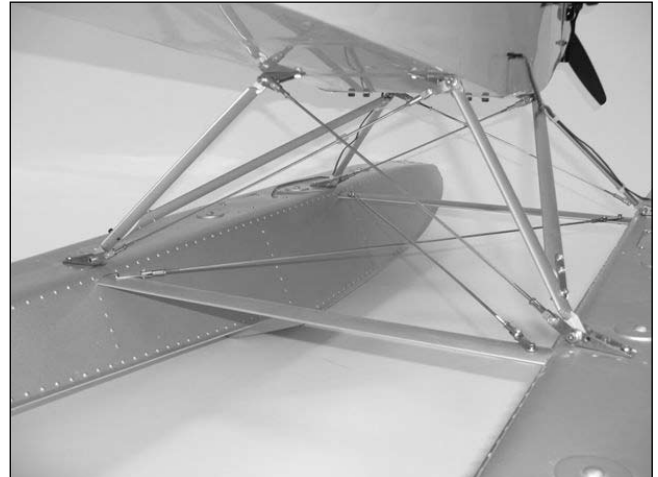

□ Step 6

Plug the lead from the float servo extension into the end of the Y-harness that has been mounted in the side of the fuselage. Use tie wraps to secure the extension to the front diagonal brace to prevent it from becoming damaged if it is left loose to flap freely in the breeze.

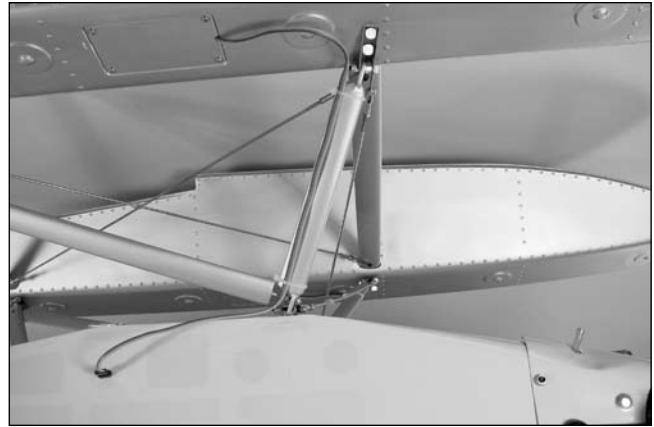

□ Step 7

Now that the floats are installed, go back and make sure all the hardware has been tightened. Slide any extra servo extension lead into the float.

Recommended Center of Gravity (CG)

When installing the floats on your model, you must check the Center of Gravity before flying. The installation of the floats will change the Center of Gravity, and as such, could cause some undesirable flight characteristics or even possibly the loss of your aircraft.

Caution: Do not inadvertently skip this step!

The recommended Center of Gravity (CG) location for the Piper J-3 Cub is CG: $4\frac{1}{2}$ inches (114mm) back from leading edge of wing at the root rib. Mark the location of the CG onto the bottom of the wing using a felt-tipped pen. Make sure the aircraft is upright when checking the CG. If the nose of your aircraft hangs low, add weight to the rear of the aircraft. If the tail hangs low, add weight to the nose of the aircraft. Stick-on weights are available at your local hobby store and work well for this purpose.

The Hangar 9 J-3 Cub will typically need the addition of 2–3 ounces per float.

To do this you can use our HAN3626 lead weight strips (temporarily add these to the top of the floats until you have achieved the proper balance).

Now you can either tape these strips to the outside or, as we have done, you can cut the strips into 1-ounce squares and drop them into the nose of the float through the access hatch. We then poured 1-ounce of epoxy into each float to secure the ballast. Be sure to account for the 1-ounce of epoxy by removing 1-ounce of lead.

The floats are designed with an access hatch in the front to add additional weight in the instance the aircraft is tail heavy. Remove the Phillips screw to access this compartment to add weight to the front of the floats.



The CG range for your Piper J-3 Cub is $4-4\frac{3}{4}$ inches (102mm–120mm) back from the leading edge of the wing at the root rib.

2008 Official AMA National Model Aircraft Safety Code

GENERAL

1. A model aircraft shall be defined as a non-human-carrying device capable of sustained flight in the atmosphere. It shall not exceed limitations established in this code and is intended to be used exclusively for recreational or competition activity.
2. The maximum takeoff weight of a model aircraft, including fuel, is 55 pounds, except for those flown under the AMA Experimental Aircraft Rules.
3. I will abide by this Safety Code and all rules established for the flying site I use. I will not willfully fly my model aircraft in a reckless and/or dangerous manner.
4. I will not fly my model aircraft in sanctioned events, air shows, or model demonstrations until it has been proven airworthy.
5. I will not fly my model aircraft higher than approximately 400 feet above ground level, when within three (3) miles of an airport without notifying the airport operator. I will yield the right-of-way and avoid flying in the proximity of full-scale aircraft, utilizing a spotter when appropriate.
6. I will not fly my model aircraft unless it is identified with my name and address, or AMA number, inside or affixed to the outside of the model aircraft. This does not apply to model aircraft flown indoors.
7. I will not operate model aircraft with metal-blade propellers or with gaseous boosts (other than air), nor will I operate model aircraft with fuels containing tetranitromethane or hydrazine.
8. I will not operate model aircraft carrying pyrotechnic devices which explode burn, or propel a projectile of any kind. Exceptions include Free Flight fuses or devices that burn producing smoke and are securely attached to the model aircraft during flight. Rocket motors up to a G-series size may be used, provided they remain firmly attached to the model aircraft during flight. Model rockets may be flown in accordance with the National Model Rocketry Safety Code; however, they may not be launched from model aircraft. Officially designated AMA Air Show Teams (AST) are authorized to use devices and practices as defined within the Air Show Advisory Committee Document.
9. I will not operate my model aircraft while under the influence of alcohol or within eight (8) hours of having consumed alcohol.
10. I will not operate my model aircraft while using any drug which could adversely affect my ability to safely control my model aircraft.
11. Children under six (6) years old are only allowed on a flightline or in a flight area as a pilot or while under flight instruction.
12. When and where required by rule, helmets must be properly worn and fastened. They must be OSHA, DOT, ANSI, SNELL or NOCSAE approved or comply with comparable standards.

2008 Official AMA National Model Aircraft Safety Code

Radio Control

1. All model flying shall be conducted in a manner to avoid over flight of unprotected people.
2. I will have completed a successful radio equipment ground-range check before the first flight of a new or repaired model aircraft.
3. I will not fly my model aircraft in the presence of spectators until I become a proficient flier, unless I am assisted by an experienced pilot.
4. At all flying sites a line must be established, in front of which all flying takes place. Only personnel associated with flying the model aircraft are allowed at or in front of the line. In the case of airshows demonstrations straight line must be established. An area away from the line must be maintained for spectators. Intentional flying behind the line is prohibited.
5. I will operate my model aircraft using only radio-control frequencies currently allowed by the Federal Communications Commission (FCC). Only individuals properly licensed by the FCC are authorized to operate equipment on Amateur Band frequencies.
6. I will not knowingly operate my model aircraft within three (3) miles of any preexisting flying site without a frequency-management agreement. A frequency-management agreement may be an allocation of frequencies for each site, a day-use agreement between sites, or testing which determines that no interference exists. A frequency-management agreement may exist between two or more AMA chartered clubs, AMA clubs and individual AMA members, or individual AMA members. Frequency-management agreements, including an interference test report if the agreement indicates no interference exists, will be signed by all parties and copies provided to AMA Headquarters.
7. With the exception of events flown under official AMA rules, no powered model may be flown outdoors closer than 25 feet to any individual, except for the pilot and located at the flight line.
8. Under no circumstances may a pilot or other person touch a model aircraft in flight while it is still under power, except to divert it from striking an individual.
9. Radio-controlled night flying is limited to low-performance model aircraft (less than 100 mph). The model aircraft must be equipped with a lighting system which clearly defines the aircraft's attitude and direction at all times.
10. The operator of a radio-controlled model aircraft shall control it during the entire flight, maintaining visual contact without enhancement other than by corrective lenses that are prescribed for the pilot. No model aircraft shall be equipped with devices which allow it to be flown to a selected location which is beyond the visual range of the pilot.



Fly First Class™

Instructions for Disposal of WEEE by Users in the European Union

This product must not be disposed of with other waste. Instead, it is the user's responsibility to dispose of their waste equipment by handing it over to a designated collection point for the recycling of waste electrical and electronic equipment. The separate collection and recycling of your waste equipment at the time of disposal will help to conserve natural resources and ensure that it

is recycled in a manner that protects human health and the environment. For more information about where you can drop off your waste equipment for recycling, please contact your local city office, your household waste disposal service or where you purchased the product.



© 2008 Horizon Hobby, Inc.
4105 Fieldstone Road
Champaign, Illinois 61822
(877) 504-0233
horizonhobby.com