

Name: <u>Kevin M Gahan</u>		Date: <u>2009</u>	Event: <u>Std. Set-up</u>
City: _____ State: _____		Track: _____	
Track <input type="checkbox"/> Indoor <input type="checkbox"/> Tight <input type="checkbox"/> Smooth <input checked="" type="checkbox"/> Hard Packed <input type="checkbox"/> Blue Groove <input type="checkbox"/> Wet <input type="checkbox"/> Low Bite <input type="checkbox"/> High Bite Conditions <input checked="" type="checkbox"/> Outdoor <input checked="" type="checkbox"/> Open <input checked="" type="checkbox"/> Rough <input type="checkbox"/> Loose/Loamy <input checked="" type="checkbox"/> Dry <input type="checkbox"/> Dusty <input checked="" type="checkbox"/> Med Bite <input type="checkbox"/> Other _____			

Front Suspension

Toe: 2 Degree Toe Out

Ride Height: 27mm

Camber: -1 Degrees

Caster: Stock

Sway Bar: 2.3mm

Piston/Oil: 54/40wt Losi

Spring: Silver

Limiters/Droop: _____

Overall Shock Length: 95mm

Steering Ackerman: Long

Bump Steer: Down

Camber Link: 2/A

Shock Location: 2/Inside

Receiver Battery Type: Losi LiPo

Differentials

Front: Standard Smart

Spring Wire Dia: n/a

Qty of Springs: n/a

Ramp Plate: n/a

Grease: n/a

Diff Fluid: 7000wt

Center: Standard Smart

Spring Wire Dia: .15mm

Qty of Springs: 4

Ramp Plate: 120

Grease: Smart diff grease

Diff Fluid: _____

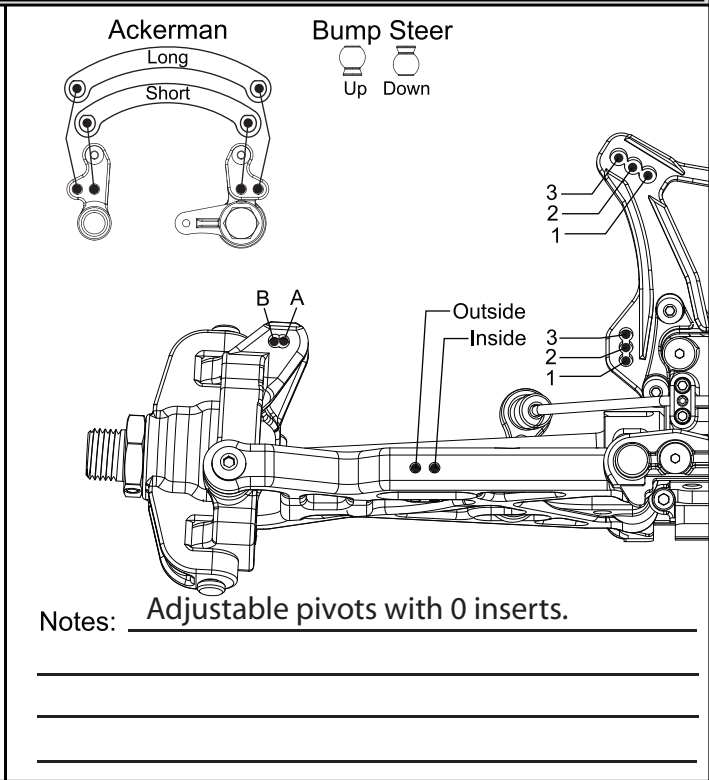

Rear Suspension

Toe: 3 Degrees

Anti-Squat: 3 Degrees

Ride Height: 29mm

Camber: -2 Degree

Rear Hub Spacing: Hubs in back position.

Sway Bar: 2.3mm

Piston/Oil: 56/25wt Losi

Spring: Green

Limiters/Droop: _____

Overall Shock Length: 106mm

Camber Link: 2/B

Shock Location: 2/Inside

Rear Diff Fluid: 3000wt

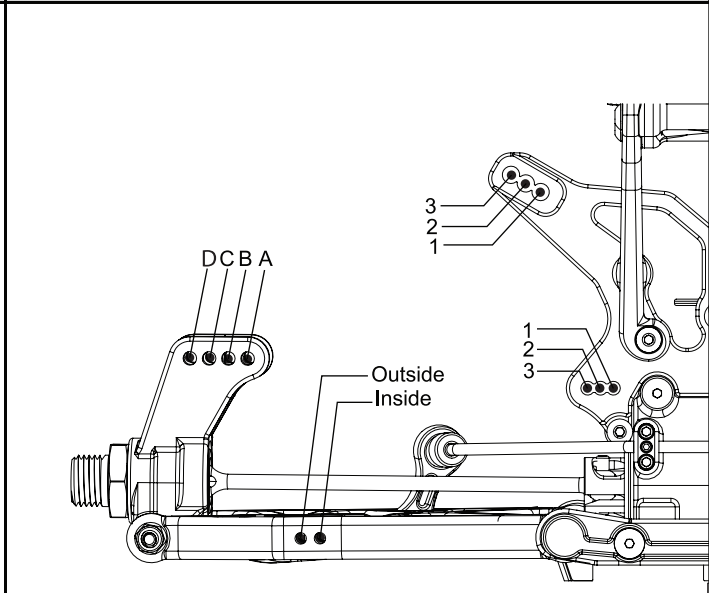

Engine

Engine: GRP .21 Mario Rossi Tuned Fuel: Nitrotane 30%

Glow Plug: GRP C5 Head Clearance: _____

Pipe/Header: GRP 2053 Gearing: 13/48

Notes: Adjustable pivots with 1's up in the front and 0's in the back.

2mm wider rear hubs.

Clutch

Clutch Shoes and Springs Info

2 Aluminum with Gold Springs

2 Plastic with Green Springs

Steel Flywheel

Tires

Type	Compound	Insert
Front: <u>Losi XBT</u>	<u>Red</u>	<u>Losi Yellow</u>
Rear: <u>Losi Eclipse</u>	<u>Red</u>	<u>Losi Yellow</u>

Notes: _____

