

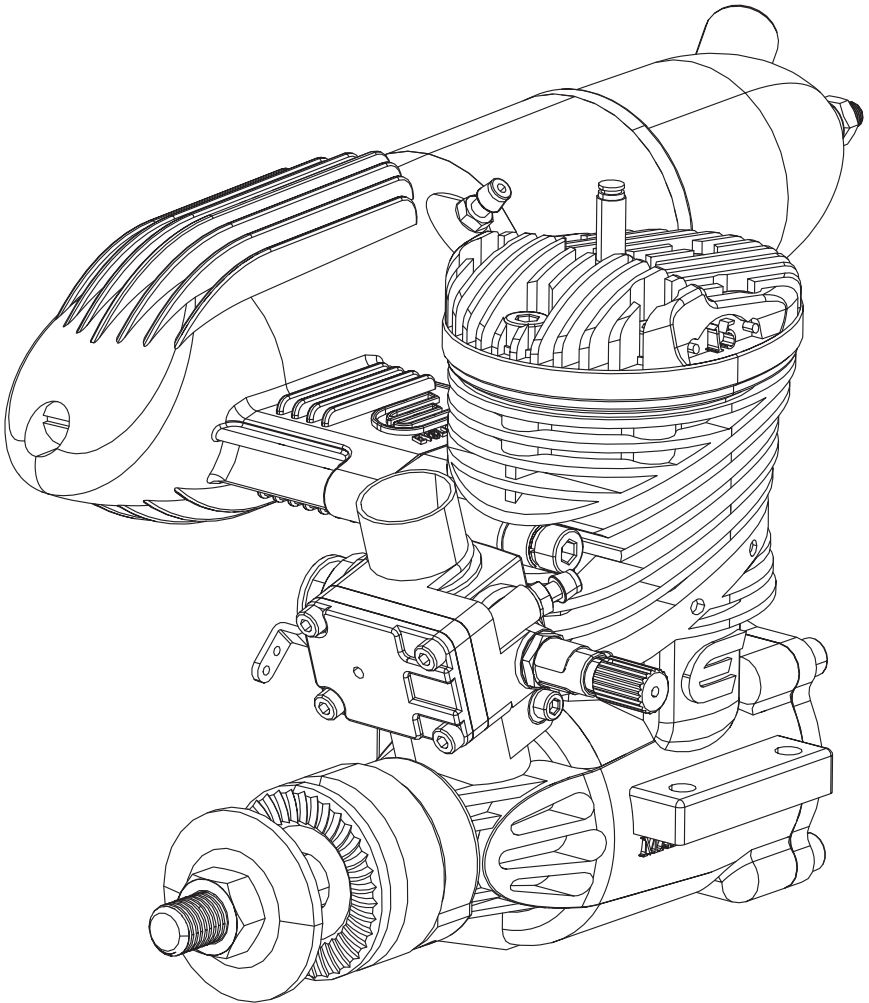

GAS/PETROL

15CC

Evolution® Gas Engines



NOTICE

All instructions, warranties and other collateral documents are subject to change at the sole discretion of Horizon Hobby, Inc. For up-to-date product literature, visit horizonhobby.com and click on the support tab for this product.

Meaning of Special Language

The following terms are used throughout the product literature to indicate various levels of potential harm when operating this product:

NOTICE: Procedures, which if not properly followed, create a possibility of physical property damage AND a little or no possibility of injury.

CAUTION: Procedures, which if not properly followed, create the probability of physical property damage AND a possibility of serious injury.

WARNING: Procedures, which if not properly followed, create the probability of property damage, collateral damage, serious injury or death OR create a high probability of superficial injury.



WARNING: Read the ENTIRE instruction manual to become familiar with the features of the product before operating. Failure to operate the product correctly can result in damage to the product, personal property and cause serious injury.

This is a sophisticated hobby product and NOT a toy. It must be operated with caution and common sense and requires some basic mechanical ability. Failure to operate this Product in a safe and responsible manner could result in injury or damage to the product or other property. This product is not intended for use by children without direct adult supervision. Do not use with incompatible components or alter this product in any way outside of the instructions provided by Horizon Hobby, Inc. This manual contains instructions for safety, operation and maintenance. It is essential to read and follow all the instructions and warnings in the manual, prior to assembly, setup or use, in order to operate correctly and avoid damage or serious injury.



CAUTION: This product can become extremely hot when in use, which could lead to burns.

Age Recommendation: Not for children under 14 years. This is not a toy.

Safety Warnings

Model engines produce a substantial amount of power, which can create unsafe situations if not used correctly. Always use common sense and observe all safety precautions when operating, handling or performing any procedure involving your engine. Failure to follow safety precautions could result in serious injury and property damage.

- Always ensure spectators, especially children, are at least 30 feet away when running the engine.
- Always ensure that the propeller is securely attached to the engine shaft and all retaining fasteners are tightened properly before EACH flight. Use of blue threadlock to tighten nuts is advisable.
- Always keep small parts out of the reach of children as they can be choking hazards.
- Always secure the airplane before powering the engine.
- Always keep your face and body away from the path of the propeller blades when starting or running your engine.
- Always stand behind the propeller when making carburetor adjustments.
- Always wear safety glasses or goggles when starting and running your engine.

- Always keep your fuel in a safe place away from sparks, heat or anything that can ignite.
- Always ensure the aircraft is secure and will not move once the engine is started.
- Always rebind your transmitter to your receiver(s) after setup and before first flight.
- Always ensure the throttle failsafe is set to low throttle in your transmitter.
- Always perform a range check prior to flight.
- Always cut off the fuel supply (pinch or disconnect the fuel line to the carburetor) or use the throttle linkage to shut off the air in order to stop the engine.
- Never use hands, fingers, or any other body part to stop the propeller.
- Never throw any object into a propeller to stop it.
- Never run the engine in the vicinity of loose small objects, such as gravel or sand, to avoid the propeller uncontrollably throwing such materials.
- Never wear loose clothing or a loose neckstrap when operating your model engine as these items could become entangled in the propeller.
- Never have loose objects such as screwdrivers, pencils, etc. in your pockets when operating your model engine. These could fall into the propeller.
- Never allow fuel to come into contact with eyes or mouth. Gasoline and other fuels used in model engines are poisonous.
- Always ensure gasoline and fuel are stored in a clearly marked container away from the reach of children.

Precautionary Guidelines

- Always mount the engine securely on a bench mount or high-quality engine mount.
- Always use the correct size and pitch of propeller for your engine. Refer to the Propeller Chart in this manual.
- Always confirm proper balance of your propeller prior to installation of the engine. Failure to do so could result in damage to the engine and/or airframe.
- Always utilize an electric starter to start your engine.
- Always discard any propeller that is nicked, scratched, cracked or damaged in any way.
- Always run your model engine in a well-ventilated area. Model engines can produce possibly harmful carbon monoxide fumes.
- Always store your fuel safely in a sealed, water-resistant container.
- Always store fuel in a cool, dry location. Do not allow fuel containers to come in direct contact with concrete, as the fuel may absorb moisture.
- Always responsibly discard fuel if there is condensation and/or water inside the fuel container.
- Never return unused fuel from the fuel tank back into the fuel container.
- Never attempt to repair or modify a propeller beyond its intended use.
- Never handle model engines, mufflers and/or tuned pipes until they have had time to cool. They can become extremely hot when in use.

Introduction

Congratulations on your purchase one of the exciting new engines in the Evolution® small block gas engine series. All of the Evolution brand gas engines are designed from the start to provide you with excellent performance at a fraction of your previous operating costs. We have painstakingly designed and tested each engine to insure a hassle-free experience without giving away anything in expected performance or durability. This manual, when read and followed, will guide you through the simple steps to your success. Welcome to the Evolution family.

Small Block Gas Engine Design

Starting with our already proven glow engines enjoyed by thousands around the world, we endeavored to take that excitement and experience into the realm of gasoline fuel to provide you with a complete package; great performance and low cost of operation.

Step 1 *Start with a great engine.* The Evolution glow engines have provided thousands of users excellent performance.

Step 2 *Design a new carburetor system that will be reliable and provide for hassle-free use by the owners.* This new carburetor, with already proven technology, was modified to fit in the available space in front of the cylinder and the unique needs of a gasoline fueled engine. Built on to the front of the carburetor is a crankcase-pressure driven regular system. This system takes fuel from a muffler pressurized tank and meters it properly in all attitudes of flight. A new cat's eye style fuel metering system was added to allow for more controllability to the low and mid-range throttle positions.

Step 3 *Design the proper muffler system to handle the extra heat and expansion of the burnt gas mixture when compared to a glow system.* These changes included adding volume to the muffler, including a much larger muffler through bolt to handle the heat and stress, and enlarging the outlet of the muffler to minimize backpressure while still providing noise reduction.

Step 4 *Design operating accessories that enhance the user experience.* During our extensive 2 1/2-year testing program we discovered a lot of new techniques and obstacles that are unique to gasoline fueled small block engines.

- Because the amount of fuel consumed is one third that of a comparable sized glow engine, the construction and reliability of the fuel delivery system to the carburetor becomes three times as critical. Microscopic pieces of dirt that used to safely pass through the larger fuel passages of a glow carburetor will wreak havoc on a gasoline system. By using a quality inline filter like our Inline Filter (EVOA105) we can take care of the dirt problem. One of these is included with your engine.
- The same holds true for air bubbles from the tank or any small leak in the fuel tubing; what would pass harmlessly through a glow carburetor simply is not tolerated in a gasoline system because the air bubbles are effectively three times the size they used to be. We have developed and sourced an excellent felt filter clunk that, when used in the tank, stops all the air bubbles from moving into the fuel delivery tubes. This felt clunk is critical to successful and reliable operation. One of these is included with your engine.
- We found that high muffler temperatures would destroy normal Tygon® tubing (the go-to choice for gasoline engines) within minutes. We found that Neoprene tubing would withstand the temperatures but it tended to degrade quickly in use. We sourced the proper sized fluoroelastomer tubing (FKM tubing), which withstands not only the high temperatures, but its durability is much greater than that of either Tygon or Neoprene. The added bonus is that it fits and holds well to the fuel fittings without any need for additional wire or tie-wrap keepers. We have included a supply of this tubing with your engine.

Included Content

ENGINE

- Muffler (EVOG15601)
- Muffler Screws & Gasket (EVO9191A)
- Spark Plug (EVOG10350)
- Evolution/Spektrum™ Telemetry RPM adapter cable (EVOA107)
- Medium Gas-FKM Fuel Tubing (EVOA104)
- In-Line Fuel Filter (EVOA105)
- In-tank Felt Filter/Clunk (EVOA106)

OPTIONAL ITEMS

- Tachometer (HAN156)
- Propeller 13 x 6 (EVO13060) for break-in; 14 x 6 (EVO14060) for normal flight
- Optical Electronic Ignition Kill Switch (EVOA100)
- Evolution Synthetic 2-Cycle Oil, (EVOX1001Q)
- Ultra Fuel Pump (HAN155)

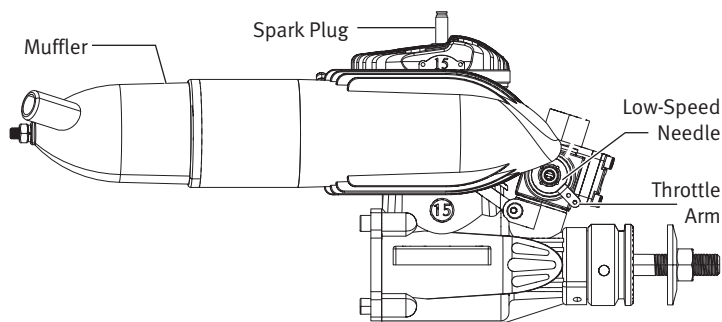
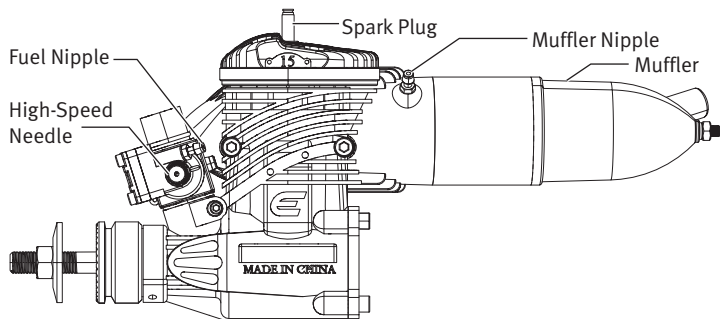

Installing the Engine

1. Secure the engine mount on the airplane firewall. Tighten the engine mount screws in the firewall.
2. Install the engine on the engine mount according to the airplane manufacturer's instructions.



WARNING: Tighten all engine mounting screws before each flight. If you do not tighten the engine mounting screws, the screws may vibrate loose and cause the engine to separate from the fuselage.

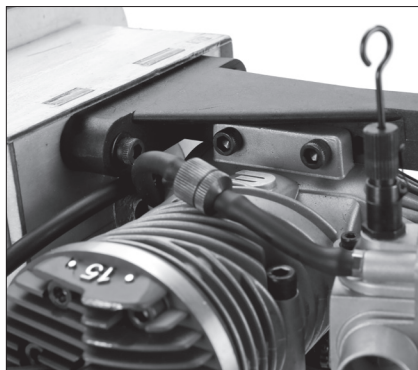

Installing the Muffler

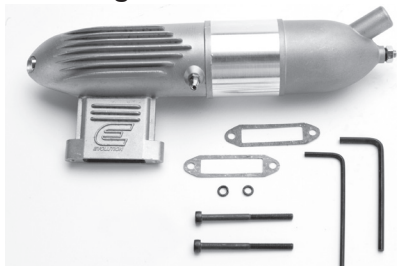

The muffler mounting accessory package includes mounting screws (2), lock washers (2), muffler gaskets (2) and L-wrenches (2).



1. Put a lock washer on each of the muffler screws. Push the muffler screws through the cylinder head.
2. Place the muffler gasket over the engine mounting screws.
3. Align the muffler gasket with the exhaust opening and the muffler mounting screws.
4. Tighten the muffler screws.

IMPORTANT: Tighten the muffler screws after five tanks of fuel. The muffler screws may loosen from heat and vibration.

It is important that you tighten the muffler through bolt after each of the first three, full tank engine runs. The heat will cause expansion of the through bolt and muffler body parts. After the third tightening, no further muffler loosening should occur.

To tighten the muffler through bolt:

1. Loosen the muffler lock nut.
2. Tighten the muffler through bolt screw.
3. Tighten the muffler lock nut.

Connecting the Throttle Linkage

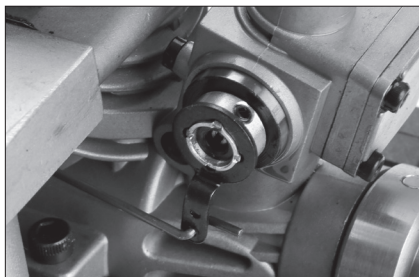

1. Use a secure method to attach the throttle linkage to the throttle arm on the carburetor.
2. Power on the transmitter and receiver.
3. Move the throttle stick to the middle stick position.
4. Adjust the throttle arm so the arm is 90 degrees to the throttle pushrod.
5. Center the throttle servo. Install a servo with a hole 11mm (7/16 in) from the center of the arm.
6. Use a clevis to attach the throttle linkage to the servo arm.

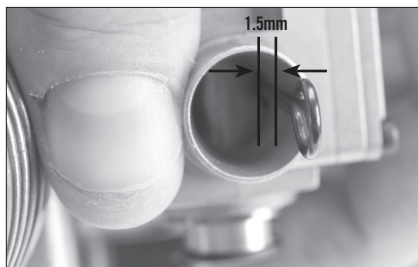
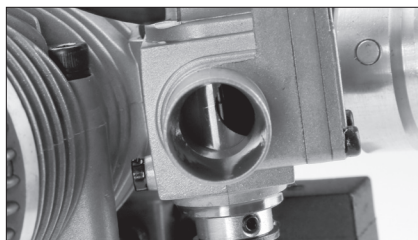
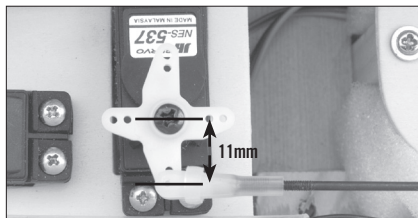

Adjusting the Throttle Opening

1. Lower the throttle and center the throttle trim.
2. Adjust the length of the throttle linkage until the throttle is open 1mm.
3. Move the throttle stick up to confirm the throttle opens. If the throttle does not open, reverse the throttle channel in your transmitter.
4. Move the throttle stick and throttle trim down to confirm the throttle closes.
5. If you reversed the throttle channel in your transmitter and you are using a 2.4GHz radio system, you must re-bind your radio system to set the correct failsafe position.

Attaching the Fuel Lines

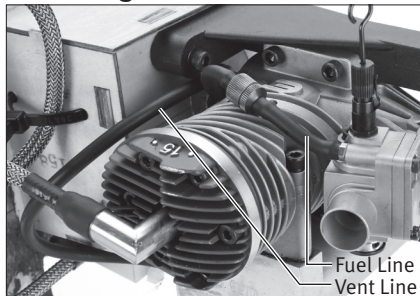

1. Connect medium diameter FKM fuel line to the carburetor and the fuel tank supply line.
2. Connect medium diameter FKM fuel line to the muffler pressure nipple and the fuel tank vent line.

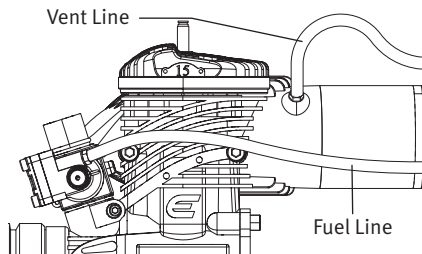

RECOMMENDED PROPELLERS

13 x 6–15 x 6 (14 x 6 has tested to be the best performer with this engine, although the performance is very good throughout the recommended range)

Attaching the Propeller and Spinner

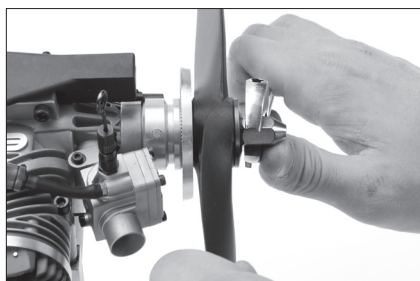

1. Remove the prop nut and prop washer from the crankshaft.
2. Install the spinner backplate, followed by the propeller, prop washer and prop nut.
3. Cover the propeller with a cloth and use an adjustable wrench to tighten the prop nut.



Aftermarket muffler (BISo4091) shown. Not included.

4. Install the spinner cone. Make sure the spinner cone is not touching the propeller. Trim the propeller opening if necessary.
5. Tighten the spinner screw(s) to secure the spinner cone.

Connecting the Electronic Ignition

The Evolution Electronic Ignition Assembly is designed and engineered specifically for the small block engine series. It is smaller and lighter so it fits into tighter spaces of the airplanes the engines are designed to power. The battery voltage required is between 4.8V (4-cell Ni-MH pack) and 8.4V (2S Li-Po battery) and no voltage regulators are needed with any of these batteries. We recommend a 2S Li-Fe battery (such as the Team Orion® Avionics Li-Fe Receiver Pack 1300mAh 6.6V (ORI60503)) and we have done extensive testing with these packs. The maximum amp draw at full throttle is 450mAh, and our more typical average has been between 250–300mAh.

The assembly consists of:

- Ignition module with battery connector, ignition sensor connector, tachometer readout connector and spark plug connector
- Ignition sensor (already attached to your engine)
- Sensor magnet (already installed in the prop drive hub of your engine)

Mounting Your Electronic Ignition

- You can mount the unit in any orientation and place that is convenient for your installation. The module is sized to conveniently fit into the tank compartment of most glow powered airplanes alongside or underneath the recommended fuel tanks. You can also mount it to the firewall or under the engine firewall extension if your airplane is so equipped. Keep in mind that it should be mounted away from the heat of the muffler.
- Secure the ignition module to your chosen location with foam padding to provide vibration isolation. We typically mount it conveniently with tie wraps after wrapping the ignition in lightweight 1/4-inch foam rubber.
- You may need to route both the spark plug connector wire and the ignition sensor wire through the firewall, so be sure to plan ahead and provide adequately sized holes that will allow you to pull either the ignition sensor connector or the spark plug cap connector through the holes for later ignition removal.
- Mount a good quality radio receiver type switch between the ignition unit and the battery. Mount this switch in a convenient place on the outer fuselage close to the front of the airplane to make it easy to turn the ignition on and off. Being able to easily shut off the ignition is an important safety consideration.
- For added security and controllability, add an additional radio-operated kill switch (such as the Optical Ignition Kill Switch EVOA100) between the ignition battery connector lead and the ON/OFF switch.
- Connect the ignition sensor wire to the ignition module. The sensor wire will only fit into one of the connectors so you cannot connect it wrong.
- Connect the ON/OFF switch to the battery connector lead of the ignition module. This connector is the red connector.
- If desired, you can connect either the separately available tachometer readout or the included Evolution/Spektrum Telemetry Adapter Cable (EVOA107) to the tachometer readout connector. Plug the other end of the adapter cable into your telemetry module's rpm input port.
- Connect the spark plug connector to the spark plug. This adapter has a push on and rotate clockwise 1/8 turn locking mechanism to insure a solid connection.

Make sure you charge your ignition battery and are now ready to operate your electronic ignition with the engine.

Fuel

This engine requires a mix of 20:1 gas to oil lubricant ratio for break-in and a mix of 32:1 gas/oil ratio for normal operation in order to last a long time.

The needle bearing at the bottom end of the conrod depends upon this lube ratio to operate properly.

Do not go higher than a 20:1 gas/oil ratio for the first gallon of fuel. After this you may decrease the oil content to a 32:1 gas/oil ratio if desired. Do not go higher than a 32:1 gas/oil ratio or the warranty on your engine will be voided.

Fuel Delivery System

It is very important to properly construct your fuel supply system to the engine to avoid operating problems. Our experience has shown that many seemingly engine related operating problems are in fact fuel delivery problems, not engine related problems.

Fuel Filtering - Because of the incredibly small amount of fuel that is being used by this engine, filtration of the fuel is mandatory in three different spots in the system:

1. Between the fuel jug and the tank.
2. Within the fuel tank itself (with a filtered clunk EVOA106).
3. Between the fuel tank and carburetor (with an in-line fuel filter EVOA105).

Both of these filters (2 and 3) are included in the engine package.

Tank Location - Because muffler pressure is used to provide the pressurization to the fuel regulating and metering carburetor, the tank still needs to be mounted in line with the carburetor, and as close to the rear of the engine as possible. Care taken in mounting the tank as described will provide trouble free operations in all flight attitudes.

Tank Choice and Construction – Choose a tank between 8–14 oz (240–420 mL). These tanks will yield 12 minutes (for the smaller tank) to 25 minutes (for the larger tank) of full throttle flying time.

To properly mix the fuel, for a mix of 20:1 gas to oil, add 6.75 oz of good quality 2-stroke oil to one gallon (or 53 mL of oil to one liter) of 87–93 octane fuel. (EVOX1001Q Evolution 2-stroke oil is recommended) We prefer to add the oil first to our fuel container and to add the gasoline second. This helps to insure a good mixture of the oil with the fuel at the outset.

We have tested our own Evolution 2-stroke oil, Valvoline, Shell, RedLine and Husqvarna oils. Other quality 2-stroke oils should work as well. Do not use Amsoil synthetic oil in any form.

- Ensure you use a tank stopper made for use with gasoline and/or smoke oil.
- We suggest a three-line tank system; one for the line to the carburetor with the clunk attached internally, one for the muffler pressure to the tank, and one dedicated to fueling/defueling the tank. We try to avoid the T-fittings and other inline valves because they can be a possible source of air/fuel leaks.
- Ensure you use the provided FKM tubing in all the plumbing of the tank, externally and internally.
- Ensure you use the included felt filter clunk inside the fuel tank.
- Ensure you use the included inline filter between the tank and the carburetor.
- Ensure there is a good seal system for the dedicated fueling/defueling line. We highly recommend the HAN116 Fuel Filler Assembly for its sleek look and ease of use when installed on your airplane.

Engine Break-in

Your new engine needs to be broken-in to ensure a long life of all the components. This engine features a piston ring design, which requires a specific break-in procedure to ensure a tight seal between the piston ring and liner. For this to be accomplished, this process requires repeated heating and cooling cycles, and must be done at a needle setting that is slightly rich of peak to ensure the ring expands and contracts. The ring needs to “grow” into the liner for it to develop a good seal.

Breaking in the piston ring and liner by running it too rich does not provide the necessary parts growth to accomplish the needed piston ring and liner fitting. However, using too lean of a setting will cause the ring to become damaged by overheating. Please follow the steps below to ensure a successful experience.

Important considerations during break-in

- Perform the break-in process with the engine mounted on your airplane. There is no need to bench-run the engine prior to mounting it on your airplane.
- Use the suggested break-in prop to begin your break-in process. This provides a light load and high rpm that, when matched with the heat of the engine, will break in the engine properly.
- Use the proper recommended fuel with a 20:1 gas to oil ratio for the first gallon of operation.

The proper break-in flight procedure is to fly the airplane at full throttle through a series of figure eight maneuvers (i.e. Cuban Eight). These maneuvers in particular benefit the engine because, when climbing, the additional load on the engine will increase the temperature and, when diving, the lighter load and higher rpm will decrease the temperature, thus providing the heating/cooling cycles required for the break-in process.

Break-in process

- **First tank of fuel:** Set the high-speed needle valve at 1.25 turns out and use the suggested break-in prop. Run the engine on the ground for its first tank of fuel and DO NOT go above half throttle. Cycle the throttle between idle and half throttle every minute.
- **Second tank of fuel:** Tune the needle valve to be slightly rich of the peak RPM at full throttle without a drop in RPM. Do not run at full throttle on the ground for more than 30 seconds at a time. Tune the low speed needle valve for a smooth transition from idle to mid-range, go back to full throttle to confirm the main needle valve setting and then fly. During this flight, be sure to be conscientious of extended periods of heating the engine. Be sure to mix-in some cool-down dives and lower-throttle flying.
- **Third tank of fuel:** Fly the engine at a high throttle while performing the recommended figure eight maneuvers. This will help the piston ring and cylinder liner to expand and contract; helping the breaking-in process. Tune the needle valve to be slightly rich of the peak RPM as necessary.
- **Fourth tank of fuel:** Select one of the recommended propellers for normal operation and mount it on your engine. Tune the main needle valve to be slightly rich of the peak RPM and the low speed needle valve for a smooth transition from idle to full throttle and continue to break-in the engine in flight.

Do not worry about an engine setting being slightly rich during this process. When set correctly, the engine will occasionally sound as if it is misfiring (which it is). During the climbing maneuvers this should go away and might return during the diving maneuvers. If it does not go away during the climbs, land the airplane and lean the high-speed needle by 1–2 clicks, then take off and fly again. Enjoy the break-in process—you are doing a lot of flying.

Continue to fly the airplane through the first gallon of fuel and then change the fuel mixture to 32:1 for continued operation.

Telemetry

Telemetry is a huge asset to help you tune your engine. The ignition module is even capable of communicating with Spektrum telemetry systems directly so you won't have to add an additional RPM sensor. You will need to connect the Evolution Ignition Telemetry Adapter (EVOA107) between the RPM port on the ignition unit and the RPM port on your Spektrum telemetry module in order to utilize this feature. Telemetry systems other than Spektrum may require a dedicated RPM sensor.

We recommend using the Spektrum DSMX Full Range Aircraft Telemetry Module (SPM9548) in conjunction with the included adapter. This system allows you to see real-time RPM and temperature readings from the engine.

The temperature sensor should be wrapped around the base of the spark plug on the cylinder head. Using telemetry gives you an accurate representation of actual temperature and rpm figures during use, and warnings can be set to go off if your engine is getting too hot.

The temperature range can be 275–300°F on average. Set your maximum temperature warning to go off if the engine exceeds 350°F. If your engine is continually near this peak temperature or higher, immediately decrease throttle to bring the temperature down. If this continues to occur, land the airplane and add additional baffling to your cowl. It is not good for the engine to run at temperatures this high and could cause damage if not attended to.

Starting and Operating the 15GX Engine

Now that you have the baseline needle valve settings, you are ready to start your engine for the first time. With the 15GX it is very important to allow the temperature to stabilize above 170°F (75°C) before making any adjustments; adjusting prior to the engine warming up will lead you to inaccurate settings. As the engine warms up you will notice the rpms naturally rising.

If you do not have a temp gun or have sensors installed on your engine, allow the engine to run at half throttle for at least 45 seconds before attempting to set the high-speed needle. If you have accurately set the low-speed needle as described you should not need to adjust it.

Priming

1. Make sure your ignition is off.
2. Open the throttle fully and, either by holding a finger over the carburetor intake or the muffler exhaust, flip the propeller 6 times.
3. Remove your finger from either the carburetor or muffler exhaust and flip the engine another 6 times.
4. Close the carburetor completely with your throttle stick and then open it two detents from closed. This will allow the engine to start at a high throttle setting.

Because each fuel system and installation is slightly different, you may find the need to modify the above procedure for your individual setup. The above procedure should work for most installations.

Starting and Running the Engine

Until the engine is broken in, use an electric starter to start the engine. Once it is fully broken in it can be started by hand, but it is easier and safer to start the engine with an electric starter.

1. Turn on the ignition.
2. Rotate the propeller in a backwards direction against compression.
3. Push the starter firmly against the nose cone and engage. The engine should start relatively quickly, within 1–2 seconds. Once the engine starts disengage the starter.

4. Let the engine run at mid-throttle for 45 seconds to stabilize the temperatures.
 - a. If the engine doesn't start quickly, disengage the starter. Continuously running the starter can flood the engine.
 - b. Check to make that fuel is moving through the carburetor system.
 - c. If the engine appears not to have any fuel, repeat the priming procedure above.
 - d. Repeat 1–4 of Starting and Running the Engine.

High-Speed Needle Adjustment

Because of the small amount of fuel actually needed for this engine, needle adjustments need to be made in small increments. It may take 5 seconds or more before you will notice a running change in your engine after making it. Be patient. **Use a tachometer, this is a very important part of properly setting your high-speed needle valve.**

The procedure below is for ground setting the needles prior to flight. The final adjustments need to be made after noting the performance in the air.

1. With engine started and warmed up, open the throttle fully and note the rpm. Listen to the engine.
 - a. If the engine occasionally mis-fires but maintains a fairly constant rpm after 5 seconds, your engine is rich. Reduce the throttle to idle and turn in (clockwise) the high-speed needle 2 clicks. Repeat this until the engine stops mis-firing.
 - b. If the engine does not mis-fire and the rpm steadily decreases from the highest rpm achieved when you opened the throttle, it is lean. Reduce the throttle to idle and open (counterclockwise) the high-speed needle 2 clicks. Repeat this until the engine maintains the rpm achieved when the throttle is wide open. Your goal here is to achieve a good transition between high and low speed, and that the high-speed rpm will be steady on the ground.

2. Fly your aircraft for the in-air testing.
 - a. During flight, if the engine seems to slow down or sag when climbing, your engine is running slightly lean. Land the airplane and open the high-speed needle valve 2 clicks and take-off again.
 - b. During flight, if you hear the engine mis-firing occasionally in level flight, this is an indication it is running too rich. Land the airplane and close the high-speed needle valve 2 clicks and take-off again.
 - c. Repeat the above process until your engine performance is steady and repeatable. This high-speed needle setting should not change more than $\pm 1-2$ clicks in the future when using the same propeller. If it does, something is wrong in the fuel delivery system and should be investigated.

If you are using onboard telemetry and have a temperature monitor on the head of your engine, your readings should be between 200°F (93°C) and 300°F (149°C). If you see consistent temperatures above 340°F (171°C) you should land your airplane and add baffling to your cowl in order to increase cooling to the engine. See the Telemetry section for information on the proper positioning of your sensor.

Low-Speed Needle Adjustment

If you have properly set the idle need, the low-speed setting should be within $1/16$ th of a turn from perfect. Remember we are talking about minute amounts of fuel going through the carburetor, any adjustments you now make to the idle needle should be very, very small.

Take into consideration the length in service (e.g. break-in time) and the size of propeller you are using. In the beginning, use a smaller propeller early in the break-in process. You will not be able to achieve an idle much below 2000 rpm. The larger the propeller, the lower your idle rpm will be, and the more broken in your engine is will allow a lower idle rpm (14 x 6 should be about 1800–2000 rpm).

Your engine will idle at low-speed needle settings from far too rich to far too lean without any damage, so the quality of the idle is not a good indicator of the proper low-speed needle settings. The transition from idle to full throttle will be used to determine the position of the low-speed needle.

1. With the engine started and warmed up, open the throttle fully then reduce to idle and note the rpm. Listen to the engine.
2. Let the engine idle for ten seconds and then rapidly advance the throttle to full open. One of three things will occur:
 - a. The engine responds instantaneously. Your low speed needle is set perfectly. Now use your throttle trim to achieve the lowest reliable idle.
 - b. The engine slowly accelerates to full throttle. This indicates the low speed needle is set two rich and that fuel is building up in the crankcase. Shut the engine off and lean (clockwise turn) the low speed idle screw by an amount equal to the thickness of the screwdriver blade you are using to make the adjustment. Restart the engine and repeat steps 1 and 2.
 - c. The engine stutters or stops on it way to full throttle. This indicates the low speed needle is set too lean. With the engine off, richen (counterclockwise turn) the low speed idle screw by an amount equal to the thickness of the screwdriver blade you are using to make the adjustment. Restart the engine and repeat steps 1 and 2.
3. Once you have achieved the instantaneous throttle transition, your low-speed needle is set perfectly. Now go back and recheck your high-speed needle valve setting. There is some interaction between the two needles so you might need to do this process (HS and LS needle setting) a couple of times. Patience here will reward you with an easy to use engine. Don't try to do this too quickly.
4. Once you have achieved the instantaneous throttle transition your low speed needle is set perfectly. It is possible that with a heavier-loaded propeller that you may need to richen the needle in order to attain a smooth, instantaneous response again, but using the above procedure should lead you to the proper setting everytime.

15GX Evolution Engines Specifications

Disp	Bore	Stroke	Weight	Crank K (ISO)	Cylinder	Propeller
15cc	27.8mm	24.9mm	31.1 oz	5/16-24	Single	14 x 6 @ 10,400 rpm

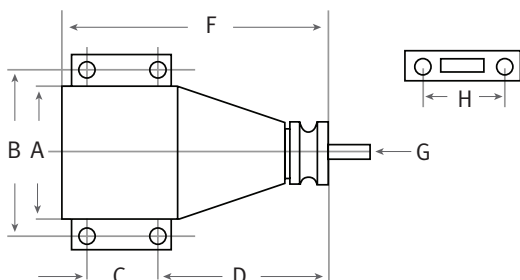

Weight

Engine Only	21.4 oz
Muffler	6.1 oz
Ignition	3.5 oz
Total	31.1 oz

E = Height*

F = Length

G = Crankshaft thread size

H = Muffler bolt spacing

Dimensions (mm)	A	B	C	D	E*	F	G	H
EVOE15GX	43	52	25	59	95	98.1	5/16 x 24	42

* Height is from engine C/L to top of cylinder head.

Troubleshooting Guide

If the Engine Does Not Start

- Check and use a new spark plug if needed.
- Check fuel lines.
- Check for proper mechanical function by turning the engine over.
- Check that the carburetor is correctly installed.
- Check that the muffler pressure line is attached and free from any bends or blockages.

Mechanical Faults

If the engine cannot be turned over easily

- The most likely cause is the engine is flooded and by turning the engine over you are trying to compress the fuel, not air.
 1. Remove the spark plug.
 2. Cover the cylinder head with a cloth or paper towel and turn the propeller over to expel all the excess fuel.
 3. Replace the spark plug and try starting again.

- A possible cause is the piston in the cylinder is seized: loosen and unscrew the cylinder head bolts.
 1. Carefully remove the cylinder liner.
 2. Visually examine the piston and cylinder to find the possible cause of the engine's mechanical problem.

Mechanical repairs must ALWAYS be completed by an authorized Horizon Hobby service center.

Maintenance

After each flying session:

1. Fully drain the fuel from the tank.
2. Start the engine and run it until the fuel is completely run out of the engine.
3. Try starting the engine three more times or until it will no longer fire. This gets all the fuel out of the engine.

If you need additional help or have any questions, please call Horizon's Support Team. Horizon has trained technicians who are qualified to answer your engine questions.

Exploded View

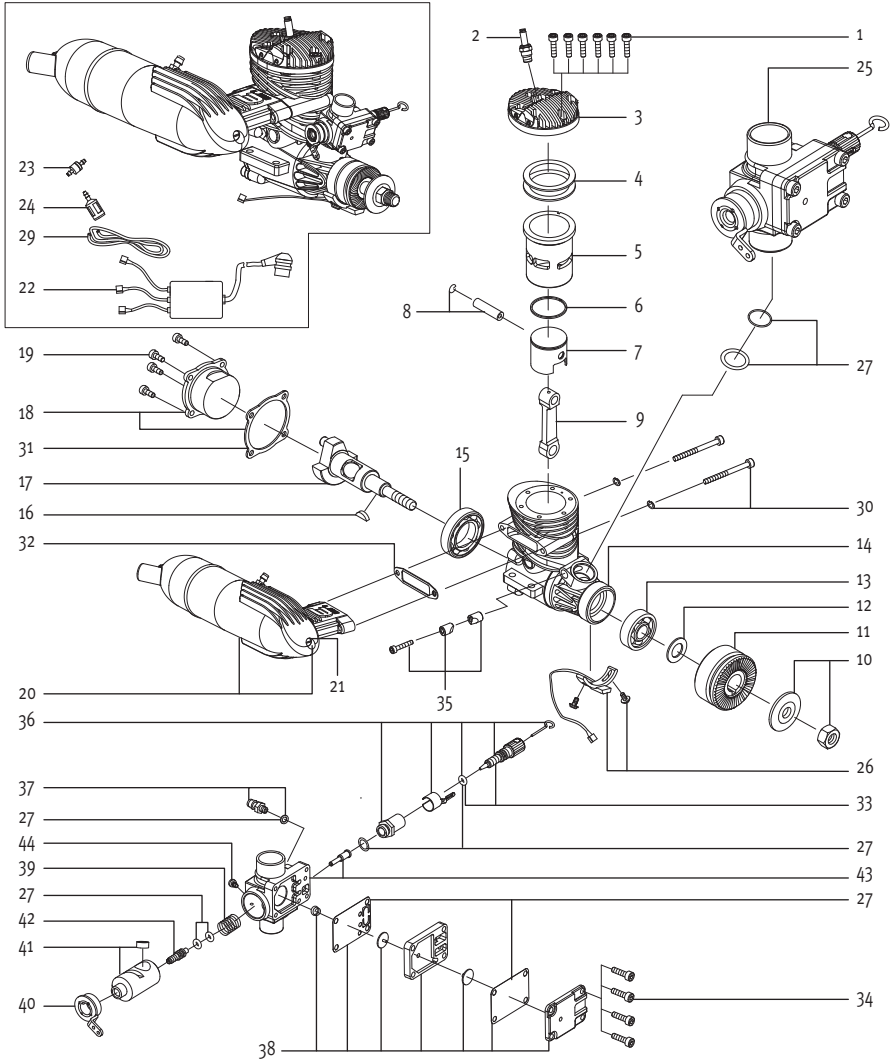

Parts List

#	Description	Part	#	Description	Part
1	Cylinder Screw (6)	EVO46408	24	In Tank Fuel Filter/Clunk	EVOA106
2	Spark plug	EVOG10350	25	Carb Assembly	EVOG15801
3	Cylinder Head	EVOG15103	26	Ignition Sensor Set	EVOG10310A
4	Cylinder Head Gasket (2)	EVO91112	27	Carb Gasket Set	EVOG15108A
5	Cylinder	EVOG15202	28	Carb Mount Gasket Set	EVOG61816A
6	Piston Ring	EVO91236	29	Medium Gas-FKM Fuel Tubing	EVOA102
7	Ringed Piston	EVOG15214	30	Muffler Mounting Screw Set	EVO9191A
8	Piston Pin & Retainer	EVO91213	31	Back Cover Gasket	EVO91111
9	Connecting Rod	EVOG15204	32	Muffler Gasket (2)	EVO91609
10	Prop Washer & Nut	EVO100228	33	High-Speed Needle	EVOG15829
11	Drive Washer	EVOG15219	34	Carb Regulator Screws (4)	EVOG12123
12	Spacer Washer	EVO91225	35	Carburetor Retainer	EVO61119
13	Front Bearing	EVO91109	36	High-Speed Needle Valve Assembly	EVOG15812
14	Crankcase with Index Pin	EVOG15101	37	Fuel Nipple-12114:A	EVO100114
15	Rear Bearing	EVO400110	38	Regulator Case Parts	EVOG1087A
16	Drive Key	EVO91218	39	Carb Barrel Spring	EVOG10814
17	Crankshaft	EVOG15210	40	Throttle Arm	EVO46866
18	Back Cover Set	EVOG15102	41	Throttle Barrel	EVOG15813
19	Back Cover Screw (4)	EVO40134	42	Low-Speed Adjustment	EVOG15844
20	Muffler Assembly	EVOG15601	43	Main Carb Body	EVOG15827
21	Muffler Long Screw	EVO91616	44	Carb Barrel Retaining Bolt	EVOG46825
22	Complete Ignition System	EVOG10300			
23	In Line Fuel Filter	EVOA105			

2-YEAR LIMITED WARRANTY

What this Warranty Covers - Horizon Hobby, Inc., (Horizon) warrants to the original purchaser that the product purchased (the "Product") will be free from defects in materials and workmanship for a period of 2 years from the date of purchase.

What is Not Covered - This warranty is not transferable and does not cover (i) cosmetic damage, (ii) damage due to acts of God, accident, misuse, abuse, negligence, commercial use, or due to improper use, installation, operation or maintenance, (iii) modification of or to any part of the Product, (iv) attempted service by anyone other than a Horizon Hobby authorized service center, (v) Product not purchased from an authorized Horizon dealer, or (vi) Product not compliant with applicable technical regulations. OTHER THAN THE EXPRESS WARRANTY ABOVE, HORIZON MAKES NO OTHER WARRANTY OR REP-

RESENTATION, AND HEREBY DISCLAIMS ANY AND ALL IMPLIED WARRANTIES, INCLUDING, WITHOUT LIMITATION, THE IMPLIED WARRANTIES OF NON-INFRINGEMENT, MERCHANTABILITY AND FITNESS FOR A PARTICULAR PURPOSE. THE PURCHASER ACKNOWLEDGES THAT THEY ALONE HAVE DETERMINED THAT THE PRODUCT WILL SUITABLY MEET THE REQUIREMENTS OF THE PURCHASER'S INTENDED USE.

Purchaser's Remedy - Horizon's sole obligation and purchaser's sole and exclusive remedy shall be that Horizon will, at its option, either (i) service, or (ii) replace, any Product determined by Horizon to be defective. Horizon reserves the right to inspect any and all Product(s) involved in a warranty claim. Service or replacement decisions are at the sole discretion of Horizon. Proof of purchase is required for all warranty claims. SERVICE OR REPLACEMENT AS PROVIDED UNDER THIS WAR-

RANTY IS THE PURCHASER'S SOLE AND EXCLUSIVE REMEDY.

Limitation of Liability - HORIZON SHALL NOT BE LIABLE FOR SPECIAL, INDIRECT, INCIDENTAL OR CONSEQUENTIAL DAMAGES, LOSS OF PROFITS OR PRODUCTION OR COMMERCIAL LOSS IN ANY WAY, REGARDLESS OF WHETHER SUCH CLAIM IS BASED IN CONTRACT, WARRANTY, TORT, NEGLIGENCE, STRICT LIABILITY OR ANY OTHER THEORY OF LIABILITY, EVEN IF HORIZON HAS BEEN ADVISED OF THE POSSIBILITY OF SUCH DAMAGES. Further, in no event shall the liability of Horizon exceed the individual price of the Product on which liability is asserted. As Horizon has no control over use, setup, final assembly, modification or misuse, no liability shall be assumed nor accepted for any resulting damage or injury. By the act of use, setup or assembly, the user accepts all resulting liability. If you as the purchaser or user are not prepared to accept the liability associated with the use of the Product, purchaser is advised to return the Product immediately in new and unused condition to the place of purchase.

Law - These terms are governed by Illinois law (without regard to conflict of law principals). This warranty gives you specific legal rights, and you may also have other rights which vary from state to state. Horizon reserves the right to change or modify this warranty at any time without notice.

WARRANTY SERVICES

Questions, Assistance, and Services - Your local hobby store and/or place of purchase cannot provide warranty support or service. Once assembly, setup or use of the Product has been started, you must contact your local distributor or Horizon directly. This will enable Horizon to better answer your questions and service you in the event that you may need any assistance. For questions or assistance, please visit our website at www.horizonhobby.com, submit a Product Support Inquiry, or call the toll free telephone number referenced in the Warranty and Service Contact Information section to speak with a Product Support representative.

Inspection or Services - If this Product needs to be inspected or serviced and is compliant in the country you live and use the Product in, please use the Horizon Online Service Request submission process found on our website or call Horizon to obtain a Return Merchandise Authorization (RMA) number. Pack the Product securely using a shipping carton. Please note that original boxes may be included, but are not designed to withstand the rigors of shipping without additional protection. Ship via a carrier that provides tracking and insurance for lost or damaged parcels, as Horizon is not responsible for merchandise until

it arrives and is accepted at our facility. An Online Service Request is available at http://www.horizonhobby.com/content/_service-center_render-service-center. If you do not have internet access, please contact Horizon Product Support to obtain a RMA number along with instructions for submitting your product for service. When calling Horizon, you will be asked to provide your complete name, street address, email address and phone number where you can be reached during business hours. When sending product into Horizon, please include your RMA number, a list of the included items, and a brief summary of the problem. A copy of your original sales receipt must be included for warranty consideration. Be sure your name, address, and RMA number are clearly written on the outside of the shipping carton.

NOTICE: Do not ship LiPo batteries to Horizon. If you have any issue with a LiPo battery, please contact the appropriate Horizon Product Support office.

Warranty Requirements - For Warranty consideration, you must include your original sales receipt verifying the proof-of-purchase date. Provided warranty conditions have been met, your Product will be serviced or replaced free of charge. Service or replacement decisions are at the sole discretion of Horizon.

Non-Warranty Service - Should your service not be covered by warranty, service will be completed and payment will be required without notification or estimate of the expense unless the expense exceeds 50% of the retail purchase cost. By submitting the item for service you are agreeing to payment of the service without notification. Service estimates are available upon request. You must include this request with your item submitted for service. Non-warranty service estimates will be billed a minimum of ½ hour of labor. In addition you will be billed for return freight. Horizon accepts money orders and cashier's checks, as well as Visa, MasterCard, American Express, and Discover cards. By submitting any item to Horizon for service, you are agreeing to Horizon's Terms and Conditions found on our website http://www.horizonhobby.com/content/_service-center_render-service-center.

ATTENTION: Horizon service is limited to Product compliant in the country of use and ownership. If received, a non-compliant Product will not be serviced. Further, the sender will be responsible for arranging return shipment of the un-serviced Product, through a carrier of the sender's choice and at the sender's expense. Horizon will hold non-compliant Product for a period of 60 days from notification, after which it will be discarded.

WARRANTY AND SERVICE CONTACT INFORMATION

Country of Purchase	Horizon Hobby	Contact Information	Address
United States of America	Horizon Service Center (Repairs and Repair Requests)	servicecenter.horizonhobby.com/RequestForm/	4105 Fieldstone Rd Champaign, Illinois, 61822 USA
	Horizon Product Support (Product Technical Assistance)	www.quickbase.com/db/bghj7ey8c?a=GenNewRecord 888-959-2305	
	Sales	sales@horizonhobby.com 888-959-2305	
United Kingdom	Service/Parts/Sales: Horizon Hobby Limited	sales@horizonhobby.co.uk +44 (0) 1279 641 097	Units 1-4, Ployters Rd, Staple Tye Harlow, Essex, CM18 7NS, United Kingdom
Germany	Horizon Technischer Service	service@horizonhobby.de	Christian-Junge-Straße 1 25337 Elmshorn, Germany
	Sales: Horizon Hobby GmbH	+49 (0) 4121 2655 100	
France	Service/Parts/Sales: Horizon Hobby SAS	infofrance@horizonhobby.com +33 (0) 1 60 18 34 90	11 Rue Georges Charpak 77127 Lieusaint, France
China	Service/Parts/Sales: Horizon Hobby – China	info@horizonhobby.com.cn +86 (021) 5180 9868	Room 506, No. 97 Changshou Rd. Shanghai, China 200060

COMPLIANCE INFORMATION FOR THE EUROPEAN UNION

CE Declaration of Conformity (in accordance with ISO/IEC 17050-1)

No. HH2013032704

Product(s): EVO 15cc (.91) Gas Engine

Item Number(s): EVOE15GX

The object of declaration described above is in conformity with the requirements of the specifications listed below, following the provisions of the European EMC Directive 2004/108/EC:

EN55022:2010 + AC:2011

EN55024:2010

Signed for and on behalf of:
Horizon Hobby, Inc.
Champaign, IL USA
March 27, 2013

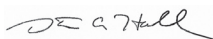

Steven A. Hall
Executive Vice President and Chief Operating Officer
International Operations and Risk Management
Horizon Hobby, Inc.



Instructions for disposal of WEEE by users in the European Union

This product must not be disposed of with other waste. Instead, it is the user's responsibility to dispose of their waste equipment by handing it over to a designated collections point for the recycling of waste electrical and electronic equipment. The separate collection and recycling of your waste equipment at the time of disposal will help to conserve natural resources and ensure that it is recycled in a manner that protects human health and the environment. For more information about where you can drop off your waste equipment for recycling, please contact your local city office, your household waste disposal service or where you purchased the product.



©2013 Horizon Hobby, Inc.

Evolution and the Horizon Hobby logo are registered trademarks of Horizon Hobby, Inc.

The Spektrum trademark is used with permission of Bachmann Industries, Inc.

Tygon® is a registered trademark of Saint-Gobain Performance Plastics Corporation.

All other trademarks, service marks and logos are the property of their respective owners.

Created 03/2013

32918