

# Evolution Engines 116GX

## USER GUIDE

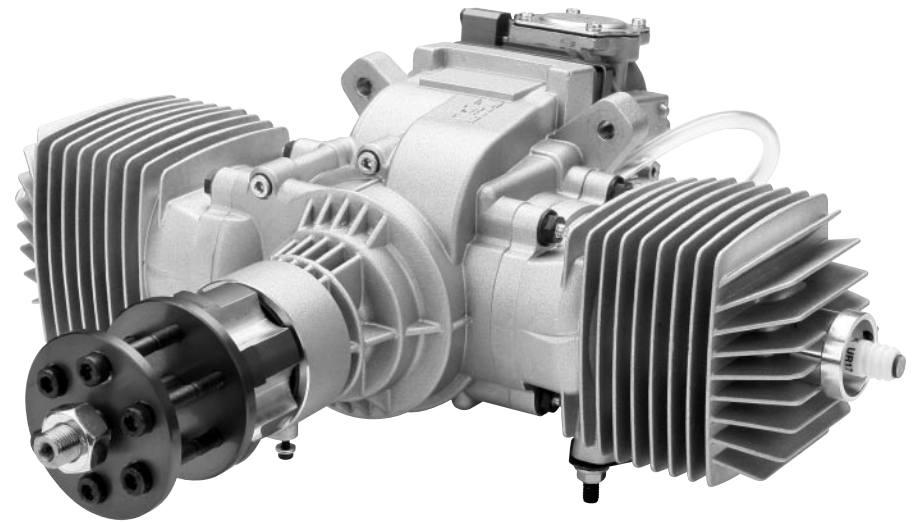

**HORIZON**  
H O B B Y

© 2005 Manufactured exclusively for Horizon Hobby, Inc.  
[www.horizonhobby.com](http://www.horizonhobby.com) 800-535-5551

8084



## Before using this engine, please read these instructions carefully.

### Introduction

Congratulations on your purchase of the newest and one of the most technically advanced 2-stroke gas model airplane engines in the world. Whether you are new to the sport of model aviation or an experienced flyer, you will enjoy the features of the new Evolution® GX engine. Evolution engines are designed to be the most powerful in their class, extremely easy to start and operate, and provide years of enjoyable service. These engines incorporate many unique features designed to ensure success with your new engine. This user's guide is intended to provide the basic information required to operate and maintain your Evolution GX engine.

**Important:** While the Evolution engine is extremely easy to operate, if this is your first experience flying a model airplane, it is highly recommended that you have the help of an experienced modeler during the first few flights. Your local hobby shop or flying club can put you in touch with an experienced pilot in your area.

### Evolution® Engines 2-Year Warranty

This Evolution Engines product is guaranteed to be free from defects in materials and workmanship for a period of 2 years from the date of purchase by the original owner. This warranty is not transferable. Horizon Hobby reserves the right to inspect any and all equipment involved in a warranty claim. Repair or replacement decisions are also determined by Horizon Hobby, Inc. Collateral damage of any type is not covered under this warranty.

This warranty does not cover any component parts damaged changed by modification. In no case shall Horizon Hobby or Evolution Engines liability exceed the original cost of the engine.

This warranty does not apply to wear from normal use; damage or defects resulting from misuse, neglect or abuse; damage caused by customer disassembly, use of substandard fuel, use of incorrect accessories (spark plug, propeller, etc.); or damage resulting from a crash or any use of this engine other than for which it is specifically intended. Any of the above will automatically void the warranty of the engine.

In that Horizon Hobby has no control over the final installation and use of this product, the materials used in installation or the product in which this engine is installed, no liability shall be assumed nor accepted for any damage resulting in

the use of this product once it is installed. By the act of using the installed product, the user accepts all resulting liability. If the buyer is not prepared to accept the liability associated with the installation and/or use of this product, the buyer is advised to return the engine immediately in new and unused condition to the place of purchase.

Should your engine require warranty or non-warranty repair service, please package it carefully and return it to the address below, along with a copy of the original invoice or receipt and a detailed letter explaining the problems. Write your name, address and daytime phone number clearly on the letter and return it via FedEx, UPS or insured Parcel Post (Evolution Engines will not be responsible for product lost en route).

For repairs not covered under warranty, please specify in your letter whether you want an estimate of the repair charges prior to performing the service (which may cause a slight delay). Payment for non-warranty repairs should be made by credit card or money order. If you have any questions concerning this or other Evolution products please contact the Horizon Product Support Team at 877-504-0233

**Evolution/Horizon Service Center**  
4105 Fieldstone Road, Champaign, IL 61822  
1-877-504-0233  
productsupport@horizonhobby.com

### Mounting the Engine

Most model airplane designs make provision for an engine mount. It is extremely important that the engine mount be securely attached to the airplane's firewall and that the engine is securely attached to the engine mount. Follow the instructions included with the airplane for mounting the engine. The engine should be fastened in place to the firewall with 4 screws. Use ¼" or 6mm screws. If you decide to fasten the engine using a flexible motor mount, always choose parts with enough solidity and strength. Make sure all screws are tightened and regularly check that they remain tight and in good condition.

**Important:** Air is necessary to cool the engine during operation. Make sure that sufficient air circulation through the cowling is provided.

### Throttle Linkage

Carefully attach the throttle linkage to the engine using a ball link on the carburetor. Make sure that the linkage is free to operate from low throttle to high throttle and confirm that low throttle setting on the transmitter closes the carburetor butterfly to the low idle position. Adjust the length of the pushrod until full throttle opens the throttle fully, while low-throttle, low trim completely closes the butterfly.

### Attaching the Fuel Lines

Use medium gasoline-compatible fuel line in the fuel tank as well as the supply line to the engine.

### Selecting a Suitable Propeller

The Evolution® 116GX has been designed to generate maximum power at 5800–6300 rpm, according to the type of exhaust used. If you wish to utilize the maximum power output, choose a propeller, which will allow the engine to reach these revolutions, or slightly lower revolutions (The engine will unload in the air depending on the aircraft speed and propeller selected).

### Suggested Propeller Dimensions

Two-blade propellers:  
28x10-14, 30x10-12, 32x10

We do not recommend using propellers that allow the engine to reach more than 7500 rpm on the ground.

### Control Jet System

Your engine is equipped with a unique system enabling improved acceleration from idle to high speed. This system allows the mixture to be controlled while the throttle valve is opening. It will lean the mixture at low rpm and at idle. Conversely the mixture will become richer as the throttle is opening. This system provides better acceleration to high speed and maintains a stable idle.

This system was developed for the Evolution 116cc engine. It is recommended that you do not change the mixture control leverage.

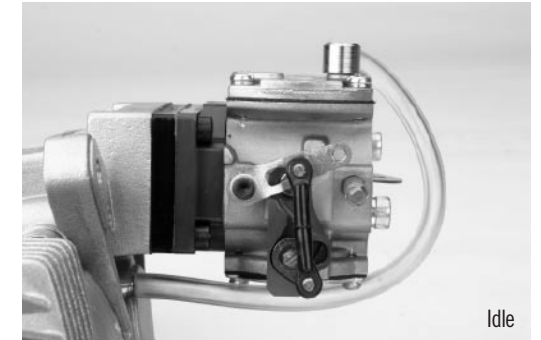

Idle

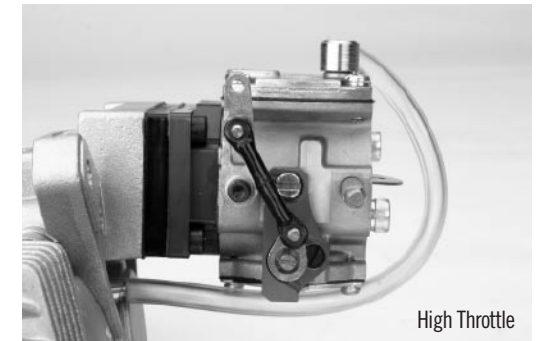

High Throttle

## Fuel for the Evolution Gas Engine

The Evolution® Gas engine has been designed to run on a mixture of high-quality unleaded gasoline and synthetic oil intended for racing 2-stroke gasoline engines. For the run-in period of the new engine, mix the fuel in a ratio of 30 parts gasoline to 1 part lubricant. After run-in, use a ratio of 40 parts gasoline to 1 part lubricant.

## Starting the Engine

The new Evolution Engine carburetor comes adjusted to a basic setting. This setting should be maintained during the initial break-in runs.

Before you first start the engine, make sure that the spark plug is screwed in and tightened and that the plug socket is fitted in place and fastened down properly. Fix the ignition sensor in the proper position above the magnet with the screws enclosed. Follow the directions in the Ignition System addendum to mount the ignition module in your model.

**Important:** *Never turn the engine over with the ignition turned on unless the spark plug is inserted in the plug socket. This could lead to ignition damage.*

1) When you are ready to start your engine, make sure that the ignition is switched off, the choke valve is closed and the throttle valve is partly open. Confirm that fuel is filling the fuel line to the carburetor then switch the ignition to the on position. Flip the propeller smartly until the engine fires. With the choke in the closed position, the engine will fire then quit.

2) Open the choke valve and set the throttle at a slightly high idle position. Be sure to have a helper hold the model securely. Give the propeller a few quick flips. When the engine starts, allow it to idle for 30-45 seconds in order for it to warm up to operating temperature. At this point you can proceed to test the carburetor settings before flying your model. See the following section regarding carburetor adjustment.

3) If the engine does not start, leave the throttle at the high idle position, turn the ignition off, then on and close the choke valve. Start the engine with throttle at the fast idle position and the choke valve closed. The engine should fire and quit. If it does, repeat step 2 above.

4) At this point, if the engine still will not start, unscrew the spark plugs and check the contacts. Clean any possible excess fuel (i.e. an indication of engine flooding) and screw them in again. Further starting should only be done with the throttle at idle position and the choke in the open position. If the plug is dry, then probably not enough fuel has been drawn into the carburetor. If that is the case, check for proper fuel feed and then return to the instructions given in paragraph 1.

Having started the engine, leave it running for about 5 minutes at a higher idle speed. Then run it for about 20 minutes, while changing revolutions from idle to 1/2-3/4 of the range and shortly holding each position—gradually prolong the holding periods. After 10 minutes of operation, open the throttle to maximum for a period of about one minute. At this point, stop the engine and let it cool

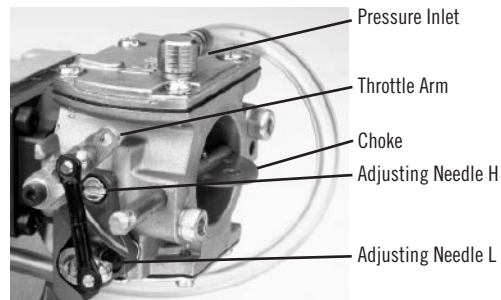

*Basic setting: throttle closed*

### Carburetor Adjustments

Adjust needle (L) for low rpm range 3/4 turn open  
Adjust needle (H) for high rpm 1 turn open

## Starting the Engine Continued

down. Then restart it and check the adjustment. If everything is all right, you can make your first flight. During the first few flights, do not overload the engine and do not let it run at high revolutions for long periods of time (very important during hot weather). Use up all the fuel that was mixed with the oil that is included with your engine. From then on, fuel and oil should be mixed in the proportion 40:1. First, start and warm the engine for 30-45 seconds before attempting to adjust the carburetor. In order to confirm that your engine is properly adjusted you should follow the procedure below.

## Carburetor Adjustment

1) Move the throttle from idle to 2/3 of the full throttle position quickly (fast acceleration). Then repeat three times – if the engine accelerates smoothly go to step 3 below. If acceleration is not smooth, go on to step 2.

2) Faulty acceleration and a tendency to quit is usually attributable to a poor fuel mixture in the medium rpm range. Stop the engine and recheck the fuel feed (the fuel line must not be pinched or broken). Restart the engine and test acceleration again. If the problem persists, adjust the carburetor. Open the low speed needle by 1/8 turn and retest. If acceleration is smooth, open the needle by another 1/8 turn—this should be done because the needle was previously set too lean; if atmospheric conditions have changed recently you may have to readjust the needle. If the engine continues to not accelerate properly, open the low speed needle by 10 minutes. If the engine's operation does not improve, shut it off and check the basic setting, restart the engine and test the acceleration. If the engine runs correctly, go to step 3. If it continues to not accelerate properly, open the low speed needle by another 10 minutes. If acceleration is faulty, the defect is likely to lie somewhere other than an incorrect adjustment.

3) If the engine accelerates correctly, according to the above test, set it at idle speed and accelerate to full speed. Repeat twice more. If the engine functions correctly, go to step 4. If it cuts out, open the low speed needle by another 1/8 turn more.

4) If the engine reacts correctly set it at full speed. If revolutions do not drop, the engine has been adjusted successfully. If revolutions seem to drop, open the high-speed needle by approx. 5-10 minutes.

**Caution!** *The engine must be stopped while you adjust the carburetor in order to prevent injury by the propeller.*

## Troubleshooting Guide

### If the engine does not start

- check and use a new spark plug if needed.  
(Check the spark: put the plug into the cable end and by turning the engine you'll see the necessary spark. Note: The plug must touch a metal part of the engine.)
- check fuel lines.
- check for proper mechanical function by turning the engine over.
- check that the carburetor is correctly installed.
- remove the carburetor cover from the feed side; check the filter and blow off carburetor with compressed air  
**(Caution: When using compressed air, use eye protection.);** when re-assembling be careful to maintain the proper order of the components.
- check the vacuum feed line.

### Mechanical Faults

If the engine can not be turned over easily

- a likely cause is the piston in the cylinder is seized: loosen and unscrew the cylinder bolts.
- carefully remove the cylinder.
- visually examine the piston and crankcase to find the likely cause of the engine's mechanical problem.

Note: Mechanical repairs must always be completed by a professional service department.

### Replacing the reed valve:

- Loosen carb screws and remove the carburetor (be careful not to damage the gasket)
- Loosen four M4 screws on the flange, remove the flange and take off the reed valve (be careful to not damage the gasket)
- Loosen four M2 screws and remove the old valves, replace them with new ones, replace all screws and tighten gently
- Be sure the gaskets are in their proper places.

## 116GX Evolution Engine Dimensions

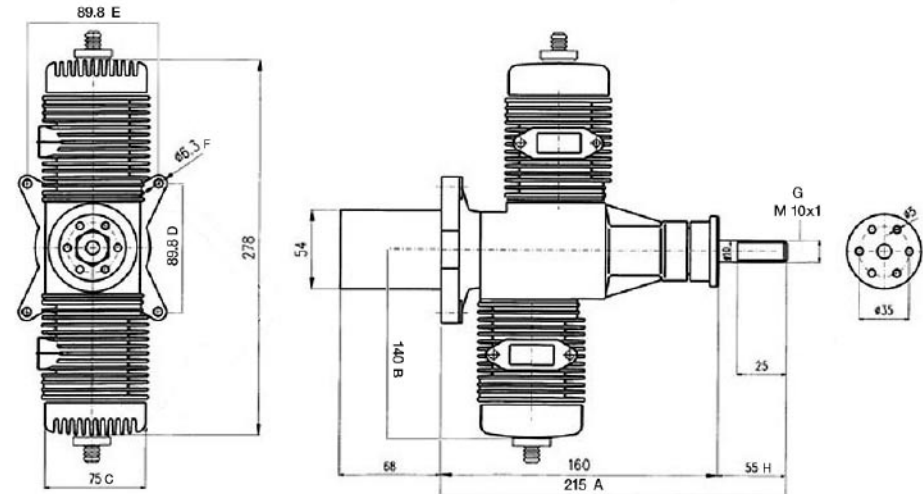

| A     | B     | C    | D      | E      |
|-------|-------|------|--------|--------|
| 215mm | 140mm | 75mm | 89.8mm | 89.8mm |

## 116GX Evolution Engine Specifications

|                          |                   |                        |                                   |
|--------------------------|-------------------|------------------------|-----------------------------------|
| Bore                     | 42mm              | Maximum power output** | 14 hp / 6400 rpm                  |
| Stroke                   | 42mm              | Maximum torque**       | 15N/m / 6100 rpm                  |
| Displacement             | 116cc / 7.1 cu in | Fuel                   | Unleaded high-octane gas          |
| Weight without ignition* | 3100 g / 6.8 lb   | Lubrication            | Oil w/gasoline<br>in mixture 1:40 |
| Weight of ignition unit  | 270 g / .6 oz     |                        |                                   |
| rpm range                | 1000–7500 rpm     |                        |                                   |

\* The value in the table above stands for the weight of a completely assembled engine, including the spark plug, carburetor, drive washer and prop screws.

\*\* Power output varies with the exhaust used. The value given in the table stands for the maximum available power output.

## Evolution GX Engine Ignition System

The spark ignition included with your Evolution® Gas engine is a modern generation electronic ignition. It will provide excellent operation for a long time if used correctly. Here are some features that you should be aware of.

In addition to the basic ignition functions, the unit has two safety features.

1. After 90 seconds of inactivity it automatically switches to an inactive state. In order to restart normal operation it is necessary to turn the battery switch off and then back on. This function will preserve battery life should the switch be left in the on position during inactivity.
2. During normal operation the battery voltage will decrease. When the voltage reaches 4.4V the ignition unit will limit maximum rpm in the range of 3000–4000 rpm. This is an indication to land the model as soon as practical.

## Installation of the Ignition Unit

The electronic ignition unit requires a 4.8-volt battery source separate from your model's radio system. A 600mAH battery will provide more than 1.5 hours of operation. The supplied battery connector is compatible with the JR® radio battery connector.

While installing the ignition unit in your model, be careful to have all parts that are connected to the unit and the engine situated as far as practical from the radio receiver and radio antenna. The throttle servo should be mounted a distance of 8–12 inches from the engine. The spark plug cable must not touch any part of the model structure, as vibration may damage the cable. If this is not practical, it will be necessary to provide an insulation material for the cable. The ignition unit itself should be wrapped in foam rubber to prevent engine vibration from damaging the electronics. All components must be protected from contact with engine fuel.

## Installation of the Ignition Unit Continued

| Technical data      |                                      |
|---------------------|--------------------------------------|
| Battery Supply      | 4.8–6 Volts                          |
| Current Consumption | 90–120mAh at Idle<br>500mAh/9000 rpm |
| Plug Voltage        | 18Kv                                 |
| Weight              | 265 g                                |
| Dimension           | 55x50x25mm                           |
| Sensor Magnet Space | max. 0.5mm (.020")                   |
| Plug Spark Gap      | .6mm (.025")                         |
| Working Temperature | -10 to 85 deg C                      |

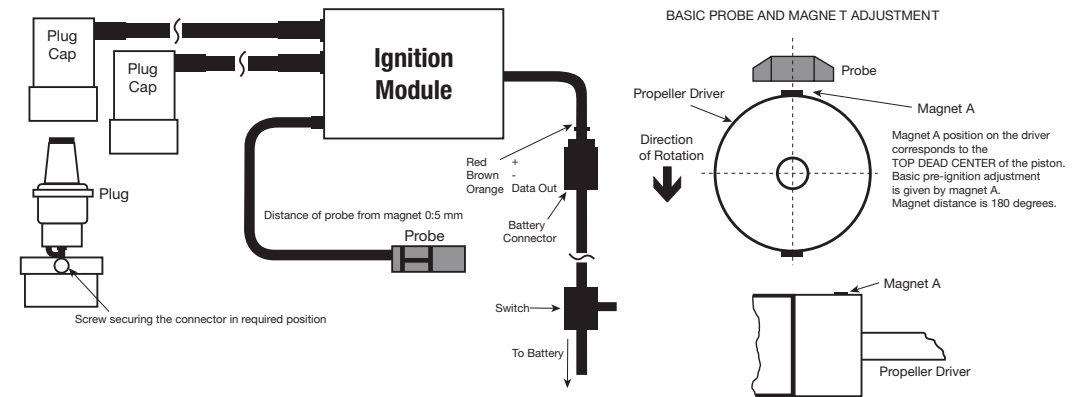

## 116GX Parts Diagram

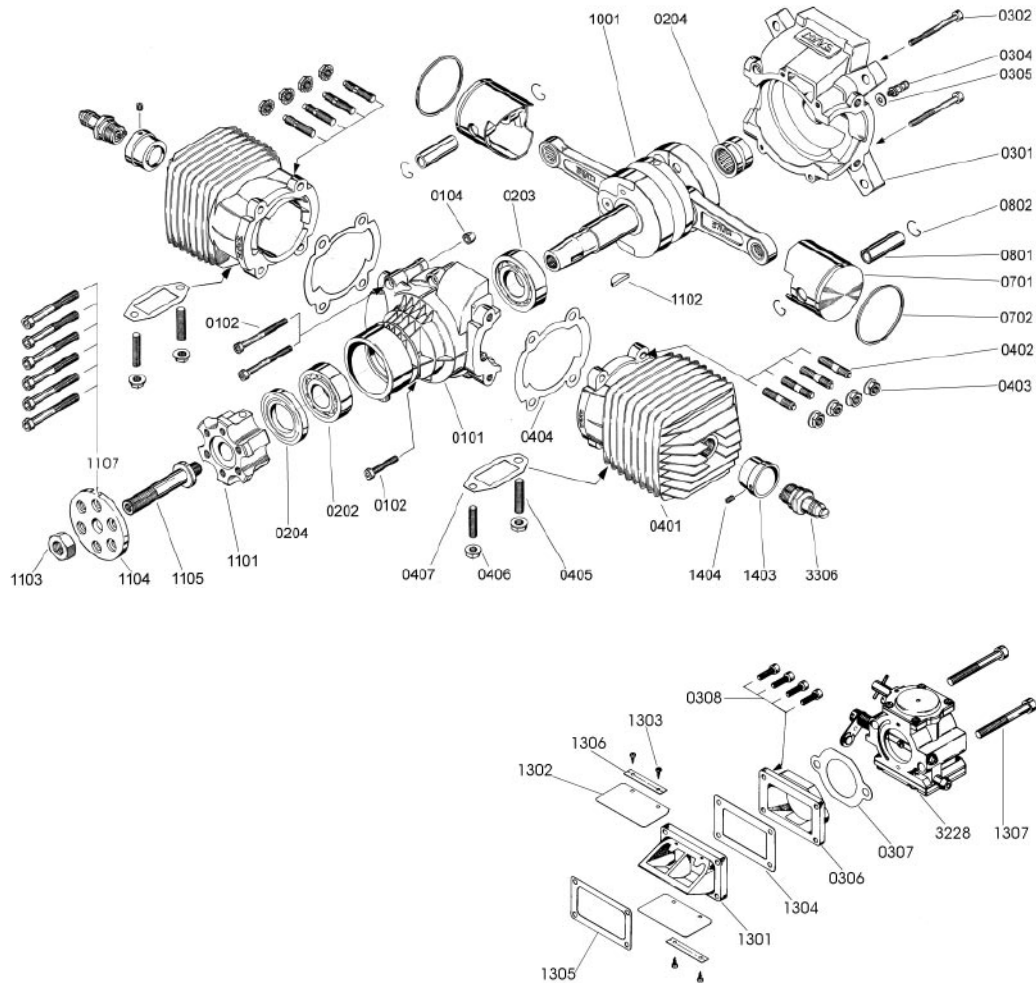

## 116GX Parts List

| Part Number | Description            | Part Number | Description                   |
|-------------|------------------------|-------------|-------------------------------|
| EV030100101 | Crankcase              | EV030101101 | Drive Washer                  |
| EV030100102 | Crankcase Screws Set   | EV030101102 | Drive Washer Key              |
| EV030100202 | Front Bearing          | EV030101103 | Propeller Nut                 |
| EV030100204 | Packing                | EV030101104 | Propeller Washer              |
| EV030100203 | Rear Bearing           | EV030101105 | Propeller Screw               |
| EV030100301 | Rear Cover             | EV030101107 | Propeller Screws Set          |
| EV030100302 | Rear Cover Screws Set  | EV030100306 | Carburetor Flange             |
| EV030940304 | Pressure Nipple        | EV030100307 | Carburetor Flange Gasket      |
| EV030100305 | Pressure Nipple Gasket | EV030100308 | Carburetor Flange Screws Set  |
| EV030100401 | Cylinder               | EV030101301 | Reed Valve Case               |
| EV030100402 | Cylinder Screws Set    | EV030101302 | Reed Valve                    |
| EV030100403 | Cylinder Nut           | EV030101303 | Reed Valve Screws             |
| EV030100404 | Cylinder Gasket        | EV030101304 | Reed Valve Gasket-upper       |
| EV030100405 | Exhaust Screws Set     | EV030101305 | Reed Valve Gasket-bottom      |
| EV030100406 | Exhaust Nut            | EV030101306 | Reed Valve Strap              |
| EV030100407 | Exhaust Flange Gasket  | EV030101307 | Carburetor Screws             |
| EV030100701 | Piston                 | EV030103313 | Electric Ignition Unit        |
| EV030100702 | Piston Ring            | EV03306     | Spark Plug                    |
| EV030100801 | Piston Pin             | EV030941403 | Spark Plug Washer             |
| EV030100802 | Piston Pin Retainer    | EV030941404 | Locking Screw                 |
| EV030100901 | Connecting Rod         | EV030941405 | Ignition Sensor Fixing Screws |
| EV030100904 | Connecting Rod Washer  | EV030100802 | Reed Valve Assembly           |
| EV030101001 | Crankshaft             | EV030103328 | Carburetor Complete           |