

# **boost™**

**1/10 ELECTRIC BUGGY**

**ECX3000S | ECX3000SA | ECX3000SEU  
ECX3100S | ECX3100SA | ECX3100SEU**

**INSTRUCTION MANUAL  
BEDIENUNGSANLEITUNG  
MANUEL D'UTILISATION  
MANUALE**

Congratulations on your purchase of the ECX™ Boost™ Buggy. This 1/10-scale model introduces you to the sport of RC driving.

Herzlichen Glückwunsch zum Kauf des ECX Boost Buggy. Dieses 1/10 Scale Model öffnet Ihnen die Welt des RC Car Sports.

Nous vous félicitons pour l'achat du ECX Boost Buggy. Ce modèle 1/10 vous introduit au sport de la conduite RC.

Congratulazioni per l'acquisto di questo Boost Buggy ECX. Questa vettura in scala 1/10 vi introdurrà nel mondo dei modelli RC.

## NOTICE

All instructions, warranties and other collateral documents are subject to change at the sole discretion of Horizon Hobby, Inc. For up-to-date product literature, visit <http://www.horizonhobby.com> and click on the support tab for this product.

### Meaning of Special Language:

The following terms are used throughout the product literature to indicate various levels of potential harm when operating this product:

**NOTICE:** Procedures, which if not properly followed, create a possibility of physical property damage AND little or no possibility of injury.

**CAUTION:** Procedures, which if not properly followed, create the probability of physical property damage AND a possibility of serious injury.

**WARNING:** Procedures, which if not properly followed, create the probability of property damage, collateral damage, and serious injury OR create a high probability of superficial injury.



**WARNING:** Read the ENTIRE instruction manual to become familiar with the features of the product before operating. Failure to operate the product correctly can result in damage to the product, personal property and cause serious injury.

This is a sophisticated hobby product and NOT a toy. It must be operated with caution and common sense and requires some basic mechanical ability. Failure to operate this Product in a safe and responsible manner could result in injury or damage to the product or other property. This product is not intended for use by children without direct adult supervision. Do not attempt disassembly, use with incompatible components or augment product in any way without the approval of Horizon Hobby, Inc. This manual contains instructions for safety, operation and maintenance. It is essential to read and follow all the instructions and warnings in the manual, prior to assembly, setup or use, in order to operate correctly and avoid damage or serious injury.

**Age Recommendation: Not for children under 14 years. This is not a toy.**

### Safety Precautions and Warnings

As the user of this product, you are solely responsible for operating in a manner that does not endanger yourself and others or result in damage to the product or property of others.

This model is controlled by a radio signal subject to interference from many sources outside your control. This interference can cause momentary loss of control, so it is advisable to always keep a safe distance in all directions around your model as this margin will help avoid collisions or injury.

- Never operate your model with low transmitter batteries.
- Always operate your model in an open area away from cars, traffic or people.
- Never operate the model in the street or in populated areas for any reason.
- Carefully follow the directions and warnings for this and any optional support equipment (chargers, rechargeable battery packs, etc.) you use.

- Keep all chemicals, small parts and anything electrical out of the reach of children.
- Never lick or place any portion of the model in your mouth as it could cause serious injury or even death.
- Exercise caution when using tools and sharp instruments.
- Take care during maintenance as some parts may have sharp edges.
- Immediately after using your model, do NOT touch equipment such as the motor, electronic speed control and battery, because they generate high temperatures. You may burn yourself seriously touching them.
- Do not put fingers or any objects inside rotating and moving parts, as this may cause damage or serious injury.
- Always turn on your transmitter before you turn on the receiver in the car. Always turn off the receiver before turning your transmitter off.
- Keep the wheels of the model off the ground when checking the operation of the radio equipment.

## TABLE OF CONTENTS

Specifications.....	3	Motor Care .....	8
Components .....	4	Maintenance.....	9
Vehicle Preparations.....	4	Setting the Gear Mesh .....	9
Charging the Vehicle Battery.....	4	Electronic Speed Control (ESC).....	9
Charging Warnings and Precautions .....	4	Electrical Layout .....	10
Installing Transmitter Batteries.....	5	Shock Cleaning.....	10
Transmitter Battery Safety Precautions.....	5	Fasteners.....	11
Removing the Vehicle Body .....	5	Binding.....	11
Installing the Battery in the Vehicle .....	5	Troubleshooting Guide .....	12
Transmitter Controls .....	6	Limited Warranty .....	12
Getting Started .....	7	FCC Information .....	13
Installing the Vehicle Body.....	7	Compliance Information for the European Union.....	14
Operation.....	8	Parts Diagram.....	52
When You Are Finished.....	8		

## WATER-RESISTANT VEHICLE WITH WATERPROOF ELECTRONICS

Your new Horizon Hobby vehicle has been designed and built with a combination of waterproof and water-resistant components to allow you to operate the product in many “wet conditions”, including puddles, creeks, wet grass, snow and even rain.

While the entire vehicle is highly water-resistant, it is not completely waterproof and your vehicle should NOT be treated like a submarine. The various electronic components used in the vehicle, such as the Electronic Speed Control (ESC), servo(s) and receiver are waterproof, however, most of the mechanical components are water-resistant and should not be submerged.

Metal parts, including the bearings, hinge pins, screws and nuts, as well as the contacts in the electrical cables, will be susceptible to corrosion if additional maintenance is not performed after running in wet conditions. To maximize the long-term performance of your vehicle and to keep the warranty intact, the procedures described in the “Wet Conditions Maintenance” section below must be performed regularly if you choose to run in wet conditions. If you are not willing to perform the additional care and maintenance required, then you should not operate the vehicle in those conditions.



**CAUTION:** Failure to exercise caution while using this product and complying with the following precautions could result in product malfunction and/or void the warranty.

### General Precautions

- Read through the wet conditions maintenance procedures and make sure that you have all the tools you will need to properly maintain your vehicle.
- Not all batteries can be used in wet conditions. Consult the battery manufacturer before use. Do not use Li-Po batteries in wet conditions.
- Most transmitters are not water-resistant. Consult your transmitter’s manual or the manufacturer before operation.
- Never operate your transmitter or vehicle where lightning may be present.
- Do not operate your vehicle where it could come in contact with salt water (ocean water or water on salt-covered roads), contaminated or polluted water. Salt water is very conductive and highly corrosive, so use caution.
- Even minimal water contact can reduce the life of your motor if it has not been certified as water-resistant or waterproof. If the motor

becomes excessively wet, apply very light throttle until the water is mostly removed from the motor. Running a wet motor at high speeds may rapidly damage the motor.

- Driving in wet conditions can reduce the life of the motor. The additional resistance of operating in water causes excess strain. Alter the gear ratio by using a smaller pinion or larger spur gear. This will increase torque (and motor life) when running in mud, deeper puddles, or any wet conditions that will increase the load on the motor for an extended period of time.

### Wet Conditions Maintenance

- Drain any water that has collected in the tires by spinning them at high speed. With the body removed, place the vehicle upside down and pull full throttle for a few short bursts until the water has been removed.



**CAUTION:** Always keep hands, fingers, tools and any loose or hanging objects away from rotating parts when performing the above drying technique.

- Remove the battery pack(s) and dry the contacts. If you have an air compressor or a can of compressed air, blow out any water that may be inside the recessed connector housing.
- Remove the tires/wheels from the vehicle and gently rinse the mud and dirt off with a garden hose. Avoid rinsing the bearings and transmission.

**NOTICE:** Never use a pressure washer to clean your vehicle.

- Use an air compressor or a can of compressed air to dry the vehicle and help remove any water that may have gotten into small crevices or corners.
- Spray the bearings, drive train, fasteners and other metal parts with WD-40® solvent or any other water-displacing light oil. Do not spray the motor.
- Let the vehicle air dry before you store it. Water (and oil) may continue to drip for a few hours.
- Increase the frequency of disassembly, inspection and lubrication of the following:
  - Front and rear axle hub assembly bearings.
  - All transmission cases, gears and differentials.
  - Motor—clean with an aerosol motor cleaner and re-oil the bushings with lightweight motor oil.

## SPECIFICATIONS

### Transmitter

Frequency	2.4GHz
Battery	AA x 4

### Servo

Power Supply	4.8V–6V (shared with receiver)
Output Torque	41.66 oz (3 kg-cm) at 6V
Operating Speed	0.20 sec/60 degrees of travel
Size	55.6 x 20 x 43.2mm

### Electronic Speed Control (ESC)

Input Voltage	4.9–8.4V
Electric Capacity (FET)	Forward 38 A cont./380 A peak
Electric Capacity (FET)	19 A cont./190 A peak
PWM Frequency	1kHz
BEC Voltage	5.6V/1 A max at 7.2V
Size (L x W x H)	66.8 x 57.6 x 48.3mm
Weight	72 g

## COMPONENTS

1. ECX™ Boost™ 1/10-scale Buggy
2. ECX™ 2.4GHz Transmitter
3. AA (4) Batteries
4. 2A Peak Battery Charger (DYN4113)
5. Dynamite® Speedpack™ 7.2V Ni-MH battery (DYN1050EC)

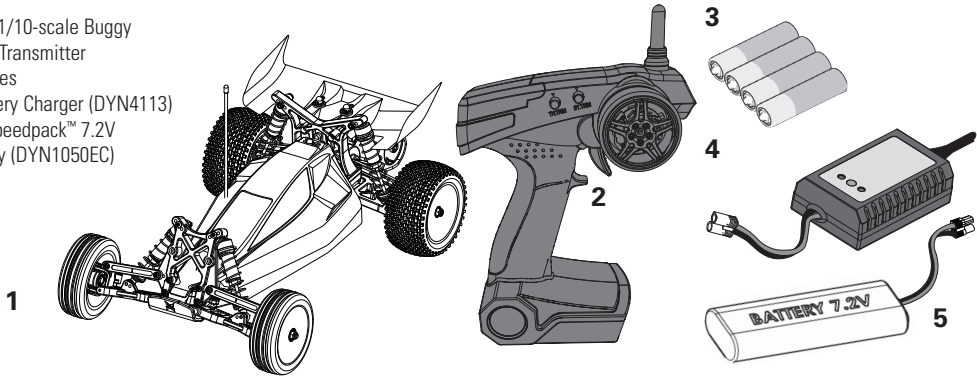

## VEHICLE PREPARATIONS

### CHARGING THE VEHICLE BATTERY

1. Connect the AC power cord to the power slot on the charger, then connect the other end of the power cord to an AC power source.
2. The Power LED and Charging LED will turn GREEN when the charger is connected to the AC power source.
3. Connect the battery pack connector to the charge connector.
4. Press the On/Off button to charge the battery. The Charging LED turns RED.
5. When the battery pack is fully charged, the Charging LED will turn GREEN.
6. Press the On/Off button to stop charging. Disconnect the battery pack connector from the charge connector.



**CAUTION:** If at any time during the charge process the battery pack(s) becomes hot to the touch, unplug the battery immediately and discontinue the charge process.

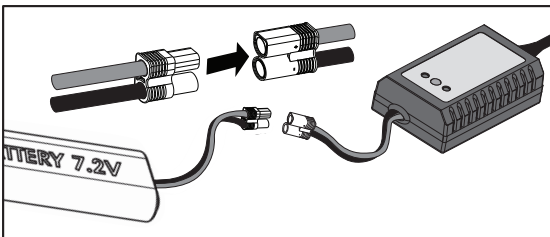

The vehicle battery charger produces 2000 milliAmps (2 Amps) per hour. Divide the mAh capacity on the label of a battery by 2000 to know how long battery charging will require. For example, an 1800mAh battery requires 0.9 hours (54 minutes) to charge.

### CHARGING WARNINGS AND PRECAUTIONS

- Read all safety precautions and literature prior to use of this product.
- Never allow minors to charge battery packs.
- Never attempt to charge dead or damaged batteries.
- Never charge a battery if the cable has been pinched or shorted.
- Never allow batteries or chargers to come into contact with moisture at any time.
- Never charge batteries in extremely hot or cold places (recommended between 50–80°F or 10–26°C) or place in direct sunlight.
- Always use only Ni-MH rechargeable batteries. This charger cannot charge batteries such as "heavy duty", "alkaline", "mercury" or "lithium" battery.
- Always connect the positive red lead (+) and negative black lead (-) terminals of the battery to the charger terminals correctly.
- Always disconnect the battery and charger after charging and let them cool between charges.
- Always inspect the battery before charging.
- Always terminate all processes and contact Horizon Hobby if the product malfunctions.
- Always make sure you know the specifications of the battery to be charged or discharged to ensure it meets the requirements of this charger.
- Never connect more than one battery pack to this charger at a time.
- Always constantly monitor the temperature of the battery pack while charging.
- Always end the charging process if the charger or battery becomes hot to the touch or starts to change form during the charge process.

## INSTALLING TRANSMITTER BATTERIES

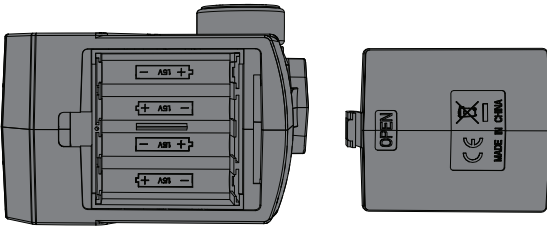

**CAUTION:** If using rechargeable batteries, charge only rechargeable batteries. Charging non-rechargeable batteries may cause the batteries to burst, resulting in injury to persons and/or damage to property.

NEVER install damaged batteries, batteries of mixed types or batteries of different ages in the transmitter. Remove exhausted batteries.

NEVER store the transmitter with batteries installed.

Install 4 AA alkaline batteries into the transmitter, following the instructions provided for your radio system.

We recommend using only alkaline AA batteries in the transmitter, however, it is possible to use rechargeable Ni-MH batteries.

## TRANSMITTER BATTERY SAFETY PRECAUTIONS

- Never install damaged batteries.
- Never install batteries of mixed types or of different ages in the transmitter.
- Always remove exhausted batteries.
- Always remove batteries before storing the transmitter.
- Low battery power can result in loss of control of the RC vehicle.

## REMOVING THE VEHICLE BODY

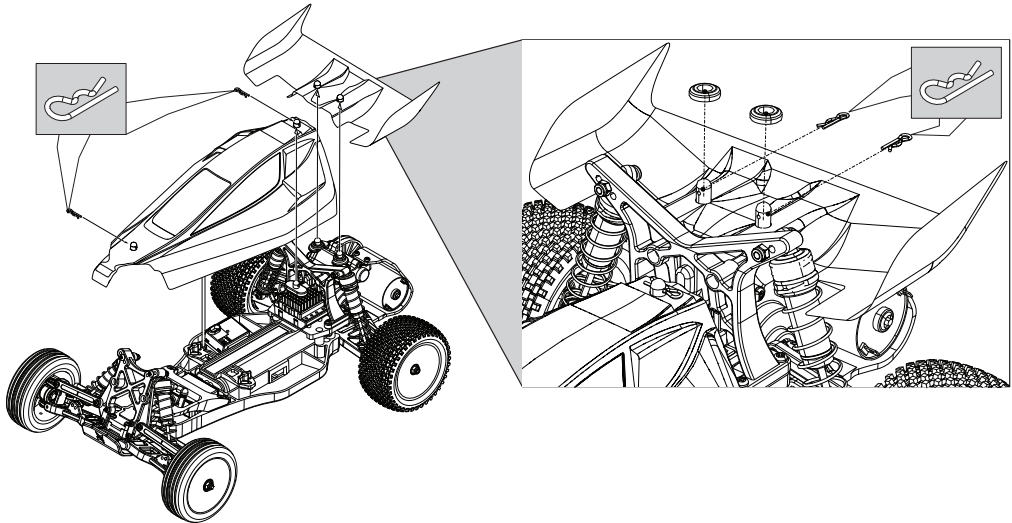

## INSTALLING THE BATTERY IN THE VEHICLE

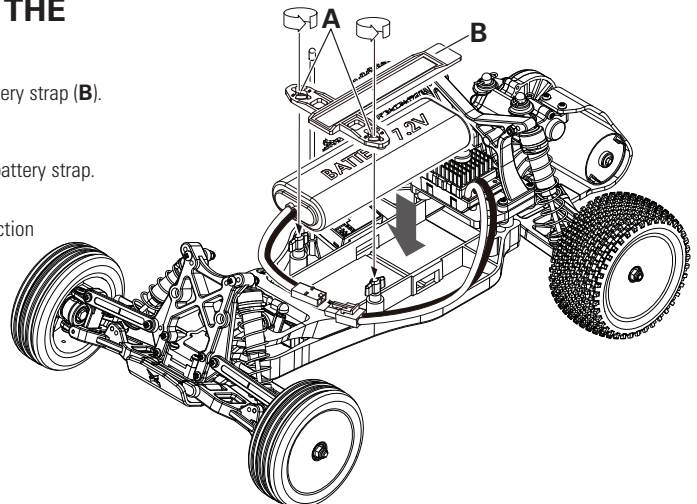

1. Turn the battery clips (A) clockwise to remove the battery strap (B).
2. Install a fully charged battery.
3. Install the battery strap.
4. Turn the battery clips counterclockwise to secure the battery strap.

If desired, you can put foam blocks (ECX2015) in front of the battery so the weight of the battery increases rear traction or in back of the battery to increase steering response.



# TRANSMITTER CONTROLS

## Battery Level Indicator

-  Solid Red and Green: Battery voltage is good (Above 4V).
-  Solid Red: Battery voltage is critically low (below 4V). Replace transmitter batteries.

## Reverse Switch



Allows you to change the direction of steering (ST. REV) and throttle (TH. REV) controls. (Default setting for steering and throttle is "REV")

## Throttle Dual Rate

-  Adjusts the maximum amount of throttle the vehicle can be given

## Power Switch

Power on or off the transmitter

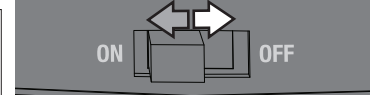

## Steering Rate

-  Adjusts the amount the front wheels move when the steering wheel is turned left or right

## Steering Wheel

-  Control steering. Right and Left steering with ST. REV Switch on REV (See Reverse Switch)

## Throttle Trim

-  Adjusts the neutral point of the electronic speed control

## Steering Trim

-  Adjust to make the vehicle drive straight with no input at the steering wheel

## Throttle Trigger

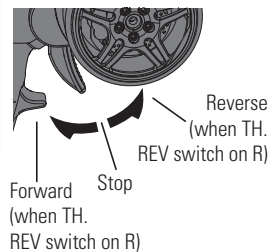

Controls power to the motor for forward or reverse (See TH. REV switch)

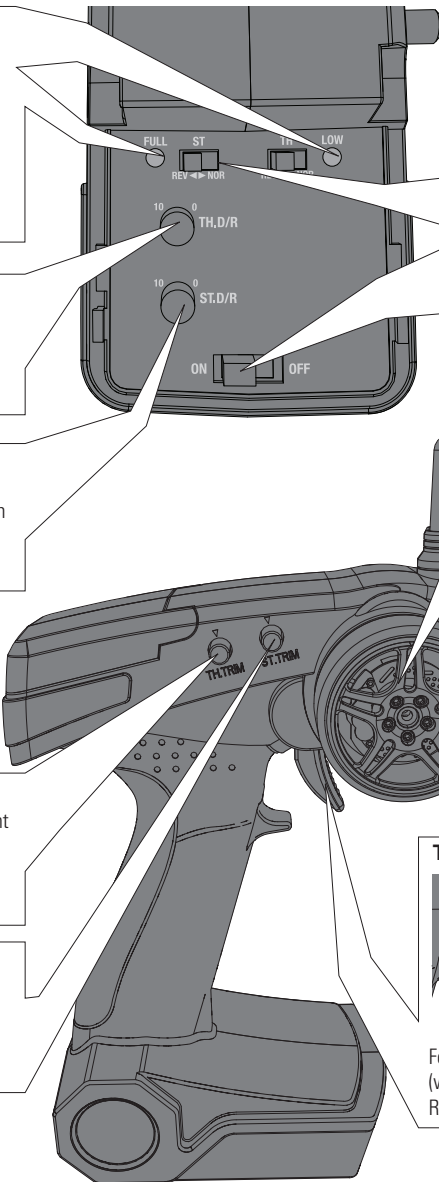

## GETTING STARTED

1. Power on the transmitter.

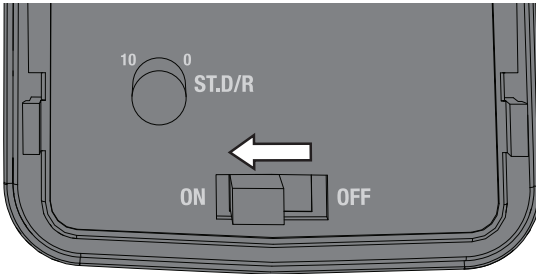

2. Power on the ESC.

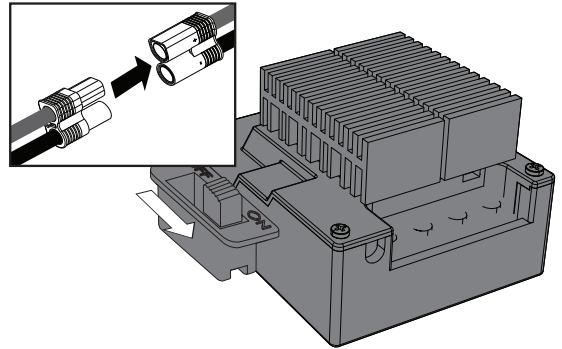

3. Do a test of the transmitter's control of the vehicle with the vehicle's wheels off the ground.

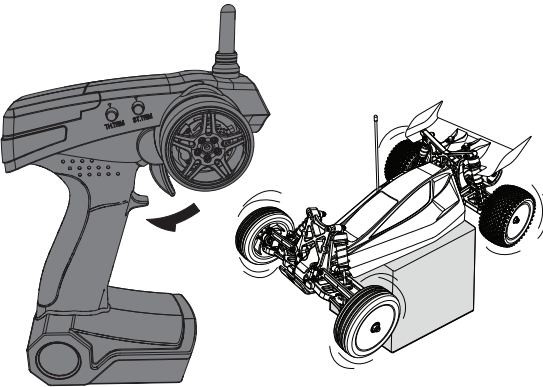

4. Start driving slowly, and, if the vehicle does not go straight, adjust the steering trim dial on the transmitter.

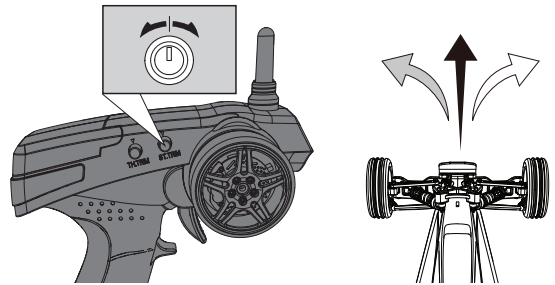

**NOTICE:** Seat the motor brushes by driving smoothly on a flat surface during use of the first battery charge. Properly seating the motor brushes will increase the life and performance of the motor.

## INSTALLING THE VEHICLE BODY

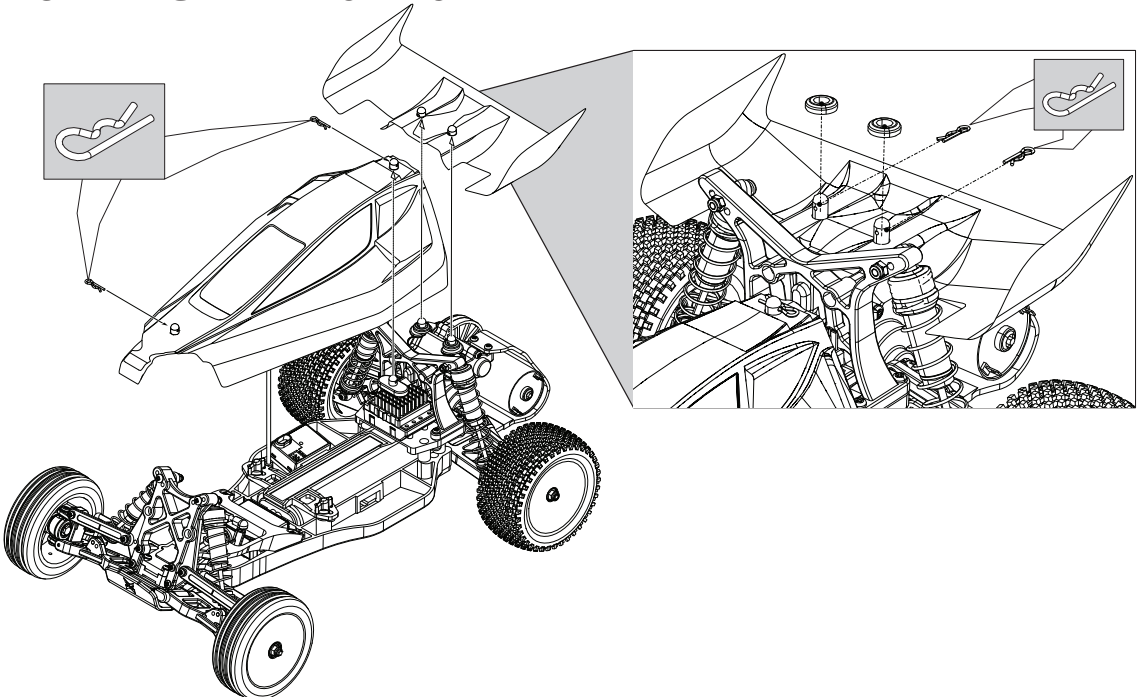

## OPERATION

- ALWAYS turn on your transmitter before you turn on the receiver in the vehicle. Always power off the receiver before turning your transmitter off.
- ALWAYS operate your vehicle in a wide open area. Operating the vehicle in a small space or indoors can cause overheating at low speeds. Operating at low speed increases heat in the electronic speed control (ESC). Overheating can damage the vehicle and failure may result.

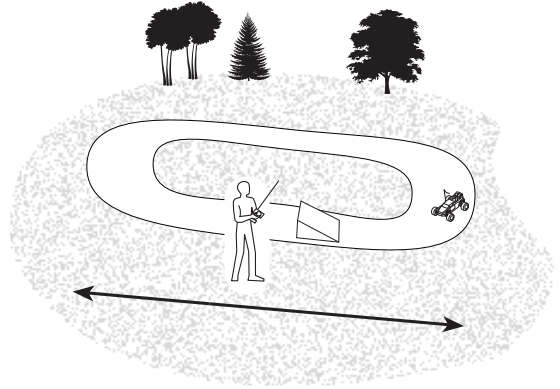
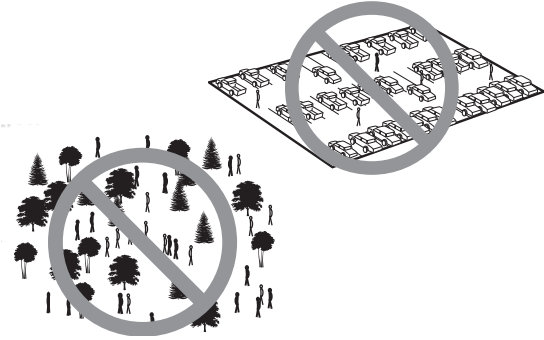

## WHEN YOU ARE FINISHED

1. Power off the Electronic Speed Control (ESC).
2. Disconnect the battery.
3. Power off the transmitter.

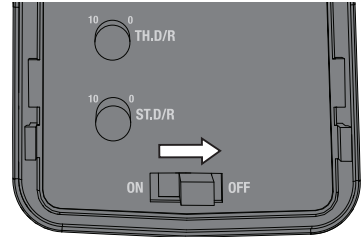
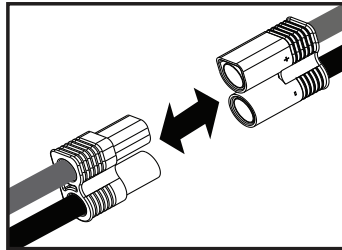
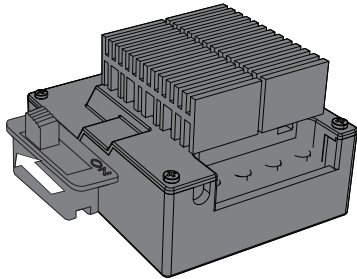

4. Remove the battery from the vehicle.
5. Recharge the battery.

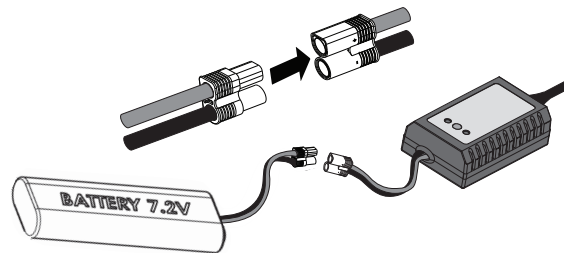
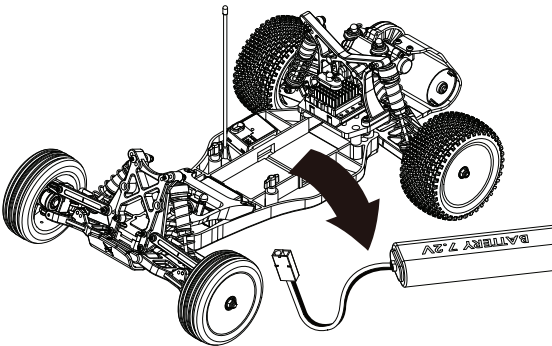

## MOTOR CARE

- Seat the motor brushes by driving smoothly on a flat surface during use of the first battery charge. **Failing to do so can greatly reduce motor performance and functional life.**
- Prolong motor life by preventing overheating conditions. Undue motor wear results from frequent turns, stops and starts, pushing objects, driving in deep sand and tall grass, and driving continuously uphill.
- Over-temperature protection is installed on the ESC to prevent circuit damage, but cannot protect the motor from driving against heavy resistance.



# MAINTENANCE

## SETTING THE GEAR MESH

The gear mesh has already been set at the factory. Setting the gear mesh is only necessary when changing motors or gears.

You must remove the vehicle's gear cover (A) to make this adjustment.

Proper gear mesh (how the gear teeth meet) is important to the performance of the vehicle. When the gear mesh is too loose, the spur gear could be damaged by the pinion gear of the motor. If the mesh is too tight, speed could be limited and the motor and ESC will overheat. Set the gear mesh by following these simple steps:

1. Loosen the 2 motor screws (B).
2. Put a small piece of paper (C) between the pinion and spur gears.
3. Push the gears together while tightening the motor screws.
4. Rotate the gears to remove the paper. The gearing should move a small amount.
5. Reinstall the gear cover.

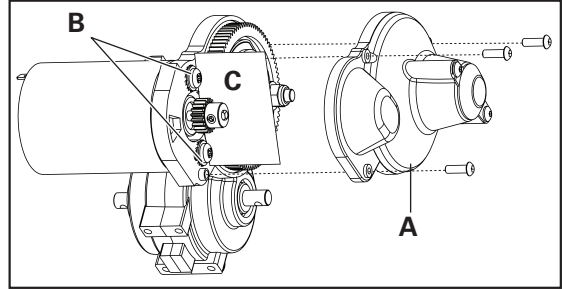

## ELECTRONIC SPEED CONTROL (ESC)

Low voltage cutoff (LVC) protects the battery from overdischarge by activating when the battery reaches 1V per cell under load. The ESC will reset after approximately 10 seconds. The vehicle can then be driven slowly back to the driver for battery recharge.

**Important:** When the motor is disconnected or damaged, the beep may not be heard.

**NOTICE:** Continually driving to LVC may damage the battery.

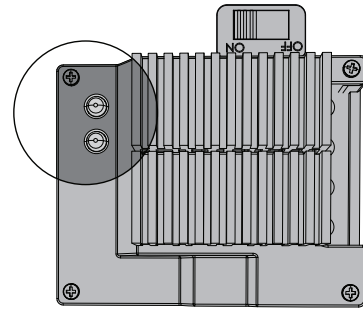

Operation	LED Color	LED Status	Sound
Ni-MH at Power ON	Flashing Green	ON	
Li-Po at Power ON	Flashing Red	ON	
NORMAL	Stop	Solid Green	ON
	Forward	All	OFF
	Forward (full speed)	Red	ON
	Reverse	All	OFF
	Reverse (full speed)	Green	ON
	Brake	All Solid	ON
Overheat	All LEDs	LEDs alternately flashing	1 beep per second
Motor Stalled	Red LED	Flashing quickly 3 times, stopping, then repeating	1 beep per second
Battery Over Voltage (over 10V)	All LEDs	Solid Red LED. Green LED flashing once per second	1 beep per second
Battery Depleted/Discharged	Red	Flashing once per second	1 beep per second

## ELECTRICAL LAYOUT

Part #	Description
A	DYN1171 Motor
B	DYN1050EC Battery 7.2V
C	DYN3900 Steering Servo
D	ECX9011 Receiver
E	DYN4925WP Electronic Speed Control (ESC)
F	Channel 1
G	Channel 2

For correct operation, Channels 1 and 2 must be used as shown in the wiring diagram. The motor can be disconnected from the ESC at the connectors in the wiring.

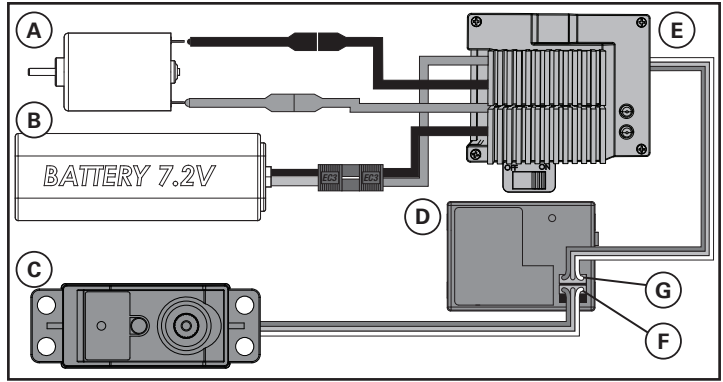

## SHOCK CLEANING

Oil-filled shocks will require regular maintenance due to the oil breaking down or getting dirty. This maintenance should be performed after about every 3 to 5 hours of use, depending on the conditions that the vehicle is used in.

- Remove the shock from the vehicle.
- Remove the cap from the shock body and dispose of fluid.
- Disassemble the shock. Clean thoroughly with DYN5505. Dry parts before assembly.
- Re-assemble the shock and refill the shock body with silicone fluid (30 weight recommended).
- Slowly move the shaft and piston up and down to remove air bubbles.
- Move the piston to the midway point of the body and install the cap.
- Wipe off any overflowing fluid.
- When properly filled, the piston should rebound about 3/8 in (9.5mm) after being pushed in fully.
- Re-install the shock on the vehicle.

### Ride Height Adjustment

Ride height is an adjustment that affects the way the vehicle jumps, turns and goes over bumps. Drop one end of the vehicle from approximately 6 inches (152 mm) in height onto a flat surface. When dropping the front of the vehicle, after the vehicle settles, make sure the front arms are equal and parallel to the flat surface. Do the same with the rear to make sure both arms are parallel with the flat surface.

Lowering the front ride height increases steering, but decreases traction. Lowering the rear ride height increases traction, but decreases steering.

### REAR SHOCK

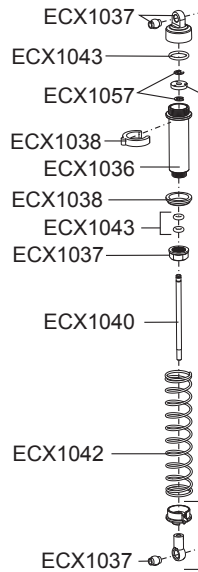



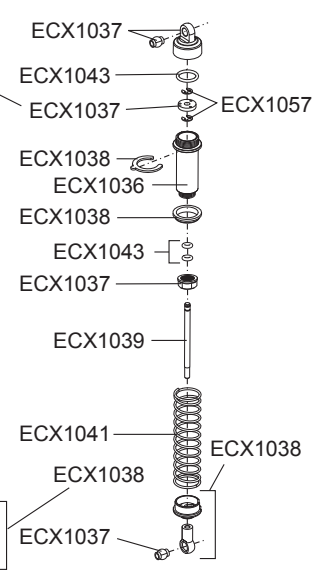











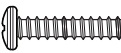

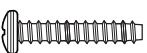





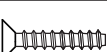

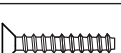

### FRONT SHOCK

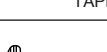
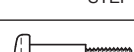

Part #	Description
ECX1036	Shock Body Set
ECX1037	Shock Caps, Pistons
ECX1038	Shock Parts Set
ECX1039	Front Shock Shaft (2)
ECX1040	Rear Shock Shaft (2)
ECX1041	Front Shock Springs (2)
ECX1042	Rear Shock Springs (2)
ECX1043	Shock O-Ring Set

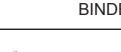
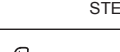
## FASTENERS

No.	Description	No.	Description	No.	Description
	TAPPING BINDER HEAD M3x10mm		BINDER HEAD M3x20mm		SETSCREW M3x3mm
	TAPPING BINDER HEAD M3x12mm		BINDER HEAD M3x25mm		SETSCREW M3x12mm
	TAPPING BINDER HEAD M3x16mm		BUTTON HEAD M3x30mm		SET SHAFT SCREW M3x13mm
	TAPPING BINDER HEAD M3x18mm		BUTTON HEAD M2x6mm		WASHER 5x7x0.5mm
	TAPPING FLAT HEAD M3x10mm		TAPPING BUTTON HEAD M3x10mm		WASHER 3x8x0.5mm
	TAPPING FLAT HEAD M3x12mm		BUTTON HEX M2.5x4mm		WASHER 2x7x0.5mm
	TAPPING FLAT HEAD M3x15mm		BUTTON HEX M2.5x8mm		FLANGED LOCK NUT M4
	TAPPING FLAT HEAD M2x16mm		STEP SCREW M3x0.5x7.4mm		LOCK NUT M3
	BINDER HEAD M3x8mm		STEP SCREW M3x0.5x13.4mm		E-CLIP E2.5
	BINDER HEAD M3x12mm		STEP SCREW M3x0.5x10.5mm		LOCK WASHER

## BINDING

### Failsafe

In the unlikely event the radio connection is lost during use, the receiver will reduce the throttle to the neutral position. The steering channel holds the last input command. If you power on the receiver before powering on the transmitter, the receiver enters failsafe mode with the throttle at the neutral position. When you power on the transmitter, normal control resumes.

Binding is the process of programming the receiver to recognize the GUID (Globally Unique Identifier) code of a single specific transmitter. The included transmitter and receiver are bound at the factory. If you need to rebind, follow the instructions below.

1. Power off the transmitter and ESC.
2. Connect a fully charged battery pack to the ESC.
3. Power on the ESC.
4. Remove the front cover. Press the bind button (A) on the receiver. The RED LED on the receiver flashes rapidly.
5. Power on the transmitter.
6. The RED LED on the receiver turns solid when the system is bound. Replace the front cover.

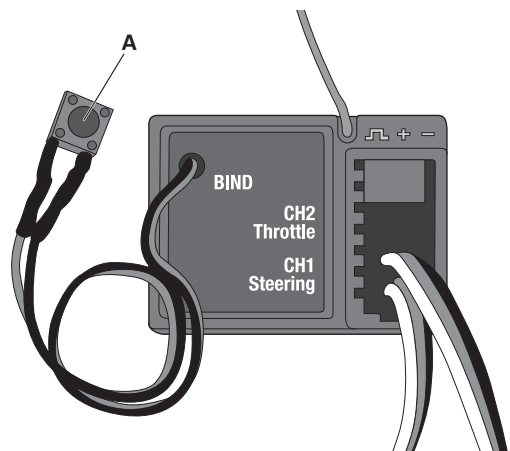

You must rebind when you want to use a different transmitter.

## TROUBLESHOOTING GUIDE

Problem	Possible Cause	Solution
Short Run Time	<ul style="list-style-type: none"> <li>Battery damaged/not charged</li> <li>Motor dirty or brushes worn</li> </ul>	<ul style="list-style-type: none"> <li>Check/change battery</li> <li>Check/clean/replace</li> </ul>
Sluggish Action	<ul style="list-style-type: none"> <li>Motor dirty or brushes worn</li> <li>Bind in drivetrain</li> <li>Vehicle battery is not charged</li> </ul>	<ul style="list-style-type: none"> <li>Check/clean/replace</li> <li>Clean/adjust</li> <li>Replace/recharge</li> </ul>
Controls Reversed	<ul style="list-style-type: none"> <li>ST. REV or TH. REV</li> </ul>	<ul style="list-style-type: none"> <li>Change switch position</li> </ul>
Motor/ESC overheat	<ul style="list-style-type: none"> <li>Over-geared</li> </ul>	<ul style="list-style-type: none"> <li>Install smaller pinion</li> </ul>
Doesn't Operate	<ul style="list-style-type: none"> <li>Transmitter batteries low</li> <li>Transmitter powered off</li> <li>ESC powered off</li> <li>Vehicle battery is not charged</li> </ul>	<ul style="list-style-type: none"> <li>Replace/recharge</li> <li>Power On</li> <li>Power On</li> <li>Replace/recharge</li> </ul>
Poor Range	<ul style="list-style-type: none"> <li>Transmitter batteries low</li> <li>Transmitter antenna is damaged or loose</li> <li>Receiver antenna damaged</li> </ul>	<ul style="list-style-type: none"> <li>Replace/recharge</li> <li>Check/tighten</li> <li>Check/repair/replace</li> </ul>
The system will not connect	<ul style="list-style-type: none"> <li>Transmitter and receiver too near each other</li> <li>Transmitter and receiver too near large metal objects (vehicles, etc.)</li> <li>Transmitter accidentally put in bind mode; receiver is no longer bound</li> </ul>	<ul style="list-style-type: none"> <li>Move transmitter 8–12 feet (2.4–3.6m) from receiver</li> <li>Move away from large metal objects (vehicles, etc.)</li> <li>Rebind transmitter and receiver</li> </ul>
The receiver goes into failsafe mode a short distance away from the transmitter	<ul style="list-style-type: none"> <li>Check the receiver antenna to ensure it is not cut or damaged</li> </ul>	<ul style="list-style-type: none"> <li>Contact Horizon Product Support</li> <li>Make sure receiver antenna is in an antenna tube and is above vehicle</li> </ul>
The receiver quits responding during operation	<ul style="list-style-type: none"> <li>Low battery voltage</li> <li>Loose or damaged wires or connectors between battery and receiver</li> </ul>	<ul style="list-style-type: none"> <li>Completely recharge battery</li> <li>Do a check of the wires and connection between battery and receiver. Repair or replace wires and/or connectors</li> </ul>

## LIMITED WARRANTY

**What this Warranty Covers** - Horizon Hobby, Inc. ("Horizon") warrants to the original purchaser that the product purchased (the "Product") will be free from defects in materials and workmanship at the date of purchase.

**What is Not Covered** - This warranty is not transferable and does not cover (i) cosmetic damage, (ii) damage due to acts of God, accident, misuse, abuse, negligence, commercial use, or due to improper use, installation, operation or maintenance, (iii) modification of or to any part of the Product, (iv) attempted service by anyone other than a Horizon Hobby authorized service center, (v) Product not purchased from an authorized Horizon dealer, or (vi) Product not compliant with applicable technical regulations. OTHER THAN THE EXPRESS WARRANTY ABOVE, HORIZON MAKES NO OTHER WARRANTY OR REPRESENTATION, AND HEREBY DISCLAIMS ANY AND ALL IMPLIED WARRANTIES, INCLUDING, WITHOUT LIMITATION, THE IMPLIED WARRANTIES OF NON-INFRINGEMENT, MERCHANTABILITY AND FITNESS FOR A PARTICULAR PURPOSE. THE PURCHASER ACKNOWLEDGES THAT THEY ALONE HAVE DETERMINED THAT THE PRODUCT WILL SUITABLY MEET THE REQUIREMENTS OF THE PURCHASER'S INTENDED USE.

**Purchaser's Remedy** - Horizon's sole obligation and purchaser's sole and exclusive remedy shall be that Horizon will, at its option, either (i) service, or (ii) replace, any Product determined by Horizon to be defective. Horizon reserves the right to inspect any and all Product(s) involved in a warranty claim. Service or replacement decisions are at the sole discretion of Horizon. Proof of purchase is required for all war-

ranty claims. SERVICE OR REPLACEMENT AS PROVIDED UNDER THIS WARRANTY IS THE PURCHASER'S SOLE AND EXCLUSIVE REMEDY. **Limitation of Liability** - HORIZON SHALL NOT BE LIABLE FOR SPECIAL, INDIRECT, INCIDENTAL OR CONSEQUENTIAL DAMAGES, LOSS OF PROFITS OR PRODUCTION OR COMMERCIAL LOSS IN ANY WAY, REGARDLESS OF WHETHER SUCH CLAIM IS BASED IN CONTRACT, WARRANTY, TORT, NEGLIGENCE, STRICT LIABILITY OR ANY OTHER THEORY OF LIABILITY, EVEN IF HORIZON HAS BEEN ADVISED OF THE POSSIBILITY OF SUCH DAMAGES. Further, in no event shall the liability of Horizon exceed the individual price of the Product on which liability is asserted. As Horizon has no control over use, setup, final assembly, modification or misuse, no liability shall be assumed nor accepted for any resulting damage or injury. By the act of use, setup or assembly, the user accepts all resulting liability. If you as the purchaser or user are not prepared to accept the liability associated with the use of the Product, purchaser is advised to return the Product immediately in new and unused condition to the place of purchase.

**Law** - These terms are governed by Illinois law (without regard to conflict of law principals). This warranty gives you specific legal rights, and you may also have other rights which vary from state to state. Horizon reserves the right to change or modify this warranty at any time without notice.

### WARRANTY SERVICES

**Questions, Assistance, and Repairs** - Your local hobby store and/or place of purchase cannot provide warranty support or service. Once assembly, setup or use of the Product has been started, you must contact

your local distributor or Horizon directly. This will enable Horizon to better answer your questions and service you in the event that you may need any assistance. For questions or assistance, please visit our website at [www.horizonhobby.com](http://www.horizonhobby.com), submit a Product Support Inquiry, or call 877.504.0233 toll free to speak to a Product Support representative.

**Inspection or Services** - If this Product needs to be inspected or serviced and is compliant in the country you live and use the Product in, please use the Horizon Online Service Request submission process found on our website or call Horizon to obtain a Return Merchandise Authorization (RMA) number. Pack the Product securely using a shipping carton. Please note that original boxes may be included, but are not designed to withstand the rigors of shipping without additional protection. Ship via a carrier that provides tracking and insurance for lost or damaged parcels, as Horizon is not responsible for merchandise until it arrives and is accepted at our facility. An Online Service Request is available at [http://www.horizonhobby.com/content/\\_service-center\\_render-service-center](http://www.horizonhobby.com/content/_service-center_render-service-center). If you do not have internet access, please contact Horizon Product Support to obtain a RMA number along with instructions for submitting your product for service. When calling Horizon, you will be asked to provide your complete name, street address, email address and phone number where you can be reached during business hours. When sending product into Horizon, please include your RMA number, a list of the included items, and a brief summary of the problem. A copy of your original sales receipt must be included for warranty consideration. Be sure your name, address, and RMA number are clearly written on the outside of the shipping carton.

## Contact Information

Country of Purchase	Horizon Hobby	Address	Phone Number / Email Address
United States of America	Horizon Service Center (Electronics and engines)	4105 Fieldstone Rd Champaign, Illinois 61822 USA	877-504-0233 productsupport@horizonhobby.com
	Horizon Product Support		
United Kingdom	Horizon Hobby Limited	Units 1-4 Ployters Rd, Staple Tye, Harlow, Essex, CM18 7NS, United Kingdom	+44 (0) 1279 641 097 sales@horizonhobby.co.uk
Germany	Horizon Technischer Service	Christian-Junge-Straße 1 25337 Elmshorn, Germany	+49 (0) 4121 2655 100 service@horizonhobby.de
France	Horizon Hobby SAS	14 Rue Gustave Eiffel, Zone d'Activité du Réveil Matin, 91230 Montgeron	+33 (0) 1 60 47 44 70 infofrance@horizonhobby.com
China	Horizon Hobby - China	Room 506, No. 97 Changshou Rd. Shanghai, China 200060	+86 (021) 5180 9868 info@horizonhobby.com.cn

**NOTICE: Do not ship LiPo batteries to Horizon. If you have any issue with a LiPo battery, please contact the appropriate Horizon Product Support office.**

**Warranty Requirements - For Warranty consideration, you must include your original sales receipt verifying the proof-of-purchase date.** Provided warranty conditions have been met, your Product will be serviced or replaced free of charge. Service or replacement decisions are at the sole discretion of Horizon.

**Non-Warranty Repairs - Should your service not be covered by warranty, service will be completed and payment will be required without notification or estimate of the expense unless the expense exceeds 50% of the retail purchase cost.** By submitting the item for service you are agreeing to payment of the service without notification. Service estimates are available upon request. You must include this request with your item submitted for service. Non-warranty service estimates will be billed a minimum of ½ hour of labor. In addition you will be billed for return freight. Horizon accepts money orders and cashier's checks, as well as Visa, MasterCard, American Express, and Discover cards. By submitting any item to Horizon for service, you are agreeing to Horizon's Terms and Conditions found on our website [http://www.horizonhobby.com/content/\\_service-center\\_render-service-center](http://www.horizonhobby.com/content/_service-center_render-service-center).

**NOTICE: Horizon service is limited to Product compliant in the country of use and ownership. If non-compliant product is received by Horizon for service, it will be returned unserviced at the sole expense of the purchaser.**

## FCC INFORMATION

This device complies with part 15 of the FCC rules. Operation is subject to the following two conditions: (1) This device may not cause harmful interference, and (2) this device must accept any interference received, including interference that may cause undesired operation.



**CAUTION:** Changes or modifications not expressly approved by the party responsible for compliance could void the user's authority to operate the equipment.

This product contains a radio transmitter with wireless technology which has been tested and found to be compliant with the applicable regulations governing a radio transmitter in the 2.400GHz to 2.4835GHz frequency range.

# COMPLIANCE INFORMATION FOR THE EUROPEAN UNION

## CE Declaration of Conformity

(in accordance with ISO/IEC 17050-1)

No. HH2012082701

Product(s): ECX 1/10th Scale Boost V2.0

Item Number(s): ECX3000SEU/ECX3100SEU

Equipment class: 1

The object of declaration described above is in conformity with the requirements of the specifications listed below, following the provisions of the European R&TTE directive 1999/5/EC, EMC Directive 2004/108/EC and LVD Directive 2006/95/EC:

**EN 300-328 V1.7.1: 2006**

**EN 301 489-1 V1.7.1: 2006**

**EN 301 489-17 V1.3.2: 2008**

**EN 60950-1:2006+A12: 2011**

**EN55022: 2010**

**EN55024: 2010**

**EN61000-3-2:2006+A1:2009+A2:2009**

**EN61000-3-3:2008**

Signed for and on behalf of:

Horizon Hobby, Inc.

Champaign, IL USA

August 27, 2012

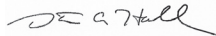

Steven A. Hall

Executive Vice President and Chief Operating Officer

International Operations and Risk Management

Horizon Hobby, Inc.



## Instructions for disposal of WEEE by users in the European Union

This product must not be disposed of with other waste. Instead, it is the user's responsibility to dispose of their waste equipment by handing it over to a designated collection point for the recycling of waste electrical and electronic equipment. The separate collection and recycling of your waste equipment at the time of disposal will help to conserve natural resources and ensure that it is recycled in a manner that protects human health and the environment. For more information about where you can drop off your waste equipment for recycling, please contact your local city office, your household waste disposal service or where you purchased the product.

# PARTS DIAGRAM | EXPLOSIONSZEICHNUNG | VUE ÉCLATÉE DES PIÈCES | ESPLOSO DEL MODELLO CON REFERENZA PEZZI

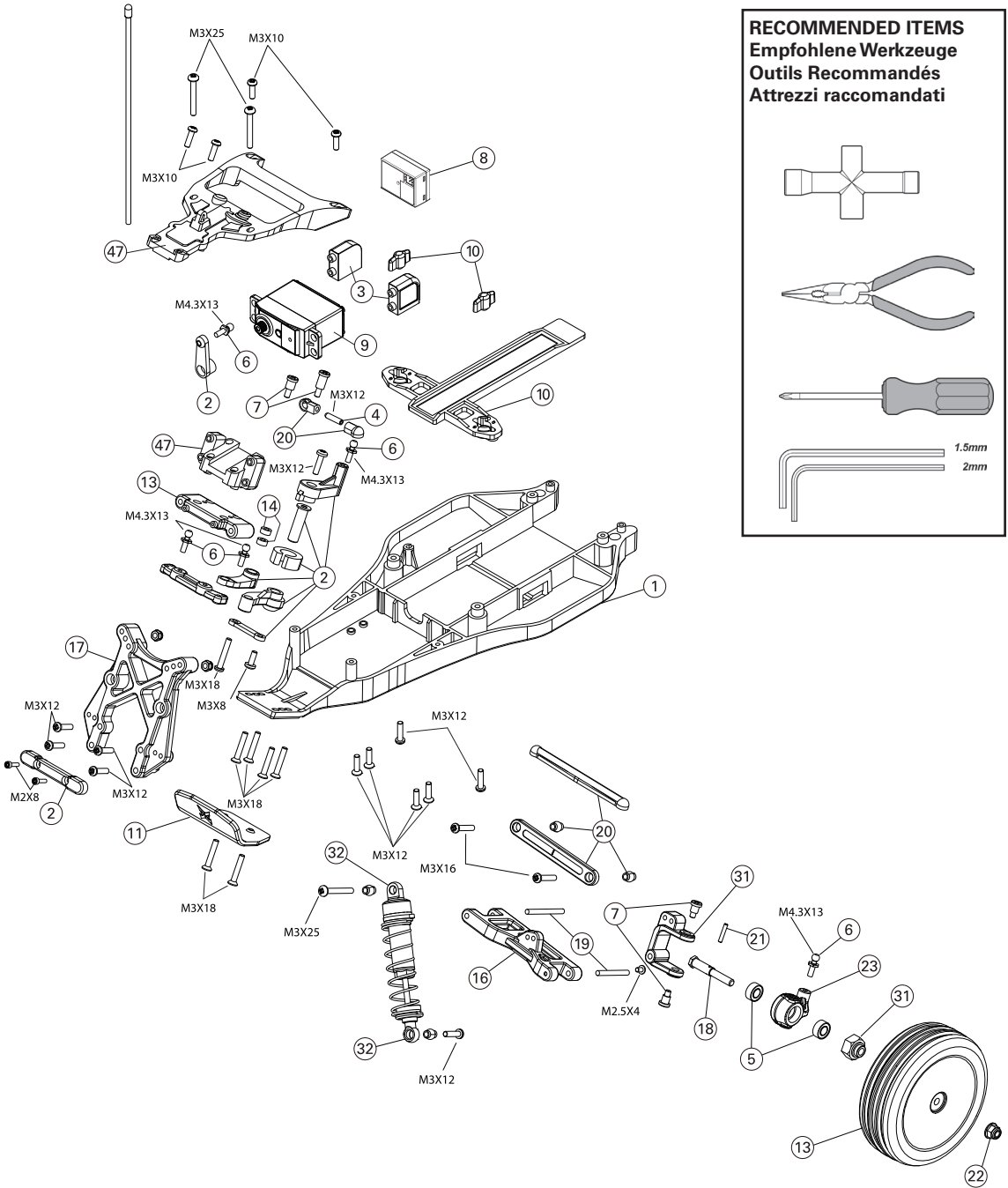

# PARTS DIAGRAM | EXPLOSIONSZEICHNUNG | VUE ÉCLATÉE DES PIÈCES | ESPLOSO DEL MODELLO CON REFERENZA PEZZI

The slipper clutch can be adjusted using this locknut (ECX1060). Fully tighten the locknut. Then loosen the nut two full turns.

Die Rutschkupplung kann durch diese Stopmutter eingestellt werden (ECX1060). Ziehen Sie die Mutter an und drehen Sie dann volle zwei Umdrehungen zurück.

Il est possible d'ajuster l'embrayage "patinant" par action sur cet écrou de blocage (ECX1060). Veuillez à serrer l'écrou de blocage à fond. Ensuite, dévissez l'écrou de deux tours complets.

La frizione può essere regolata con questo dado autobloccante (ECX1060). Prima avvitate complet-amente il dado, poi svitatelo 2 giri.

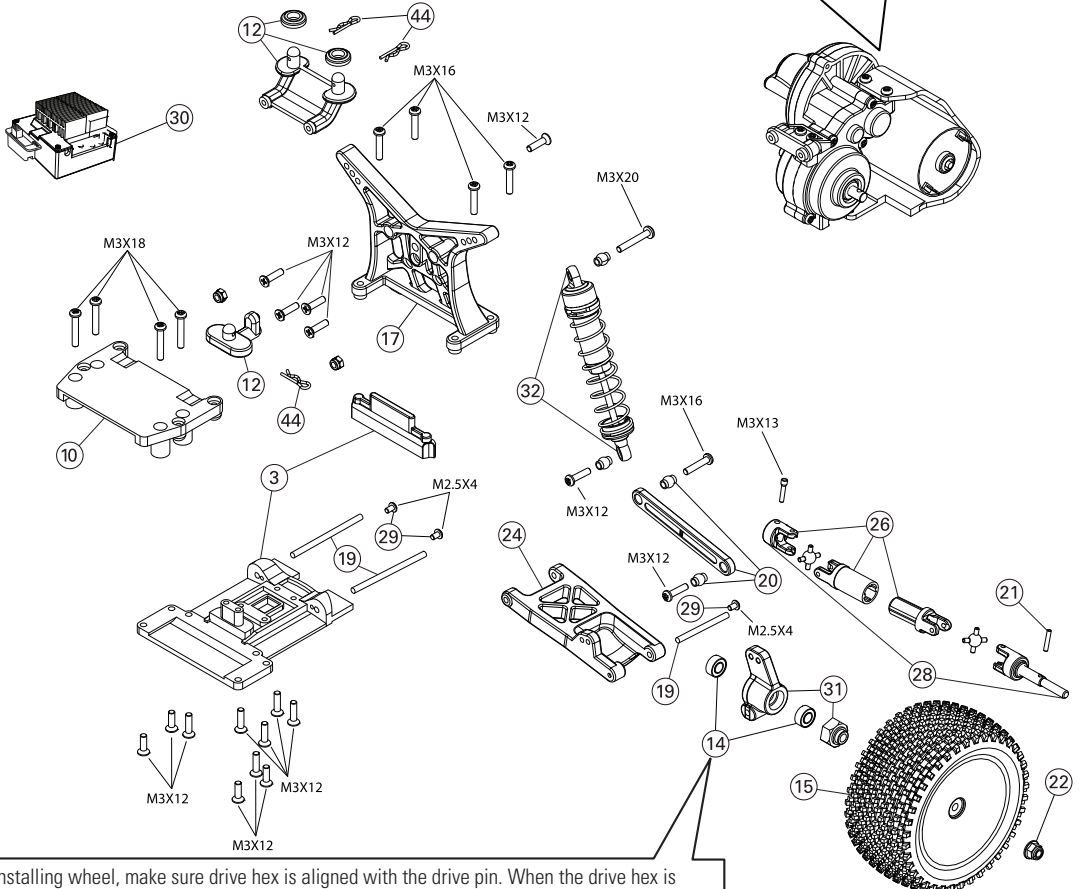
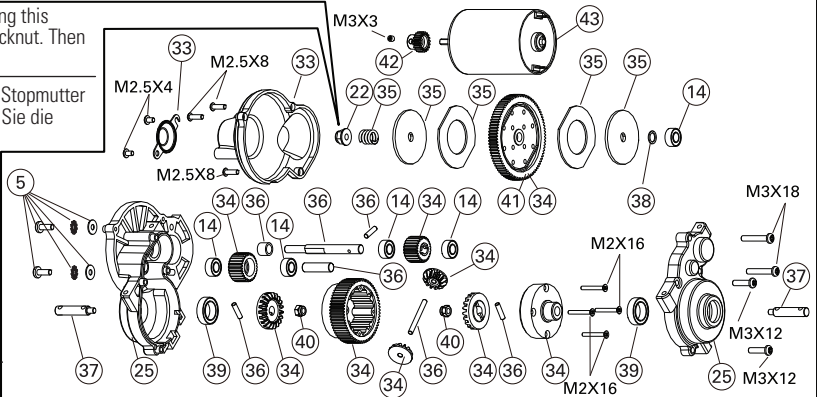

When installing wheel, make sure drive hex is aligned with the drive pin. When the drive hex is removed, the drive pin can fall out of the axle.

Bitte achten Sie bei der Radmontage darauf, dass die Radachse im Radmitnehmer sitzt und dass der der Querstift nicht heraus fällt.

Lors de l'installation de la roue, assurez-vous que l'écrou hexagonal est aligné avec la broche de l'axe d'entraînement. En cas de démontage de l'écrou hexagonal, la broche de l'axe d'entraînement peut sortir de l'axe et tomber.

Quando montate le ruote, accertatevi che il trascinatore esagonale sia allineato con la spina del mozzo ruota. Quando togliete il trascinatore esagonale la spina può sfilarsi dal mozzo.



Part #   Numer Numéro   Codice	Description	Beschreibung	Description	Descrizione	
1	ECX3007	Main Chassis	Chassis	Châssis principal	Telaio principale
2	ECX1028	Servo Saver Set	Servo Saver Set	Jeu de sauvegarde de servo	Set salvaservo
3	ECX1092	Rear Suspension Mount Set	Querlenkerhalter hinten	Jeu de renfort de suspension arrière	Supporti braccetti sosp. posteriori
4	ECX1050	Setscrew M3x12 (4)	Schrauben Set M3x12 (4)	Jeu de vis M3x12 (4)	Grani M3x12 (4)
5	ECX1052	Motor Screw/Washer Set	Motor Screw/Washer Set	Vis Moteur/Set Rondelles	Viti per il motore/ set di rondelle
6	ECX1058	Ball Stud (6)	Kugelkopf (6)	Rondelle (6)	Sfere Uniball (6)
7	ECX1065	Shoulder Screw Set (8)	Passschrauben Set (8)	Jeu de vis d'épaulement (8)	Set viti a doppio stadio (8)
8	ECX9011	Receiver	Empfänger	Récepteur	Ricevente
9	DYN3900	Servo	Servo	Servo	Servo
10	ECX1088	Battery Hold Down	Akkuhalter	Fixation pour batterie	Piastra fermabatteria
11	ECX1091	Front/Rear Bumper Set	Stoßstange vorne hinten	Jeu de pare-chocs avant/arrière	Set paraurti ant/post
12	ECX3015	Body Mount Set	Body Mount Set	Set Montage Carrosserie	Set di montaggio per la carrozzeria
13	ECX3005	Front Mounted Wheel/Tire (2)	Mounted Wheel/Tire (2)	Roue Montée/Pneu (2)	Ruote e gomme montate (2)
14	ECX1015	Wheel Bearing Set	Radlagersatz Set	Jeu de roulement de roue	Set cuscinetti ruote
15	ECX3006	Rear Mounted Wheel/Tire (2)	Rear Mounted Wheel/Tire (2)	Rear Mounted Wheel/Tire (2)	Rear Mounted Wheel/Tire (2)
16	ECX3008	Front Suspension Arm Set	Querlenker Set vorne	Jeu de bras de suspension avant	Braccetti delle sospensioni anteriori
17	ECX3010	Shock Tower Set	Dämpferbrücke	Jeu de support d'amortisseur	Supporto ammortizzatori posteriori
18	ECX1035	Front Axle (2)	Radachse vorne (2)	Axe avant (2)	Mozzi ruota anteriori (2)
19	ECX1044	Hinge Pin Set	Querlenkerbolzen Set	Jeu de broche d'axe	Set perni sospensioni
20	ECX3012	Camber, Toe Link Set	Spur- Sturzstangenset	Jeu de biellette de cambrure, de pincement	Set tiranteria Camber e convergenza
21	ECX1049	Wheel Pins (4)	Radmitnehmerstifte (4)	Broches de roue (4)	Spine trascinatori ruote (4)
22	ECX1060	M4 Locknut (4)	M4 Stopmutter (4)	Ecrou de blocage M4 (4)	Dadi autobloccanti M4 (4)
23	ECX1089	Steering Block Set	Lenkhebel Set	Jeu de bloc de direction	Fuselli sterzo
24	ECX3009	Rear Suspension Arm Set	Querlenker Set hinten	Jeu de bras de suspension arrière	Braccetti delle sospensioni posteriori
25	ECX1021	Transmission Case Set	Getriebegehäuse	Ensemble carter de transmission	Set scatola trasmissione
26	ECX230003	Driveshaft Set	Antriebswellen Set	Ensemble arbre de transmission	Set semiassi
28	ECX230003	Rear Axle (2)	Wellenmitnehmer hinten (2)	Axe arrière (2)	Mozzi ruota anteriori (2)
29	ECX1045	Hinge Pin Screws (8)	Querlenkerbolzen Schrauben (8)	Vis de broche d'axe (8)	Viti per perni sospensioni (8)
30	DYN4925WP	ESC	Regler / ESC	CEV	Variatore elettronico (ESC)
31	ECX1090	Hub Carrier Set	Hinterer Rad Träger Set	Jeu de porte-moyeu arrière	Portamozzi posteriori
32	ECX1037	Shock Caps, Pistons	Stoßdämpferkappen Kolben	Obturateurs d'amortisseur, pistons	Set tappi e pistoni ammortizzatori
33	ECX1027	Gear Cover	Gear Cover	Carter de Réducteur	Copertura per ingranaggi
34	ECX1022	Transmission Gear Set	Getriebe	Ensemble couronne de transmission	et ingranaggi trasmissione
35	ECX1024	Slipper Clutch Plates, Pads, Spring	Rutschkupplung Teilesatz	Plateaux d'embrayage patinant, plaquettes, ressort	Piattelli frizione, disco, molla

Part #   Nummer Numéro   Codice	Description	Beschreibung	Description	Descrizione
36 ECX1025	Transmission Idler Shaft, Drive Pins	Hauptgetriebewelle Set	Arbre secondaire de transmission, axes d'entraînement	Alberino intermedio con spina
37 ECX1026	Transmission Drive Shaft (2)	Getriebeausgangswelle (2)	Axe d'arbre de transmission (2)	Mozzi Differenziale (2)
38 ECX1052	Washer Set	Unterlegscheiben Set	Jeu de rondelles	Set rondelle
39 ECX1055	Bearings 10x15x4 (2)	Lager 10x15x4 (2)	Roulements 10x15x4 (2)	Cuscinetti 10x15x4 (2)
40 ECX1059	M3 Locknut (4)	M3 Stopmutter (4)	Ecrou de blocage M3 (4)	Dadi autobloccanti M3 (4)
41 ECX1076	Spur Gear	Hauptzahnrad	Couronne	Corona
42 ECX3018	20-Tooth Pinion Gear	20-Tooth Pinion Gear	Pignon 10 dents	Pignone a 20 denti
43 DYN1171	Dynamite 20-Turn Brushed Motor	Dynamite 20-Turn Brushed Motor	Dynamite 20-Turn Brushed Motor	Dynamite 20-Turn Brushed Motor
44 ECX1048	Body Clip	Body Clip	Clips Carrosserie	Clippe per carrozzeria
45 ECX1023	Top Shaft/Spacer	Top Shaft/Spacer	Set de Goupilles	Set di spessori
46 ECX1033	Setscrew M3x10	Sicherungsschrauben (4)	Vis (4)	Viti (4)
47 ECX1029	Top Plate	Chassioberteil	Plaque frontale	Piastra superiore
ECX9010	Transmitter	Sender	Émetteur	Trasmettitore
DYN1050EC	Ni-MH battery	Ni-MH akku	Batterie Ni-MH	Batteria Ni-MH
DYN4113	2A Peak Charger	2A Peak Ni-MH Ladegerät	2A Chargeur à détection de pics	2A Caricabatterie a rilevamento di picchi



ECX3000S, ECX3000SA, ECX3000SEU | ECX3100S, ECX3100SA, ECX3100SEU

[www.ecxrc.com](http://www.ecxrc.com)

33775 Created 8/2012

© 2012 Horizon Hobby, Inc.

Horizon Hobby, ECX, Boost, Dynamite and Speedpack are trademarks or registered trademarks of Horizon Hobby, Inc.

WD-40 is a registered trademark of WD-40 Manufacturing Company.