

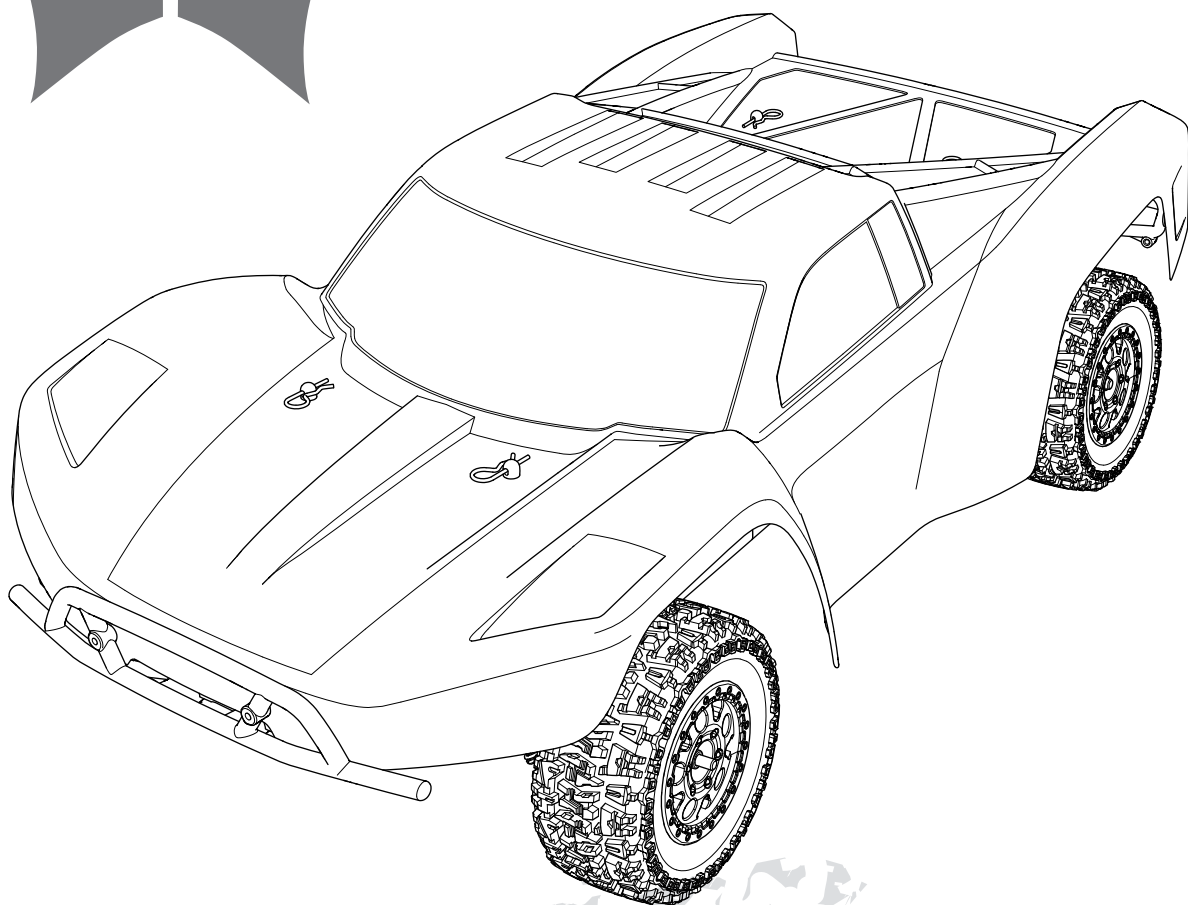

ECX[®]



TORMENT[™] 1/10 4WD ELECTRIC SHORT COURSE TRUCK

ECX03013 | ECX03013AU | ECX03013I

**INSTRUCTION MANUAL
BEDIENUNGSANLEITUNG
MANUEL D'UTILISATION
MANUALE DI ISTRUZIONI**

Congratulations on your purchase of the ECX[®] Torment[™] Short Course Truck. This 1/10-scale model introduces you to the sport of RC driving.

Herzlichen Glückwunsch zum Kauf des ECX Torment Short Course Truck. Dieses 1/10 Scale Model öffnet Ihnen die Welt des RC Car Sports.

Nous vous félicitons pour l'achat du ECX Torment Short Course Truck. Ce modèle 1/10 vous initie à la conduite RC.

Congratulazioni per l'acquisto di questo Torment Short Course Truck ECX. Questa vettura in scala 1/10 vi introdurrà nel mondo dei modelli RC.

NOTICE

All instructions, warranties and other collateral documents are subject to change at the sole discretion of Horizon Hobby, LLC. For up-to-date product literature, visit <http://www.horizonhobby.com> and click on the support tab for this product.

Meaning of Special Language:

The following terms are used throughout the product literature to indicate various levels of potential harm when operating this product:

NOTICE: Procedures, which if not properly followed, create a possibility of physical property damage AND little or no possibility of injury.

CAUTION: Procedures, which if not properly followed, create the probability of physical property damage AND a possibility of serious injury.

WARNING: Procedures, which if not properly followed, create the probability of property damage, collateral damage, and serious injury OR create a high probability of superficial injury.



WARNING: Read the ENTIRE instruction manual to become familiar with the features of the product before operating. Failure to operate the product correctly can result in damage to the product, personal property and cause serious injury.

This is a sophisticated hobby product and NOT a toy. It must be operated with caution and common sense and requires some basic mechanical ability. Failure to operate this Product in a safe and responsible manner could result in injury or damage to the product or other property. This product is not intended for use by children without direct adult supervision. Do not use with incompatible components or alter this product in any way outside of the instructions provided by Horizon Hobby, Inc. This manual contains instructions for safety, operation and maintenance. It is essential to read and follow all the instructions and warnings in the manual, prior to assembly, setup or use, in order to operate correctly and avoid damage or serious injury.

Age Recommendation: Not for children under 14 years. This is not a toy.

Safety Precautions and Warnings

As the user of this product, you are solely responsible for operating in a manner that does not endanger yourself and others or result in damage to the product or property of others.

This model is controlled by a radio signal subject to interference from many sources outside your control. This interference can cause momentary loss of control, so it is advisable to always keep a safe distance in all directions around your model as this margin will help avoid collisions or injury.

- Never operate your model with low transmitter batteries.
- Always operate your model in open spaces away from full-size vehicles, traffic and people.
- Never operate the model in the street or in populated areas for any reason.
- Carefully follow the directions and warnings for this and any optional support equipment (chargers, rechargeable battery packs, etc.) you use.
- Keep all chemicals, small parts and anything electrical out of the reach of children.
- Never lick or place any portion of the model in your mouth as it could cause serious injury or even death.
- Exercise caution when using tools and sharp instruments.
- Take care during maintenance as some parts may have sharp edges.
- Immediately after using your model, do NOT touch equipment such as the motor, electronic speed control and battery, because they generate high temperatures. You may burn yourself seriously touching them.
- Do not put fingers or any objects inside rotating and moving parts, as this may cause damage or serious injury.
- Always turn on your transmitter before you turn on the receiver in the car. Always turn off the receiver before turning your transmitter off.
- Keep the wheels of the model off the ground when checking the operation of the radio equipment.

TABLE OF CONTENTS

Safety Precautions and Warnings	2	Operation	8
Water-Resistant Vehicle with Waterproof Electronics	3	When you are Finished	8
Specifications	3	Motor Care	8
Components	4	Maintenance	9
Vehicle Preparations	4	Electronic Speed Control (ESC).....	9
Charging the Vehicle Battery	4	Electrical Layout.....	9
Initial Charge.....	4	Shock Cleaning.....	10
Charging Warnings	4	Ride Height Adjustment.....	10
Installing Transmitter Batteries	5	Fasteners.....	10
Transmitter Battery Safety Precautions.....	5	Binding	11
Removing the Vehicle Body	5	Troubleshooting Guide	11
Installing the Battery in the Vehicle	5	Limited Warranty	12
Transmitter controls	6	Contact Information	12
Changing the Travel Adjust Settings	6	FCC Information	13
Getting Started.....	7	IC Information	13
Installing the Vehicle Body	7	Compliance Information for the European Union	14
		Parts Diagrams	54
		Parts Lists.....	56

WATER-RESISTANT VEHICLE WITH WATERPROOF ELECTRONICS

Your new Horizon Hobby vehicle has been designed and built with a combination of waterproof and water-resistant components to allow you to operate the product in many “wet conditions”, including puddles, creeks, wet grass, snow and even rain.

While the entire vehicle is highly water-resistant, it is not completely waterproof and your vehicle should NOT be treated like a submarine. The various electronic components used in the vehicle, such as the Electronic Speed Control (ESC), servo(s) and receiver are waterproof, however, most of the mechanical components are water-resistant and should not be submerged.

Metal parts, including the bearings, hinge pins, screws and nuts, as well as the contacts in the electrical cables, will be susceptible to corrosion if additional maintenance is not performed after running in wet conditions. To maximize the long-term performance of your vehicle and to keep the warranty intact, the procedures described in the “Wet Conditions Maintenance” section below must be performed regularly if you choose to run in wet conditions. If you are not willing to perform the additional care and maintenance required, then you should not operate the vehicle in those conditions.



CAUTION: Failure to exercise caution while using this product and complying with the following precautions could result in product malfunction and/or void the warranty.

General Precautions

- Read through the wet conditions maintenance procedures and make sure that you have all the tools you will need to properly maintain your vehicle.
- Not all batteries can be used in wet conditions. Consult the battery manufacturer before use. Caution should be taken when using Li-Po batteries in wet conditions.
- Most transmitters are not water-resistant. Consult your transmitter’s manual or the manufacturer before operation.
- Never operate your transmitter or vehicle where lightning may be present.
- Do not operate your vehicle where it could come in contact with salt water (ocean water or water on salt-covered roads), contaminated or polluted water. Salt water is very conductive and highly corrosive, so use caution.
- Even minimal water contact can reduce the life of your motor if it has not been certified as water-resistant or waterproof. If the motor becomes excessively wet, apply very light throttle until the water is mostly removed from the motor. Running a wet motor at high speeds may rapidly damage the motor.

- Driving in wet conditions can reduce the life of the motor. The additional resistance of operating in water causes excess strain. Alter the gear ratio by using a smaller pinion or larger spur gear. This will increase torque (and motor life) when running in mud, deeper puddles, or any wet conditions that will increase the load on the motor for an extended period of time.

Wet Conditions Maintenance

- Drain any water that has collected in the tires by spinning them at high speed. With the body removed, place the vehicle upside down and pull full throttle for a few short bursts until the water has been removed.



CAUTION: Always keep hands, fingers, tools and any loose or hanging objects away from rotating parts when performing the above drying technique.

- Remove the battery pack(s) and dry the contacts. If you have an air compressor or a can of compressed air, blow out any water that may be inside the recessed connector housing.
- Remove the tires/wheels from the vehicle and gently rinse the mud and dirt off with a garden hose. Avoid rinsing the bearings and transmission.

NOTICE: Never use a pressure washer to clean your vehicle.

- Use an air compressor or a can of compressed air to dry the vehicle and help remove any water that may have gotten into small crevices or corners.
- Spray the bearings, drive train, fasteners and other metal parts with a water-displacing light oil or lubricant. Do not spray the motor.
- Let the vehicle air dry before you store it. Water (and oil) may continue to drip for a few hours.
- Increase the frequency of disassembly, inspection and lubrication of the following:
 - Front and rear axle hub assembly bearings.
 - All transmission cases, gears and differentials.
 - Motor—clean with an aerosol motor cleaner and re-oil the bushings with lightweight motor oil.

SPECIFICATIONS

Transmitter

Frequency	2.4GHz
Modulation	DSM, DSM2, DSMR, Marine
Battery	AA x 4

Servo

Power Supply	4.8V-6V (shared with receiver)
Output Torque	41.66 oz (3 kg-cm)
Operating Speed	0.23sec/60 degrees of travel
Size	55.6 x 18 x 30mm

Electronic Speed Control (ESC)

Input Voltage	6.0–8.4 V
Electric Capacity (FET)	Forward 40A/180A
Electric Capacity (FET)	Reverse 20A/90A
PWM Frequency	1kHz
BEC Voltage	5V/2A
Size	36 x 31.7 x 18mm
Weight	65 g

COMPONENTS

1. ECX® Torment™ 1/10-scale 4WD Short Course Truck
2. Spektrum™ DX2E Transmitter
3. AA (4) Batteries
4. DYN4113 2A Peak Battery Charger
5. Dynamite® Speedpack™ 8.4V Ni-MH battery (DYN1062EC)

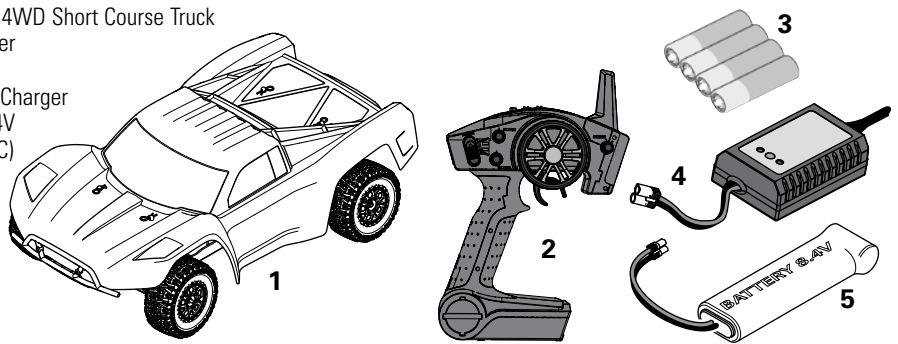

VEHICLE PREPARATIONS

CHARGING THE VEHICLE BATTERY

1. Connect the AC power cord to the power slot on the charger, then connect the other end of the power cord to an AC power source.
2. The Power LED and Charging LED will turn GREEN when the charger is connected to the AC power source.
3. Connect the battery pack connector to the charge connector.
4. Press the On/Off button to charge the battery. The Charging LED turns RED.
5. When the battery pack is fully charged, the Charging LED will turn GREEN.
6. Press the On/Off button to stop charging. Disconnect the battery pack connector from the charge connector.



CAUTION: If at any time during the charge process the battery pack(s) becomes hot to the touch, unplug the battery immediately and discontinue the charge process.

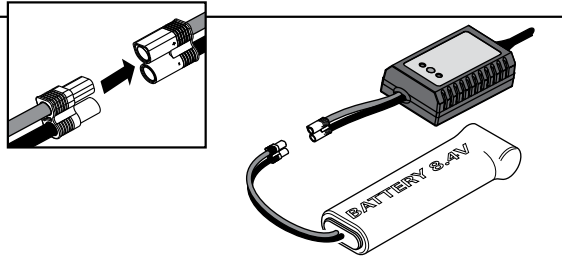

The vehicle battery charger produces 2000 milliAmps (2 Amps) per hour. Divide the mAh capacity on the label of a battery by 2000 to know how long battery charging will require. For example, a fully discharged 2400mAh battery requires 1.2 hours (72 minutes) to charge.

INITIAL CHARGE

Your Dynamite peak voltage detection charger includes safety circuitry and programming. The charger will stop charging after 15 minutes if it senses any issues that have come up in charging. The high electrical resistance commonly found in new, unconditioned, Ni-MH batteries can cause this safety circuit to turn off the charger before a full charging cycle is complete. This is commonly known as a "false peak" in your battery charge.

Should this occur during your first charge cycle, it does not necessarily indicate a failure of either your charger or battery. Instead, it shows that the charger is functioning properly and that the battery is not yet fully conditioned.

To complete your first full charging cycle in the event of a false peak, restart the charger by pressing the Start button again. Repeat this process until the charge cycle continues to charge past 15 minutes. It may take as many as 2 to 4 restarts to complete your first one or two

full charge cycles. Once your charger completes a charge cycle longer than 15 minutes, your battery will be fully charged. A typical first full charge cycle should run for 45 to 90 minutes, depending on the self-discharge condition of the battery since it was shipped from the factory.

Once your battery is properly conditioned through a few full charge and discharge cycles, you will see normal operation of the charger by a single press of the start button, followed by a 60- to 90-minute charge cycle.

CHARGING WARNINGS



WARNING: Failure to exercise caution while using this product and comply with the following warnings could result in product malfunction, electrical issues, excessive heat, FIRE, and ultimately injury and property damage.

- Read all safety precautions and literature prior to use of this product.
- Never leave the battery and charger unattended during use.
- Never allow children under 14 years of age to charge battery packs.
- Never attempt to charge dead or damaged batteries.
- Never charge a battery if the cable has been pinched or shorted.
- Never allow batteries or charger to come into contact with moisture at any time.
- Never charge batteries in extremely hot or cold places (recommended between 50–80°F (10–26°C)) or place in direct sunlight.
- Always use only Ni-MH rechargeable batteries. This charger cannot charge batteries such as "heavy duty", "alkaline", "mercury" or "lithium" battery.
- Always connect to the charger correctly.
- Always disconnect the battery and charger after charging and let them cool between charges.
- Always inspect the battery before charging.
- Always terminate all processes and contact Horizon Hobby if the product malfunctions.
- Always make sure you know the specifications of the battery to be charged or discharged to ensure it meets the requirements of this charger.
- Always constantly monitor the temperature of the battery pack while charging.
- Always end the charging process if the charger or battery becomes hot to the touch or starts to change form during the charge process.
- Always charge in a well ventilated area.

INSTALLING TRANSMITTER BATTERIES

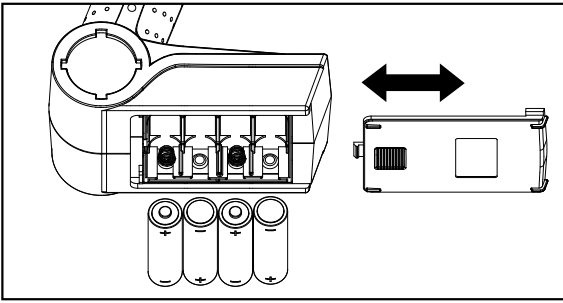

1. Slide the panel open on the bottom of the transmitter.
2. Obey the battery plus (+) and minus (-) diagram in the transmitter to install 4 AA batteries.
3. Slide the panel closed.

We recommend using only alkaline AA batteries in the transmitter.

⚠ CAUTION: If using rechargeable batteries, charge only rechargeable batteries. Charging non-rechargeable batteries may cause the batteries to burst, resulting in injury to persons and/or damage to property.

TRANSMITTER BATTERY SAFETY PRECAUTIONS

- Never install damaged batteries.
- Never install batteries of mixed types or of different ages in the transmitter.
- Always remove exhausted batteries.
- Always remove batteries before storing the transmitter.
- Low battery power can result in loss of control of the RC vehicle.

REMOVING THE VEHICLE BODY

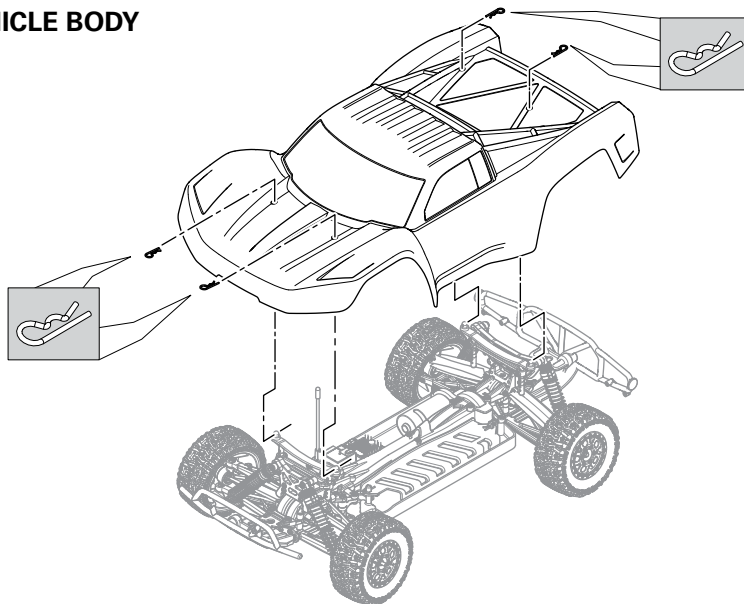

INSTALLING THE BATTERY IN THE VEHICLE

1. Remove the front and rear body clips, then remove the battery strap.
2. Install a fully charged battery.
3. Install the battery strap.
4. Install the front and rear body clips.

If desired, you can put foam blocks (ECX2015) in front of the battery so the weight of the battery increases rear traction or in back of the battery to increase steering response.

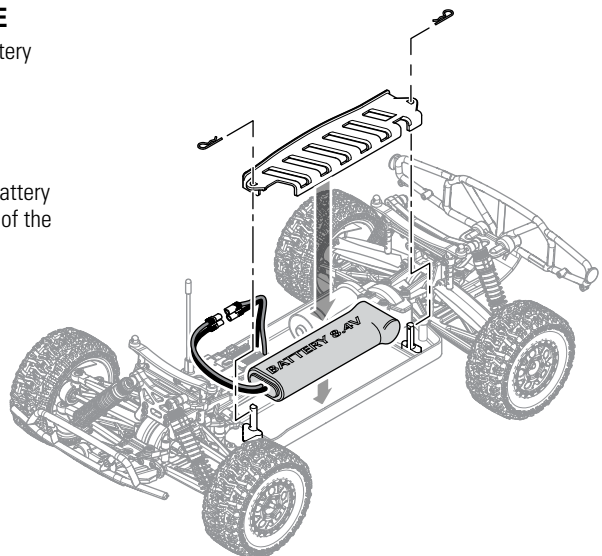

TRANSMITTER CONTROLS

REVERSE SWITCH

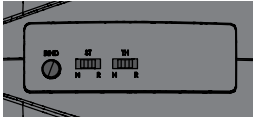

Allows you to change the direction of steering (ST. REV) and throttle (TH. REV) controls (default settings are "N" for steering and "N" for throttle).

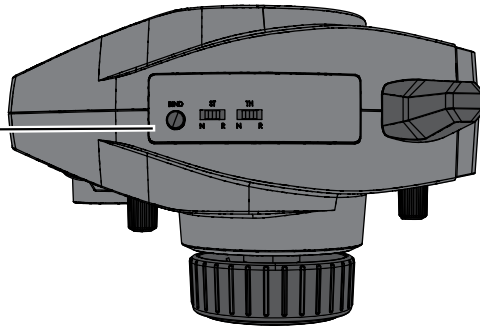

ST TRIM



Adjust to make the vehicle drive straight with no input at the steering wheel.

TH TRIM



Adjusts the neutral point of the electronic speed control.

ST RATE



Adjusts the amount the front wheels move when the steering wheel is turned left or right.

STEERING WHEEL

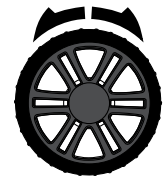

Control steering. Right and Left steering with ST. REV Switch on N (see ST. REV switch).

POWER SWITCH

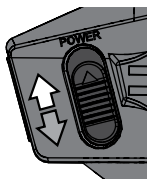

Power on or off the transmitter.

BATTERY LEVEL INDICATOR

 Solid Green: Battery voltage is good (above 4V).

 Flashing Green: Battery voltage is critically low (below 4V). Replace batteries.

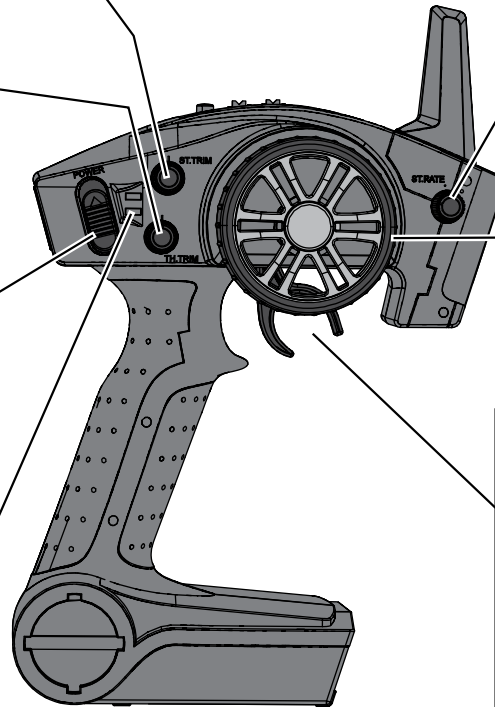

THROTTLE TRIGGER



Forward (when TH. REV switch on N).
Stop
Reverse (when TH. REV switch on N).

Controls power to motor for forward or reverse (see TH. REV switch).

CHANGING THE TRAVEL ADJUST SETTINGS

The travel function supports precise endpoint adjustments in each direction for the steering and throttle channels.

1. Hold the trigger in the full brake position while powering on the transmitter. The LED flashes rapidly, indicating the programming mode is active.
2. Throttle End Point: Hold the trigger in the full throttle position. Turn the TH TRIM knob to adjust the full throttle end point.
3. Brake End Point: Hold the trigger in the full brake position. Turn the TH TRIM knob to adjust the full brake end point. Return the trigger to the center position.
4. Left Steering End Point: Hold the steering wheel in the full left position. Turn the ST TRIM knob to adjust the left end point.
5. Right Steering End Point: Hold the steering wheel in the full right position. Turn the ST TRIM knob to adjust the right end point. Return the steering wheel to the center position.
6. Power off the transmitter to save the travel adjust settings. The minimum Travel is 75%, and the Maximum travel is 150%. The default travel settings are 125% steering and 100% throttle.

GETTING STARTED

1. Power on the transmitter.

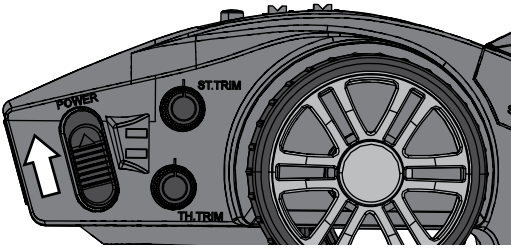

2. Power on the ESC.

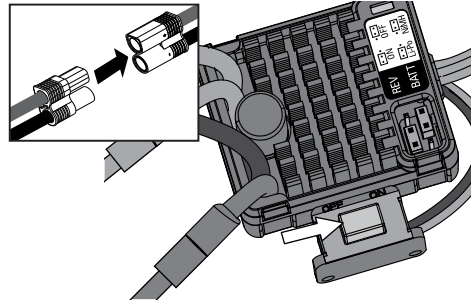

3. Do a test of the transmitter's control of the vehicle with the vehicle's wheels off the ground.

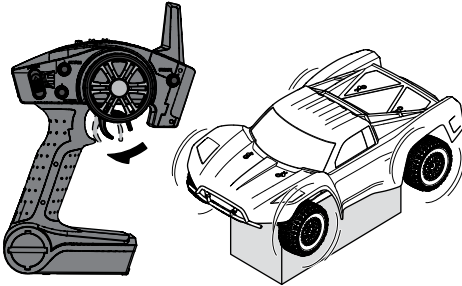

4. Start driving slowly, and, if the vehicle does not go straight, adjust the steering trim dial on the transmitter.

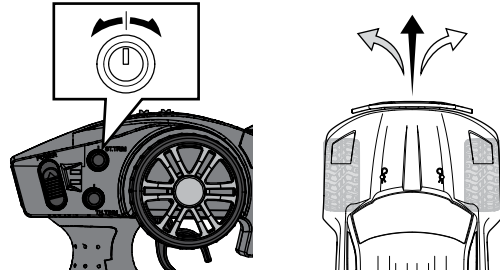

IMPORTANT: Seat the motor brushes by driving smoothly on a flat surface during use of the first battery charge. Properly seating the motor brushes will increase the life and performance of the motor.

INSTALLING THE VEHICLE BODY

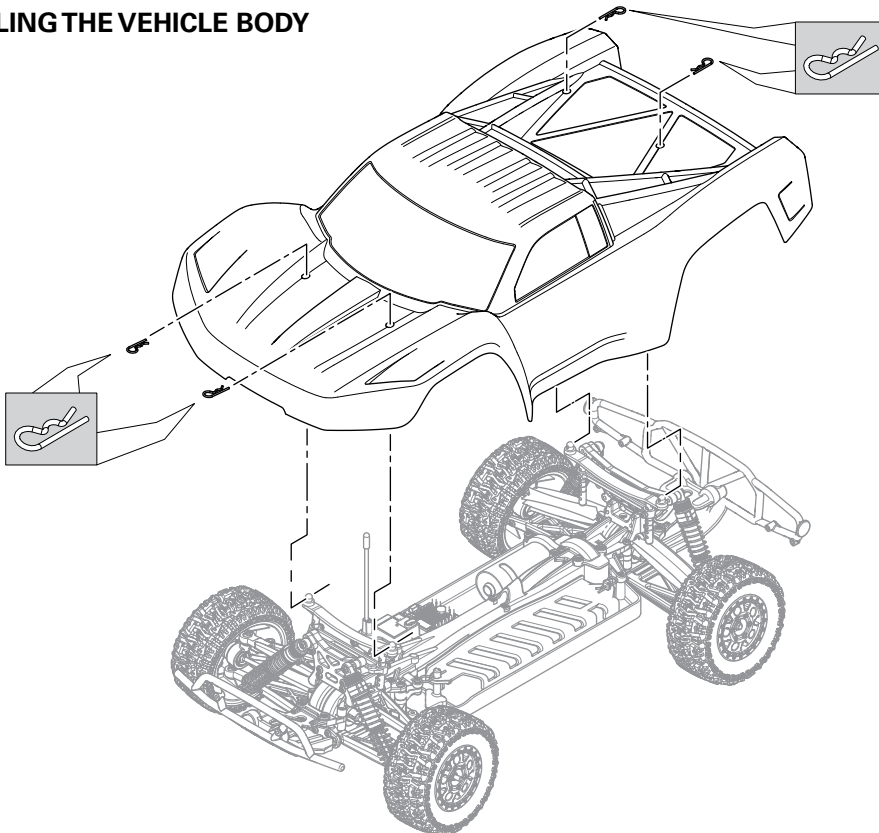

OPERATION

- ALWAYS turn on your transmitter before you turn on the receiver in the vehicle. Always power off the receiver before turning your transmitter off.
- ALWAYS operate your vehicle in a wide open area. Operating the vehicle in a small space or indoors can cause overheating at low speeds. Operating at low speed increases heat in the electronic speed control (ESC). Overheating can damage the vehicle and failure may result.

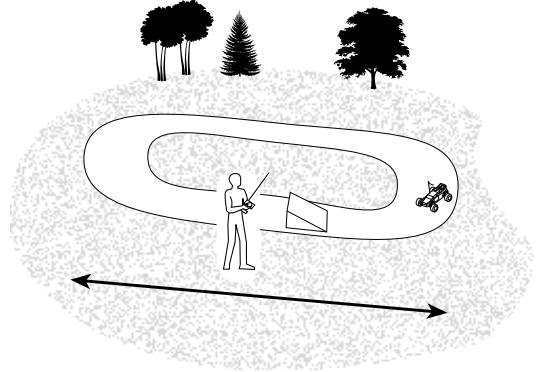
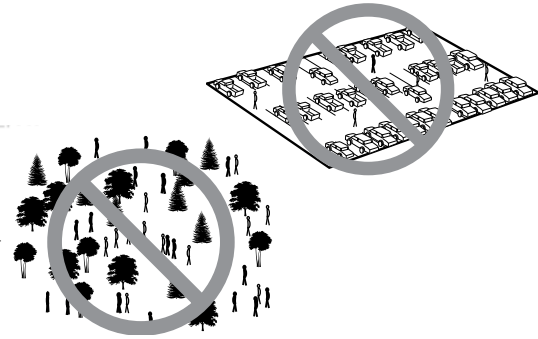

WHEN YOU ARE FINISHED

1. Power off the Electronic Speed Control (ESC).

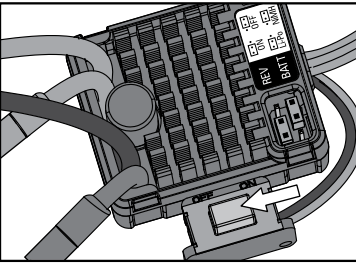

2. Disconnect the battery.

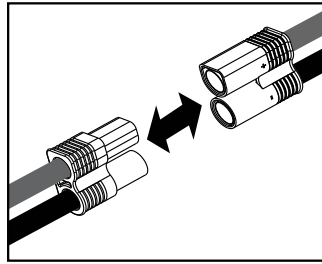

3. Power off the transmitter.

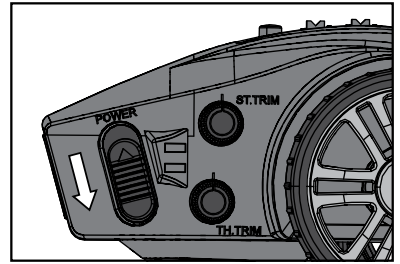

4. Remove the battery from the vehicle.

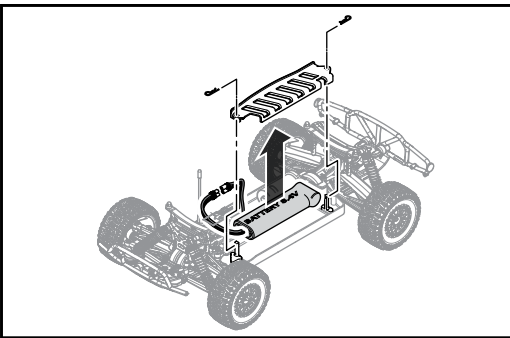

5. Recharge the battery.

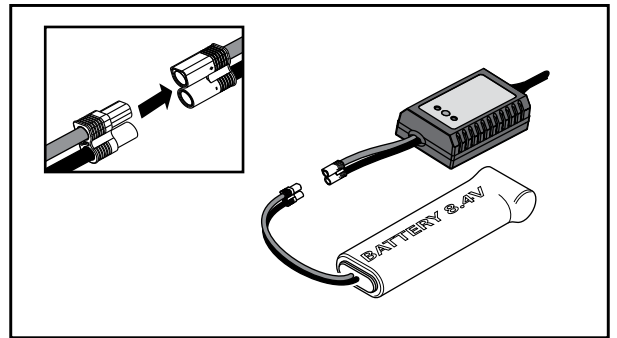

MOTOR CARE

- Seat the motor brushes by driving smoothly on a flat surface during use of the first battery charge. **Failing to do so can greatly reduce motor performance and functional life.**
- Prolong motor life by preventing overheating conditions. Undue motor wear results from frequent turns, stops and starts, pushing objects, driving in water and tall grass, and driving continuously up hill.
- Over-temperature protection is installed on the ESC to prevent circuit damage, but cannot protect the motor from driving against heavy resistance.

MAINTENANCE

ELECTRONIC SPEED CONTROL (ESC)

Programming: The ESC comes with two jumpers pre-installed in the REV: ON and BATT: Ni-MH configurations.

To disable reverse or change battery type to Li-Po, disconnect the jumper from the default port and connect it to the desired port. Power off the ESC, then power it back on.

If the jumpers are lost or not installed, the ESC will default to REV: ON and BATT: Li-Po.

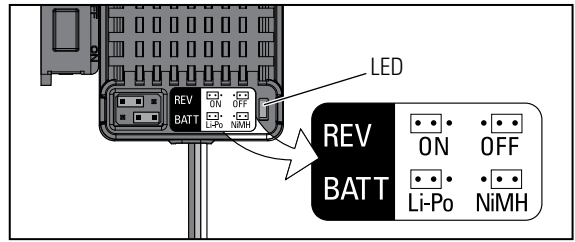

Operation	LED Status	Sound at Power UP
Stop	OFF	
Forward	Blinks	
Forward (full speed)	Solid	
Reverse	Blinks	
Brake	Blinks	
Brake (full brake)	Solid	
Ni-MH/Ni-Cd Battery		1 Short Beep
2S Li-Po Battery		2 Short Beeps
ESC Ready		1 Long Beep
Battery Low Voltage	Blinks	
Overheat	Blinks	

ELECTRICAL LAYOUT

Part #	Description
A	DYNS1215 Motor
B	DYN1062EC Battery 8.4V
C	SPMS603 Waterproof Steering Servo
D	SPMSR201 Waterproof Receiver
E	DYNS2211 Waterproof Electronic Speed Control (ESC)
F	Channel 1
G	Channel 2

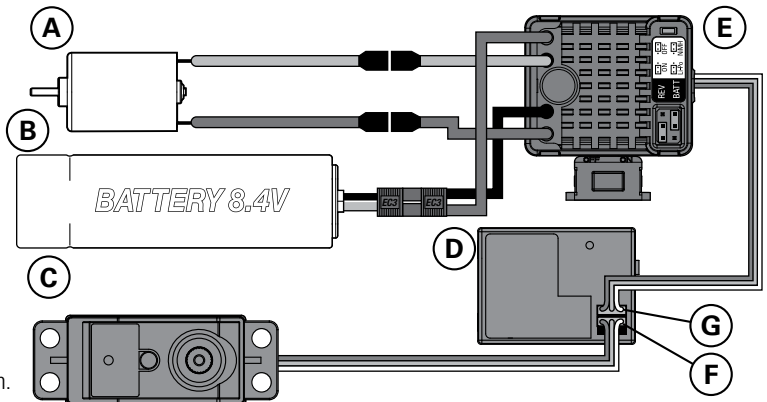

For correct operation, Channels 1 and 2 must be used as shown in the wiring diagram. The motor can be disconnected from the ESC at the connectors in the wiring.

SHOCK CLEANING

Oil-filled shocks will require regular maintenance due to the oil breaking down or getting dirty. This maintenance should be performed after about every 3 to 5 hours of use, depending on the conditions that the vehicle is used in.

- Remove the shock from the vehicle.
- Remove the cap from the shock body and dispose of fluid.
- Disassemble the shock. Clean thoroughly with DYN5505. Dry parts before assembly.
- Re-assemble the shock and refill the shock body with silicone fluid (30 weight recommended).
- Slowly move the shaft and piston up and down to remove air bubbles.
- Move the piston to the midway point of the body and install the cap.
- Wipe off any overflowing fluid.
- When properly filled, the piston should rebound about 3/8 in (9.5mm) after being pushed in fully.
- Re-install the shock on the vehicle.

Ride Height Adjustment

Ride height is an adjustment that affects the way the vehicle jumps, turns and goes over bumps. Drop one end of the vehicle from approximately 6 inches (152 mm) in height onto a flat surface. When dropping the front of the vehicle, after the vehicle settles, make sure the front arms are equal and parallel to the flat surface. Do the same with the rear to make sure both arms are parallel with the flat surface.

Lowering the front ride height increases steering, but decreases traction. Lowering the rear ride height increases traction, but decreases steering.

SHOCK PARTS DIAGRAM

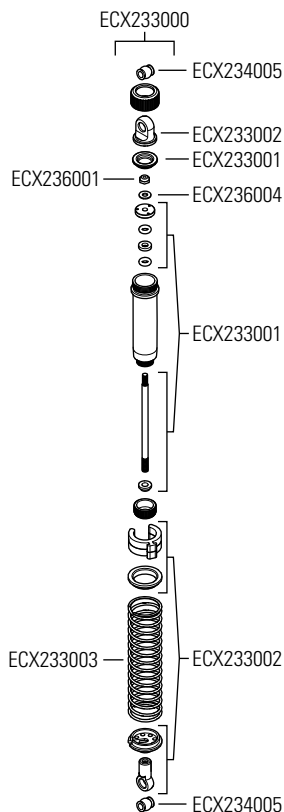

Part #	Description	Part #	Description
ECX233000	Shock, Complete, (2): 4wd	ECX234005	Link Set, Plastic: 1:10 4wd All
ECX233001	Shock Rebuild, (2): 4wd	ECX236001	Lock Nut, M2.5, (5)
ECX233002	Top, Bottom Shock Ends: 4wd	ECX236004	Special Hardware: 1:10 4wd All
ECX233003	Shock Spring, Black, Set: 4wd		

FASTENERS

Description	Description	Description	Description
Tapping Binder Head, M2.5x4mm	Tapping Binder Head, M3x22mm	Binder Head, M3x16mm	Setscrew, M3x3mm
Tapping Binder Head, M3x8mm	Tapping Binder Head, M3x25mm	Binder Head, M3x18mm	Setscrew, M4x3mm
Tapping Binder Head, M3x10mm	Tapping Flat Head, M2.5x10mm	Binder Head, M3x20mm	Washer, 6.2x10.8x0.2mm
Tapping Binder Head, M3x12mm	Tapping Flat Head, M3x10mm	Binder Head, M3x22mm	Washer, 3x8x1mm
Tapping Binder Head, M3x14mm	Tapping Flat Head, M3x15mm	Flat Head, M3x8mm	Washer, 2.6x6 X0.5mm
Tapping Binder Head, M3x16mm	Binder Head, M3x10mm	Flat Head, M3x10mm	Flanged Lock Nut, M4
Tapping Binder Head, M3x18mm	Binder Head, M3x12mm	Flat Head, M4x18mm	Lock Nut M3
Tapping Binder Head, M3x20mm	Binder Head, M3x14mm		Lock Nut M2.5

BINDING

Binding is the process of programming the receiver to recognize the GUID (Globally Unique Identifier) code of a single specific transmitter. The DX2E and SR201 receiver are bound at the factory. If you need to rebind, follow the instructions below.

1. With the receiver off, insert the bind plug into the BIND port on the receiver.
2. Power the receiver through any other port. The orange LED will flash continuously, indicating the receiver is in bind mode.
3. With the steering wheel and throttle trigger in the failsafe positions, normally full brakes and straight steering (see the Failsafe section on this page for more information), press and hold the bind button and turn on the transmitter. The green LED on the front of the transmitter will flash within three seconds, indicating the transmitter is in bind mode.
4. Release the bind button when the green LED flashes. Continue to hold the steering wheel and throttle trigger in the failsafe positions until the LED on the receiver glows solid.

Bind Button

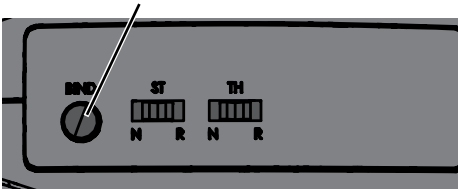

5. The LED on the receiver will glow solid when the transmitter and receiver are bound.
6. Remove the bind plug and store it in a convenient place.

You must rebind when:

- Different failsafe positions are desired e.g., when throttle or steering reversing has been changed.
 - Changing receiver types e.g., changing from a DSM® receiver to a DSMR®, DSM2® or Marine receiver.
 - Binding the receiver to a different transmitter.
- Some Spektrum receivers, like the SR3001, use a bind button rather than a bind plug. The binding process is the same with this receiver, however, instead of inserting the plug before powering up the receiver, press and hold the bind button while powering up the receiver to enter bind mode.

FAILSAFE

In the unlikely event that the radio link is lost during use, the receiver will drive the servos to their preprogrammed failsafe positions (normally full brakes and straight steering). If the receiver is turned on prior to turning on the transmitter, the receiver will enter failsafe mode, driving the servos to their preset failsafe positions. When the transmitter is turned on, normal control is resumed. Failsafe servo positions are set during binding (see binding a receiver above).

TROUBLESHOOTING GUIDE

Problem	Possible Cause	Solution
Short Run Time	<ul style="list-style-type: none"> • Battery damaged/not charged • Motor dirty or brushes worn 	<ul style="list-style-type: none"> • Check/change battery • Check/clean/replace
Sluggish Action	<ul style="list-style-type: none"> • Motor dirty or brushes worn • Bind in drivetrain • Vehicle battery is not charged 	<ul style="list-style-type: none"> • Check/clean/replace • Clean/adjust • Replace/recharge
Controls Reversed	<ul style="list-style-type: none"> • ST. REV or TH. REV 	<ul style="list-style-type: none"> • Change switch position
Motor/ESC overheat	<ul style="list-style-type: none"> • Over-gearred for the driving environment 	<ul style="list-style-type: none"> • Install smaller pinion
Doesn't Operate	<ul style="list-style-type: none"> • Transmitter batteries low • Transmitter powered off • ESC powered off • Vehicle battery is not charged 	<ul style="list-style-type: none"> • Replace/recharge • Power On • Power On • Replace/recharge
Poor Range	<ul style="list-style-type: none"> • Transmitter batteries low • Receiver antenna damaged 	<ul style="list-style-type: none"> • Replace/recharge • Check/repair/replace
The system will not connect	<ul style="list-style-type: none"> • Transmitter and receiver too near each other • Transmitter and receiver too near large metal objects (vehicles, etc.) • Receiver accidentally put in bind mode so receiver is no longer bound 	<ul style="list-style-type: none"> • Move transmitter 8–12 feet (2.4–3.6m) from receiver • Move away from large metal objects (vehicles, etc.) • Rebind transmitter and receiver
The receiver goes into failsafe mode a short distance away from the transmitter	<ul style="list-style-type: none"> • Check the receiver antenna to be sure it is not cut or damaged 	<ul style="list-style-type: none"> • Contact Horizon Product Support • Make sure receiver antenna is in an antenna tube and is above vehicle
The receiver quits responding during operation	<ul style="list-style-type: none"> • Low battery voltage • Loose or damaged wires or connectors between battery and receiver 	<ul style="list-style-type: none"> • Completely recharge battery • Do a check of the wires and connection between battery and receiver. Repair or replace wires and/or connectors
Receiver loses its bind	<ul style="list-style-type: none"> • Transmitter accidentally put in bind mode, ending bind to receiver 	<ul style="list-style-type: none"> • Bind transmitter to receiver

LIMITED WARRANTY

What this Warranty Covers

Horizon Hobby, LLC, (Horizon) warrants to the original purchaser that the product purchased (the "Product") will be free from defects in materials and workmanship at the date of purchase.

What is Not Covered

This warranty is not transferable and does not cover (i) cosmetic damage, (ii) damage due to acts of God, accident, misuse, abuse, negligence, commercial use, or due to improper use, installation, operation or maintenance, (iii) modification of or to any part of the Product, (iv) attempted service by anyone other than a Horizon Hobby authorized service center, (v) Product not purchased from an authorized Horizon dealer, or (vi) Product not compliant with applicable technical regulations.

OTHER THAN THE EXPRESS WARRANTY ABOVE, HORIZON MAKES NO OTHER WARRANTY OR REPRESENTATION, AND HEREBY DISCLAIMS ANY AND ALL IMPLIED WARRANTIES, INCLUDING, WITHOUT LIMITATION, THE IMPLIED WARRANTIES OF NON-INFRINGEMENT, MERCHANTABILITY AND FITNESS FOR A PARTICULAR PURPOSE. THE PURCHASER ACKNOWLEDGES THAT THEY ALONE HAVE DETERMINED THAT THE PRODUCT WILL SUITABLY MEET THE REQUIREMENTS OF THE PURCHASER'S INTENDED USE.

Purchaser's Remedy

Horizon's sole obligation and purchaser's sole and exclusive remedy shall be that Horizon will, at its option, either (i) service, or (ii) replace, any Product determined by Horizon to be defective. Horizon reserves the right to inspect any and all Product(s) involved in a warranty claim. Service or replacement decisions are at the sole discretion of Horizon. Proof of purchase is required for all warranty claims. SERVICE OR REPLACEMENT AS PROVIDED UNDER THIS WARRANTY IS THE PURCHASER'S SOLE AND EXCLUSIVE REMEDY.

Limitation of Liability

HORIZON SHALL NOT BE LIABLE FOR SPECIAL, INDIRECT, INCIDENTAL OR CONSEQUENTIAL DAMAGES, LOSS OF PROFITS OR PRODUCTION OR COMMERCIAL LOSS IN ANY WAY, REGARDLESS OF WHETHER SUCH CLAIM IS BASED IN CONTRACT, WARRANTY, TORT, NEGLIGENCE, STRICT LIABILITY OR ANY OTHER THEORY OF LIABILITY, EVEN IF HORIZON HAS BEEN ADVISED OF THE POSSIBILITY OF SUCH DAMAGES. Further, in no event shall the liability of Horizon exceed the individual price of the Product on which liability is asserted. As Horizon has no control over use, setup, final assembly, modification or misuse, no liability shall be assumed nor accepted for any resulting damage or injury. By the act of use, setup or assembly, the user accepts all resulting liability. If you as the purchaser or user are not prepared to accept the liability associated with the use of the Product, purchaser is advised to return the Product immediately in new and unused condition to the place of purchase.

Law

These terms are governed by Illinois law (without regard to conflict of law principals). This warranty gives you specific legal rights, and you may also have other rights which vary from state to state. Horizon reserves the right to change or modify this warranty at any time without notice.

WARRANTY SERVICES

Questions, Assistance, and Services

Your local hobby store and/or place of purchase cannot provide warranty support or service. Once assembly, setup or use of the Product has been started, you must contact your local distributor or Horizon directly. This will enable Horizon to better answer your questions and service you in the event that you may need any

assistance. For questions or assistance, please visit our website at www.horizonhobby.com, submit a Product Support Inquiry, or call the toll free telephone number referenced in the Warranty and Service Contact Information section to speak with a Product Support representative.

Inspection or Services

If this Product needs to be inspected or serviced and is compliant in the country you live and use the Product in, please use the Horizon Online Service Request submission process found on our website or call Horizon to obtain a Return Merchandise Authorization (RMA) number. Pack the Product securely using a shipping carton. Please note that original boxes may be included, but are not designed to withstand the rigors of shipping without additional protection. Ship via a carrier that provides tracking and insurance for lost or damaged parcels, as Horizon is not responsible for merchandise until it arrives and is accepted at our facility. An Online Service Request is available at http://www.horizonhobby.com/content/_service-center_render-service-center. If you do not have internet access, please contact Horizon Product Support to obtain a RMA number along with instructions for submitting your product for service. When calling Horizon, you will be asked to provide your complete name, street address, email address and phone number where you can be reached during business hours. When sending product into Horizon, please include your RMA number, a list of the included items, and a brief summary of the problem. A copy of your original sales receipt must be included for warranty consideration. Be sure your name, address, and RMA number are clearly written on the outside of the shipping carton.

NOTICE: Do not ship LiPo batteries to Horizon. If you have any issue with a LiPo battery, please contact the appropriate Horizon Product Support office.

Warranty Requirements

For Warranty consideration, you must include your original sales receipt verifying the proof-of-purchase date. Provided warranty conditions have been met, your Product will be serviced or replaced free of charge. Service or replacement decisions are at the sole discretion of Horizon.

Non-Warranty Service

Should your service not be covered by warranty, service will be completed and payment will be required without notification or estimate of the expense unless the expense exceeds 50% of the retail purchase cost. By submitting the item for service you are agreeing to payment of the service without notification. Service estimates are available upon request. You must include this request with your item submitted for service. Non-warranty service estimates will be billed a minimum of ½ hour of labor. In addition you will be billed for return freight. Horizon accepts money orders and cashier's checks, as well as Visa, MasterCard, American Express, and Discover cards. By submitting any item to Horizon for service, you are agreeing to Horizon's Terms and Conditions found on our website http://www.horizonhobby.com/content/_service-center_render-service-center.

ATTENTION: Horizon service is limited to Product compliant in the country of use and ownership. If received, a non-compliant Product will not be serviced. Further, the sender will be responsible for arranging return shipment of the un-serviced Product, through a carrier of the sender's choice and at the sender's expense. Horizon will hold non-compliant Product for a period of 60 days from notification, after which it will be discarded.

CONTACT INFORMATION

Country of Purchase	Horizon Hobby	Contact Information	Address
United States of America	Horizon Service Center (Repairs and Repair Requests)	servicecenter.horizonhobby.com/ RequestForm/	4105 Fieldstone Rd Champaign, Illinois, 61822 USA
	Horizon Product Support (Product Technical Assistance)	www.quickbase.com/db/ bghj7ey8c?a=GenNewRecord 888-959-2306	
	Sales	sales@horizonhobby.com 888-959-2306	
United Kingdom	Service/Parts/Sales: Horizon Hobby Limited	sales@horizonhobby.co.uk +44 (0) 1279 641 097	Units 1–4 , Ployters Rd, Staple Tye Harlow, Essex, CM18 7NS, United Kingdom
Germany	Horizon Technischer Service Sales: Horizon Hobby GmbH	service@horizonhobby.de +49 (0) 4121 2655 100	Christian-Junge-Straße 1 25337 Elmshorn, Germany
France	Service/Parts/Sales: Horizon Hobby SAS	infofrance@horizonhobby.com +33 (0) 1 60 18 34 90	11 Rue Georges Charpak 77127 Lieusaint, France
China	Service/Parts/Sales: Horizon Hobby – China	info@horizonhobby.com.cn +86 (021) 5180 9868	Room 506, No. 97 Changshou Rd. Shanghai, China 200060

FCC INFORMATION

This device complies with part 15 of the FCC rules. Operation is subject to the following two conditions: (1) This device may not cause harmful interference, and (2) this device must accept any interference received, including interference that may cause undesired operation.

⚠ CAUTION: Changes or modifications not expressly approved by the party responsible for compliance could void the user's authority to operate the equipment.

This product contains a radio transmitter with wireless technology which has been tested and found to be compliant with the applicable regulations governing a radio transmitter in the 2.400GHz to 2.4835GHz frequency range.

Antenna Separation Distance

When operating your Spektrum transmitter, please be sure to

maintain a separation distance of at least 5 cm between your body (excluding fingers, hands, wrists, ankles and feet) and the antenna to meet RF exposure safety requirements as determined by FCC regulations.

The following illustrations show the approximate 5 cm RF exposure area and typical hand placement when operating your Spektrum transmitter.

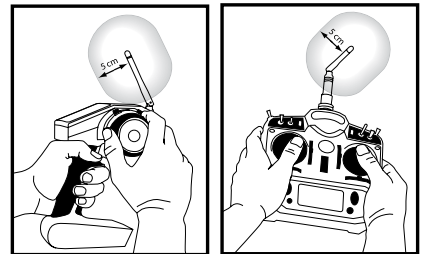

IC INFORMATION

This device complies with Industry Canada license-exempt RSS standard(s). Operation is subject to the following two conditions:

(1) this device may not cause interference, and (2) this device must accept any interference, including interference that may cause undesired operation of the device.

COMPLIANCE INFORMATION FOR THE EUROPEAN UNION

AT	BE	BG	CZ	CY	DE	DK
EE	ES	FI	FR	GR	HR	HU
IE	IT	LT	LU	LV	MT	NL
PL	PT	RO	SE	SI	SK	UK
IS	LI	NO	CH			

Declaration of Conformity

(in accordance with ISO/IEC 17050-1)

No. HH2014012401

Product(s): ECX Torment 1:10 4WD SCT Brushed RTR
(Spektrum DX2E transmitter and SR201 receiver included)

Item Number(s): ECX03013I

Equipment class: 2

The object of declaration described above is in conformity with the requirements of the specifications listed below, following the provisions of the European R&TTE Directive 1999/5/EC, EMC Directive 2004/108/EC and LVD Directive 2006/95/EC:

EN 300-328 V1.7.1: 2006**EN 301 489-1 V1.9.2: 2012****EN301 489-17 V2.1.1: 2009****EN60950-1:2006+A11:2009+A1:2010+A12: 2011****EN55022:2010 + AC:2011****EN55024:2010****EN61000-3-2:2006+A1:2009+A2:2009****EN61000-3-3:2008**

Signed for and on behalf of:
Horizon Hobby, LLC
Champaign, IL USA
Jan. 24, 2014

Robert Peak
Chief Financial Officer
Horizon Hobby, Inc.

**Instructions for disposal of WEEE by users in the European Union**

This product must not be disposed of with other waste. Instead, it is the user's responsibility to dispose of their waste equipment by handing it over to a designated collection point for the recycling of waste electrical and electronic equipment. The separate collection and recycling of your waste equipment at the time of disposal will help to conserve natural resources and ensure that it is recycled in a manner that protects human health and the environment. For more information about where you can drop off your waste equipment for recycling, please contact your local city office, your household waste disposal service or where you purchased the product.