



Instruction Manual

Thank you for choosing the Dynamite® brand. We know that you, the customer, are the reason we are in business. Your satisfaction is our number one priority. With this in mind, we have produced this product to be of the highest quality, performance and reliability, and at a “value-packed” price. We hope it provides you with hours of enjoyment in your next RC project.

Features

- Compatible with Ni-Cd/Ni-MH and Li-Po/Li-Ion batteries.
- Pre-wired with bullet-style motor connectors and universal receiver plug that fits most popular radio systems.
- Designed to operate with non-sensored brushless motors and stock brushed motors.
- Programming allows easy interface to change settings from the throttle trigger on your transmitter or with the use of the Fuze™ programming card.

Mounting the Speed Control

Mount the Fuze ESC in the location specified by your vehicle's instruction manual. Use the double-sided foam tape (included) to secure the speed control in position.

NOTE: Be sure all wiring connections can be reached prior to mounting.

Use double-sided foam tape to secure the side of the switch to a convenient location on the chassis or shock tower.

Specifications

1/18 (DYN3740)

Operation	Proportional forward, proportional reverse with braking delay
Input Voltage.....	6–9 cell Ni-Cd/Ni-MH 2S–3S Li-Po/Li-Ion
Peak Current	50 amperes
Continuous Current.....	35 amperes
BEC Output	6V
Overload Protection.....	Thermal
Dimensions.....	37mm x 25mm
Weight.....	40 g

1/10 and Short Course (DYN3741)

Operation	Proportional forward, proportional reverse with braking delay
Input Voltage.....	6–9 cell Ni-Cd/Ni-MH 2S–3S Li-Po/Li-Ion
Peak Current	100 amperes
Continuous Current.....	70 amperes
BEC Output	6V
Overload Protection.....	Thermal
Dimensions.....	42mm x 37mm
Weight.....	120 g

Wiring Diagram - Brushless Motors

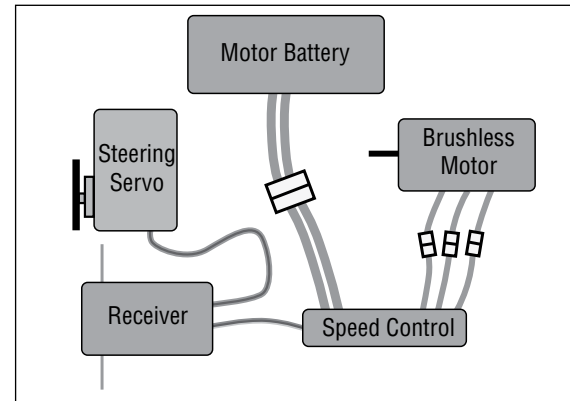

Wiring Diagram - Brushed Motors

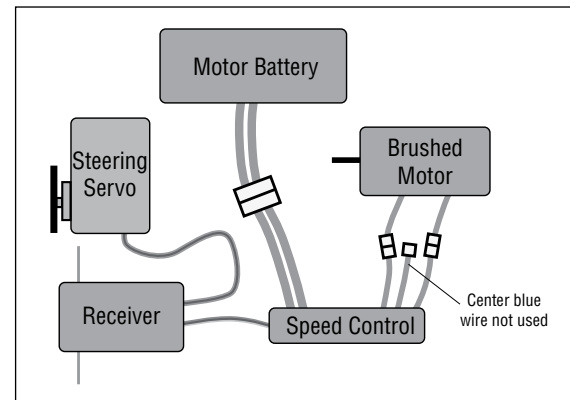

Quick Start Guide

The quick start setup guide will get you running quickly using the ESC's default settings.

1. Solder a high-quality battery connector to the ESC.
2. Mount the ESC and motor into the car.
3. Plug in the 3 motor wires to the 3 motor wires on the ESC (brushless applications). For brushed motor applications, the center blue wire is not used.
4. Plug in the ESC receiver lead to CH2 on your receiver.
5. Make sure the ESC's switch is OFF.
6. Plug a battery into the ESC.

Throttle/System Calibration Procedure

1. Turn on the transmitter.
2. While holding full throttle on your transmitter, turn the ESC switch ON.
 - A. After a few seconds you'll hear 6 tones created by the motor.
 - B. Release the throttle to the neutral position and after a few seconds you'll hear 4 tones.
 - C. Apply full brake position and after a few seconds you'll hear 4 tones.
 - D. Turn the ESC switch off.
 - E. Turn on the ESC switch. A few seconds later the ESC will arm with 3 rising tones followed by 4 short tones. You're ready to go!
 - F. If the motor operates in the wrong direction simply reverse any two of the motor wires.
 - G. Always disconnect the battery from the ESC when you have finished operating your vehicle. The ESC's switch only controls the power to the receiver and servos. The ESC will continue to draw current from the battery even with the switch in the OFF position. Over time the battery will completely discharge causing possible damage.

ESC Functions and Modes

The Fuze ESC allows you to customize the way your vehicle performs on the track.

Take your time to familiarize yourself with many settings so you will be ready to adjust the ESC for changing conditions.

Function

1. Brake Mode: There are 8 available options in the brake mode. These allow you to choose from 0%, 20%, 40%, 60%, 70%, 80%, 90%, and 100% brake strength.
2. Drag Brake Mode: There are 8 available options in the drag brake mode. These allow you to choose from 0%, 5%, 10%, 15%, 20%, 25%, 30%, and 80% drag brake strength.
3. Throttle Speed: There are 5 available options in the throttle speed sensitivity mode. They are very soft, soft, standard, quick, and very quick.
4. Start Power: There are 5 available options in the start-up motor timing settings. They are very soft, soft, standard, powerful and very powerful. The more powerful start speeds offer quick and powerful motor output from a complete stop. This function is ideal when used for high or low traction conditions.
5. Reverse Power: There are 8 available options in the reverse mode. These allow you to choose from 0%, 20%, 40%, 60%, 70%, 80%, 90%, and 100% reverse power.
6. Forward/Reverse Run Mode: There are 5 different options in the forward/reverse run mode. They are forward only, 2 stage reverse, 2 stage reverse with safe brake, reverse with 1 second delay, reverse with 1 second delay and safe brake.
7. Motor Timing: There are 4 options available in this function that allow you to adjust motor timing to maximize your motor's performance. The options are: auto, low, standard and advanced. Advanced timing offers maximum power output at the expense of efficiency and run time.

8. Battery Management System: The battery management system allows you to protect your batteries from damage due to over-discharge. 6 total options are available, 3 for Li-Po/Li-Ion batteries and 3 for Ni-Cd/Ni-MH batteries.
9. Thermal Protection System: The Fuze ESC has a built-in thermal overload to protect the ESC from high operating temperatures and is not user programmable. If the ESC reaches 248°F (120°C) the ESC will shut down until it can cool to an acceptable operating temperature. If thermal shutdowns occur often, change to a smaller pinion gear size or a motor with a lower Kv rating.

Factory Default Settings

1. 100% Brake
2. 0% Drag Brake
3. Standard Throttle Sensitivity
4. Very Soft Start Power
5. 60% Reverse Power
6. 2 Stage Reverse with Safe Brake
7. Auto Motor Timing
8. Ni-MH Battery (4.5V Cutoff)

ESC Programming Procedure

Programming can be accomplished using the radio transmitter or handheld quick programming card.

Transmitter Controlled Programming

1. Initialize system calibration. Leave the ESC power ON after step 2-C of calibration, bringing the ESC into the transmitter controlled programming mode.
2. The programming sequence will always be presented in sequential order beginning with function #1 (brake mode).

Function #1 Brake Mode:

In brake mode the motor will produce 1 beep signifying brake mode. 1 to 8 beeps follow signifying the available options.

1-1...beep-beep	0% brake strength
1-2...beep-2 beeps	20% brake strength
1-3...beep-3 beeps	40% brake strength
1-4...beep-4 beeps	60% brake strength
1-5...beep-5 beeps	70% brake strength
1-6...beep-6 beeps	80% brake strength
1-7...beep-7 beeps	90% brake strength
1-8...beep-8 beeps	100% brake strength (factory default)

Once the series of beeps for the option you wish to choose has completed, move the throttle position to maximum and release to neutral. You will receive a 4-beep confirmation of programming. If at this time you do not wish to proceed to function #2, you can simply shut the power off to the ESC.

Function #2 Drag Brake Mode:

In drag brake mode the motor will produce 2 beeps signifying drag brake mode. The following 1 to 8 beeps signify the available options.

2-1...2 beeps-beep	0% drag brake (factory default)
2-2...2 beeps-2 beeps	5% drag brake
2-3...2 beeps-3 beeps	10% drag brake
2-4...2 beeps-4 beeps	15% drag brake
2-5...2 beeps-5 beeps	20% drag brake
2-6...2 beeps-6 beeps	25% drag brake
2-7...2 beeps-7 beeps	30% drag brake
2-8...2 beeps-8 beeps	80% drag brake

Once the series of beeps for the option you wish to choose has completed, move the throttle position to maximum and release to neutral. You will receive a 4-beep confirmation of programming. If at this time you do not wish to proceed to function #3, you can simply shut the power off to the ESC.

Function #3 Throttle Speed:

In throttle speed mode the motor will produce 3 beeps signifying throttle speed mode. The following 1 to 5 beeps signify the available options.

3-1...3 beeps-beep	very soft throttle sensitivity
3-2...3 beeps-2 beeps	soft throttle sensitivity
3-3...3 beeps-3 beeps	standard throttle sensitivity (factory default)
3-4...3 beeps-4 beeps	quick throttle sensitivity
3-5...3 beeps-5 beeps	very quick throttle sensitivity

Once the series of beeps for the option you wish to choose has completed, move the throttle position to maximum and release to neutral. You will receive a 4-beep confirmation of programming. If at this time you do not wish to proceed to function #4, you can simply shut the power off to the ESC.

Function #4 Start Power:

In start power mode the motor will produce 4 beeps signifying start power mode. The following 1 to 5 beeps signify the available options.

4-1...4 beeps-beep	very soft starting power (factory default)
4-2...4 beeps-2 beeps	soft starting power
4-3...4 beeps-3 beeps	standard starting power
4-4...4 beeps-4 beeps	powerful starting power
4-5...4 beeps-5 beeps	very powerful starting power

Once the series of beeps for the option you wish to choose has completed, move the throttle position to maximum and release to neutral. You will receive a 4-beep confirmation of programming. If at this time you do not wish to proceed to function #5, you can simply shut the power off to the ESC.

Function #5 Reverse Power:

In reverse power mode the motor will produce 5 beeps signifying reverse power mode. The following 1 to 8 beeps signify the available options.

5-1...5 beeps-beep	0% reverse power
5-2...5 beeps-2 beeps	20% reverse power
5-3...5 beeps-3 beeps	40% reverse power
5-4...5 beeps-4 beeps	60% reverse power (factory default)
5-5...5 beeps-5 beeps	70% reverse power
5-6...5 beeps-6 beeps	80% reverse power
5-7...5 beeps-7 beeps	90% reverse power
5-8...5 beeps-8 beeps	100% reverse power

Once the series of beeps for the option you wish to choose has completed, move the throttle position to maximum and release to neutral. You will receive a 4-beep confirmation of programming. If at this time you do not wish to proceed to function #6, you can simply shut the power off to the ESC.

Function #6 Forward/Reverse Run Mode:

In forward/reverse run mode the motor will produce 6 beeps signifying reverse power mode. The following 1 to 5 beeps signify the available options.

6-1...6 beeps-beep	forward only with brake
6-2...6 beeps-2 beeps	forward, brake and 2-stage reverse
6-3...6 beeps-3 beeps	forward, brake, 2-stage reverse, safe brake (factory default)
6-4...6 beeps-4 beeps	forward, brake, reverse with 1sec. delay
6-5...6 beeps-5 beeps	forward, brake, reverse with 1sec. delay, safe brake

Once the series of beeps for the option you wish to choose has completed, move the throttle position to maximum and release to neutral. You will receive a 4-beep confirmation of

programming. If at this time you do not wish to proceed to function #7, you can simply shut the power off to the ESC.

Function #7 Motor Timing:

In motor timing mode the motor will produce 7 beeps signifying motor timing mode. The following 1 to 4 beeps signify the available options.

7-1...7 beeps-beep	auto motor timing (factory default)
7-2...7 beeps-2 beeps	low motor timing
7-3...7 beeps-3 beeps	standard motor timing
7-4...7 beeps-4 beeps	advanced motor timing

Once the series of beeps for the option you wish to choose has completed, move the throttle position to maximum and release to neutral. You will receive a 4-beep confirmation of programming. If at this time you do not wish to proceed to function #8, you can simply shut the power off to the ESC.

Function #8 Battery Management System:

In battery management system mode the motor will produce 8 beeps signifying battery management system mode. The following 1 to 6 beeps signify the available options.

8-1...8 beeps-beep	Ni-Cd/Ni-MH 4.5V cutoff (factory default)
8-2...8 beeps-2 beeps	Ni-Cd/Ni-MH 4.2V cutoff
8-3...8 beeps-3 beeps	Ni-Cd/Ni-MH 3.9V cutoff
8-4...8 beeps-4 beeps	Li-Po/Li-Ion light discharge
8-5...8 beeps-5 beeps	Li-Po/Li-Ion standard discharge
8-6...8 beeps-6 beeps	Li-Po/Li-Ion heavy discharge

Once the series of beeps for the option you wish to choose has completed, move the throttle position to maximum and release to neutral. You will receive a 4-beep confirmation of programming. At this time turn off the ESC power.

More About the Battery Management System

This section will give you a few more details regarding the smart battery management system. The low voltage cutoff is based on the type of battery, battery voltage, cell count (for Li-Po/Li-ion modes which the ESC recognizes at power up) and battery voltage under load. The low voltage cutoff occurs in 2 steps.

Step 1: The motor's power will be reduced in order to alert the user that the battery is about to reach the cutoff point.

Step 2: Once the battery reaches the low voltage cutoff point, the motor will shut down completely. In order to protect your battery, do not resume operation. Shut the vehicle off and install a fully charged battery.

The following will show the low voltage cutoff levels:

8-1... Ni-Cd/Ni-MH 4.5V cutoff (factory default)
8-2... Ni-Cd/Ni-MH 4.2V cutoff
8-3... Ni-Cd/Ni-MH 3.9V cutoff
8-4... Li-Po/Li-Ion light discharge Step 1-3.2V per cell, Step 2-2.9V per cell
8-5... Li-Po/Li-Ion standard discharge Step 1-2.9V per cell, Step 2-2.6V per cell
8-6... Li-Po/Li-Ion heavy discharge Step 1-2.6V per cell, Step 2-2.3V per cell

Programming Using the Quick Programming Card

The easiest way to program your Fuze ESC is by using the Handheld Quick Programming Card (DYN3745).

Using the Quick Programming Card allows you to go directly into the mode setting that you wish to change without waiting through any of the functions that precede it.

1. Remove the ESC receiver lead from the receiver and connect it to the programming card. Be sure to observe correct polarity.
2. Connect a battery to the ESC.
3. Turn on the ESC. You will hear 6 beeps followed by one rising tone. You have now entered into programming mode.
4. Using the black buttons on the front of the card, enter the function number (listed on the front of the card) followed by the option number (listed on the back of the card) that you wish to choose. For example, if you wish to adjust the brake strength to 80% and drag brake to 10%: press button #1 followed by button #6. After about 1 second you will hear 1 long tone followed by 6 beeps confirming the programming setting. Next you will hear 1 rising tone which allows you to enter the next setting. Press button #2 followed by button #3. After about 1 second you will hear 2 long tones followed by 3 beeps confirming the programming setting. Once again you will hear 1 rising tone. You can either enter into another function for modification or simply turn off the power to the ESC to end programming.
5. Disconnect the ESC receiver lead from the programming card.
6. Connect the ESC receiver lead to the receiver.

Troubleshooting Guide

Symptom	Solution
Steering servo operates but the motor does not run	Programming is not complete. Reprogram the ESC by following the programming instructions. Speed control connected to receiver incorrectly. Refer to manufacturer's instructions. Motor defective. Test motor independently, repair or replace as needed. Low batteries. Charge as needed. Overload Protection enabled. Check motor and connections.
Steering and motor do not function	Receiver wired incorrectly. Check polarity and orientation of control plugs. Radio inoperational. See radio instruction manual. Batteries discharged. Recharge or replace.
Full speed not attainable	Battery has reached the programmed low voltage cutoff. Transmitter adjusted improperly. See radio instructions for proper adjustment. ESC programmed incorrectly. Reprogram.
Motor slows but will not stop	Throttle trim may be set improperly. See radio instruction manual. ESC program does not match transmitter. Reprogram ESC.
Reduced radio range/Interference	Transmitter antenna is not fully extended. Motor capacitors broken/missing. Repair or replace. (Brushed motors only) Motor noise. Move receiver further away from ESC, motor and wiring. Transmitter batteries low. Replace batteries. Interference transmitted on or near radio frequency. Move to a different location and/or change radio channels (see manufacturer's instructions).

Warranty Period

Exclusive Warranty- Horizon Hobby, Inc., (Horizon) warranties that the Products purchased (the "Product") will be free from defects in materials and workmanship at the date of purchase by the Purchaser.

Limited Warranty

(a) This warranty is limited to the original Purchaser ("Purchaser") and is not transferable. REPAIR OR REPLACEMENT AS PROVIDED UNDER THIS WARRANTY IS THE EXCLUSIVE REMEDY OF THE PURCHASER. This warranty covers only those Products purchased from an authorized Horizon dealer. Third party transactions are not covered by this warranty. Proof of purchase is required for warranty claims. Further, Horizon reserves the right to change or modify this warranty without notice and disclaims all other warranties, express or implied.

(b) Limitations- HORIZON MAKES NO WARRANTY OR REPRESENTATION, EXPRESS OR IMPLIED, ABOUT NON-INFRINGEMENT, MERCHANTABILITY OR FITNESS FOR A PARTICULAR PURPOSE OF THE PRODUCT. THE PURCHASER ACKNOWLEDGES THAT THEY ALONE HAVE DETERMINED THAT THE PRODUCT WILL SUITABLY MEET THE REQUIREMENTS OF THE PURCHASER'S INTENDED USE.

(c) Purchaser Remedy- Horizon's sole obligation hereunder shall be that Horizon will, at its option, (i) repair or (ii) replace, any Product determined by Horizon to be defective. In the event of a defect, these are the Purchaser's exclusive remedies. Horizon reserves the right to inspect any and all equipment involved in a warranty claim. Repair or replacement decisions are at the sole discretion of Horizon. This warranty does not cover cosmetic damage or damage due to acts of God, accident, misuse, abuse, negligence, commercial use, or modification of or to any part of the Product. This warranty does not cover damage due to improper installation, operation, maintenance, or attempted repair by anyone other than Horizon. Return of any goods by Purchaser must be approved in writing by Horizon before shipment.

Damage Limits

HORIZON SHALL NOT BE LIABLE FOR SPECIAL, INDIRECT OR CONSEQUENTIAL DAMAGES, LOSS OF PROFITS OR PRODUCTION OR COMMERCIAL LOSS IN ANY WAY CONNECTED WITH THE PRODUCT, WHETHER SUCH CLAIM IS BASED IN CONTRACT, WARRANTY, NEGLIGENCE, OR STRICT LIABILITY. Further, in no event shall the liability of Horizon exceed the individual price of the Product on which liability is asserted. As Horizon has no control over use, setup, final assembly, modification or misuse, no liability shall be assumed nor accepted for any resulting damage or injury. By the act of use, setup or assembly, the user accepts all resulting liability.

If you as the Purchaser or user are not prepared to accept the liability associated with the use of this Product, you are advised to return this Product immediately in new and unused condition to the place of purchase.

Law: These Terms are governed by Illinois law (without regard to conflict of law principals).

Safety Precautions

This is a sophisticated hobby Product and not a toy. It must be operated with caution and common sense and requires some basic mechanical ability. Failure to operate this Product in a safe and responsible manner could result in injury or damage to the Product or other property. This Product is not intended for use by children without direct adult supervision. The Product manual contains instructions for safety, operation and maintenance. It is essential to read and follow all the instructions and warnings in the manual, prior to assembly, setup or use, in order to operate correctly and avoid damage or injury.

Questions, Assistance, and Repairs

Your local hobby store and/or place of purchase cannot provide warranty support or repair. Once assembly, setup or use of the Product has been started, you must contact Horizon directly. This will enable Horizon to better answer your questions and service you in the event that you may need any assistance. For questions or assistance, please direct your email to productsupport@horizonhobby.com, or call 877.504.0233 toll free to speak to a service technician.

Inspection or Repairs

If this Product needs to be inspected or repaired, please call for a Return Merchandise Authorization (RMA). Pack the Product securely using a shipping carton. Please note that original boxes may be included, but are not designed to withstand the rigors of shipping without additional protection. Ship via a carrier that provides tracking and insurance for lost or damaged parcels, as Horizon is not responsible for merchandise until it arrives and is accepted at our facility. A Service Repair Request is available at www.horizonhobby.com on the "Support" tab. If you do not have internet access, please include a letter with your complete name, street address, email address and phone number where you can be reached during business days, your RMA number, a list of the included items, method of payment for any non-warranty expenses and a brief summary of the problem. Your original sales receipt must also be included for warranty consideration. Be sure your name, address, and RMA number are clearly written on the outside of the shipping carton.

Warranty Inspection and Repairs

To receive warranty service, you must include your original sales receipt verifying the proof-of-purchase date. Provided warranty conditions have been met, your Product will be repaired or replaced free of charge. Repair or replacement decisions are at the sole discretion of Horizon Hobby.

Non-Warranty Repairs

Should your repair not be covered by warranty the repair will be completed and payment will be required without notification or estimate of the expense unless the expense exceeds 50% of the retail purchase cost. By submitting the item for repair you are agreeing to payment of the repair without notification. Repair estimates are available upon request. You must include this request with your repair. Non-warranty repair estimates will be billed a minimum of 1/2 hour of labor. In addition you will be billed for return freight. Please advise us of your preferred method of payment. Horizon accepts money orders and cashiers checks, as well as Visa, MasterCard, American Express, and Discover cards. If you choose to pay by credit card, please include your credit card number and expiration date. Any repair left unpaid or unclaimed after 90 days will be considered abandoned and will be disposed of accordingly. Please note: non-warranty repair is only available on electronics and model engines.

United States:

Electronics and engines requiring inspection or repair should be shipped to the following address:

Horizon Service Center
4105 Fieldstone Road
Champaign, Illinois 61822
USA

All other Products requiring warranty inspection or repair should be shipped to the following address:

Horizon Product Support
4105 Fieldstone Road
Champaign, Illinois 61822
USA

Please call 877-504-0233 or e-mail us at productsupport@horizonhobby.com with any questions or concerns regarding this product or warranty.

United Kingdom:

Electronics and engines requiring inspection or repair should be shipped to the following address:

Horizon Hobby UK
Units 1-4 Ployters Rd
Staple Tye
Harlow, Essex
CM18 7NS
United Kingdom

Please call +44 (0) 1279 641 097 or e-mail us at sales@horizonhobby.co.uk with any questions or concerns regarding this product or warranty.

Germany:

Electronics and engines requiring inspection or repair should be shipped to the following address:

Horizon Technischer Service
Hamburger Strasse 10
25335 Elmshorn
Germany

Please call +49 4121 46199 66 or e-mail us at service@horizonhobby.de with any questions or concerns regarding this product or warranty.

CE Compliance Information for the European Union

Instructions for Disposal of WEEE by Users in the European Union

This product must not be disposed of with other waste. Instead, it is the user's responsibility to dispose of their waste equipment by handing it over to a designated collection point for the recycling of waste electrical and electronic equipment. The separate collection and recycling of your waste equipment at the time of disposal will help to conserve natural resources and ensure that it is recycled in a manner that protects human health and the environment. For more information about where you can drop off your waste equipment for recycling, please contact your local city office, your household waste disposal service or where you purchased the product.

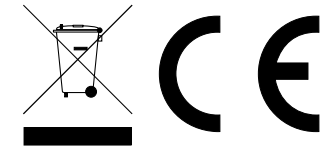

Declaration of Conformity

(in accordance with ISO/IEC 17050-1)

No. HH2009102201

Product(s): DYN 1/10th Brushless ESC,
DYN 1/18 Mini Brushless
ESC

Item Number(s): DYN3741, DYN3740

Equipment class: 1

The object of declaration described above is in conformity with the requirements of the specifications listed below, following the provisions of the European EMC Directive 2004/108/EC:

EN55022 Radio disturbance characteristics

EN55024 Immunity characteristics

EN 61000-4-2 Electrostatic discharge immunity test

Signed for and on behalf of:

Horizon Hobby, Inc.

Champaign, IL USA

Oct 22, 2009

Steven A. Hall

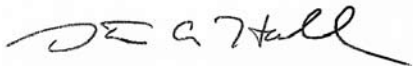

Vice President

International Operations and Risk Management

Horizon Hobby, Inc.

© 2009, Horizon Hobby, Inc.
4105 Fieldstone Road
Champaign, Illinois 61822
U.S.A.
(877) 504-0233
www.horizonhobby.com

Distributed exclusively by Horizon Hobby Inc.