

Name: <u>Adam Drake</u>		Date: <u>10-6-13</u>	Event: <u>Southern Nats.</u>
City: <u>West Monroe</u>		State: <u>LA.</u>	
Track: <u>Southern Nats.</u>			
Track Conditions	<input checked="" type="checkbox"/> Indoor <input type="checkbox"/> Tight <input type="checkbox"/> Smooth <input type="checkbox"/> Hard Packed <input type="checkbox"/> Blue Groove	<input type="checkbox"/> Wet <input checked="" type="checkbox"/> Low Bite <input type="checkbox"/> High Bite	
	<input type="checkbox"/> Outdoor <input checked="" type="checkbox"/> Open <input checked="" type="checkbox"/> Rough <input type="checkbox"/> Loose/Loamy <input type="checkbox"/> Dry	<input type="checkbox"/> Dusty <input type="checkbox"/> Med Bite <input type="checkbox"/> Other _____	

Front Suspension

Toe: 1 degree out

Ride Height: 29mm

Camber: -1 degree

Caster: 27 degrees

Wheel Hex: stock (0)

Sway Bar: 2.3mm

Piston/Oil: 1.3 tapered - 40wt

Spring: Silver - 4.6

Limit/Droop: 103.5mm

Overall Shock Length: _____

Steering Ackerman: long

Bump Steer: up - 3mm spindle

Camber Link: 1

Shock Location: 1 - outside

Receiver Battery Type: DYN1419

Differentials

Front: Standard Smart

Spring Wire Dia: _____

Qty of Springs: _____

Ramp Plate: _____

Grease: _____

Diff Fluid: 5,000

Center: Standard Smart

Spring Wire Dia: _____

Qty of Springs: _____

Ramp Plate: _____

Grease: _____

Diff Fluid: 7,000

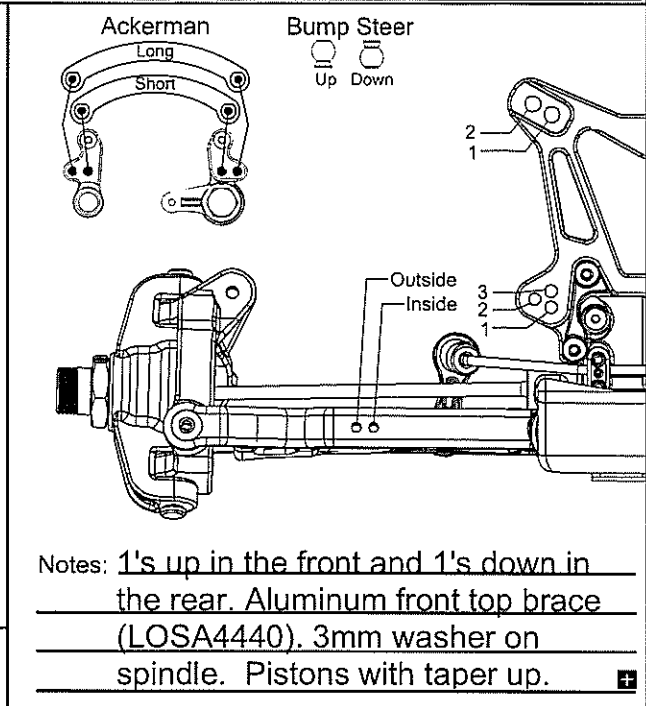

Rear Suspension

Roll Center: HRC LRC

Toe: 3 degrees

Anti-Squat: 3 degrees

Ride Height: 29mm

Camber: -2 degrees

Rear Hub Spacing: back

Wheel Hex: 1mm

Sway Bar: 2.3mm

Piston/Oil: 1.3x1.2 tapered - 35wt

Spring: Silver

Limit/Droop: 114mm

Overall Shock Length: _____

Camber Link: 1-B

Shock Location: 2 - outside

Rear Diff Fluid: 3,000

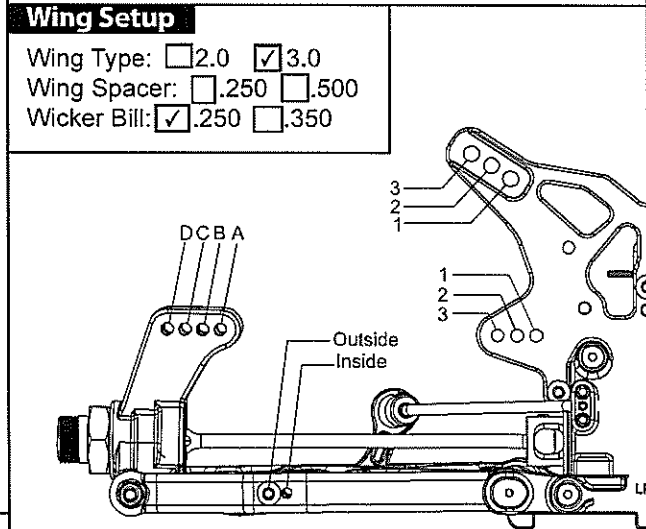

Engine

Engine: Nova Rossi Keep Off Fuel: Nitrotane 30%

Glow Plug: C6TGC Head Clearance: 08mm

Pipe/Header: 9901/41021 Gearing: 13/48

Clutch

Clutch Shoes and Springs Info

2 carbon with black springs and 2 aluminum with green springs. Steel flywheel.

Tires

	Type	Compound	Insert
Front:	<u>Blockade</u>	<u>M4</u>	<u>Pro-Line</u>
Rear:	<u>Blockade</u>	<u>M4</u>	<u>Pro-Line</u>
Notes:	<u>Holeshot 2.0's for qualifying.</u>		