

NT/NX Evolution® Engines

USER GUIDE



© 2006 Manufactured exclusively for Horizon Hobby, Inc. 877-504-0233

www.horizonhobby.com

9155



Introduction

Congratulations on your purchase of the newest and one of the most technically advanced 2-stroke model airplane engines in the world. Whether you are new to the sport of model aviation or an experienced flyer, you will enjoy the features of the new Evolution® Engines NT/NX Engine.

The Evolution NT/NX Engine is designed to be the most powerful in its class, extremely easy to start and operate, and provide years of enjoyable service. It incorporates many unique design features, such as our Set Right™ needle valve assemblies. Every feature is designed to ensure success with your new engine.

This user's guide is intended to provide the basic information to operate and maintain your Evolution NT/NX Engine.

Every Evolution Engine has been test run and adjusted at the factory and is ready to fly with no adjustments or break-in required.

Important: While the Evolution Engine is extremely easy to operate, if this is your first experience flying a model airplane, it is highly recommended that you have the help of an experienced modeler during the first few flights. Your local hobby shop or flying club can put you in touch with an experienced pilot in your area.

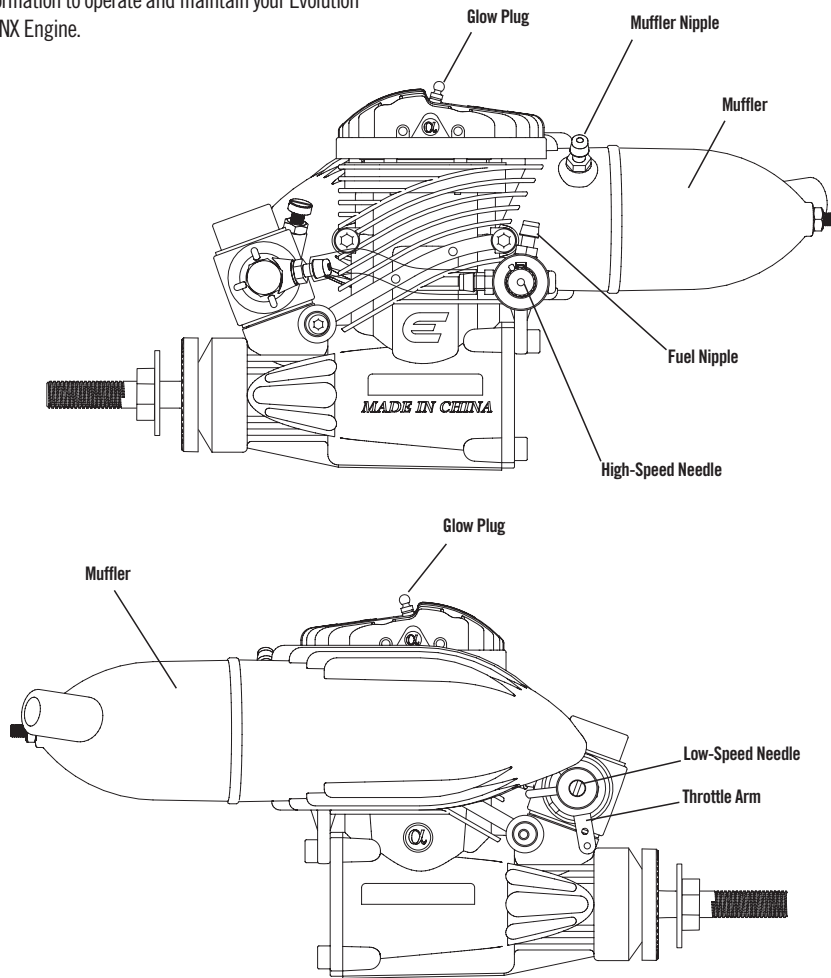

Mounting the Engine



Securely tighten all engine mounting screws and re-check tightness before each flying session.

Most model airplanes include an engine mount. It is extremely important that the engine mount be securely mounted to the airplane's firewall and that the engine is securely mounted to the engine mount. Follow the instructions included with the airplane for mounting the engine.

Important: Before each flying session, check that all engine mounting screws are securely tightened.

Installing the Muffler



The muffler mounting accessory package includes mounting screws (2), lock washers (2), muffler gaskets (2) and an L-wrench.



Using the included muffler mounting screws and lock washers, attach the muffler with the included hex wrench. Be sure the lock washers are placed over the screws and that one gasket is placed between the muffler and the engine. A second gasket is included as a spare. Securely tighten both screws with moderate torque.

Important: After five runs, retighten the muffler mounting screws. Heat and vibration from these first few runs can cause the gasket to compress. Once the muffler screws are re-tightened, they will remain tight and leak-free until the muffler is removed.

Throttle Linkage

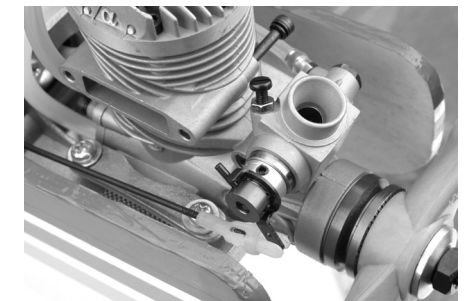

Attach the linkage to the throttle arm.

A clevis is recommended for attaching the throttle linkage to the throttle. Attach the throttle linkage to the hole in the throttle arm (see photo above). Turn on the radio. With the throttle stick at 1/2 throttle, install the arm on the servo so that the arm is 90° to the throttle pushrod.

Select a servo arm that has a hole located 11mm or 7/16" out from center and attach the other end of the throttle linkage. (see photos below)

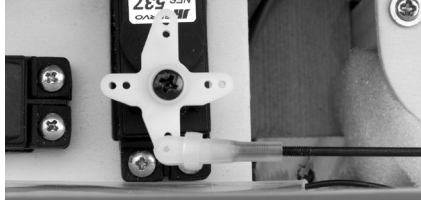

Linkage 11mm out



1/2 throttle

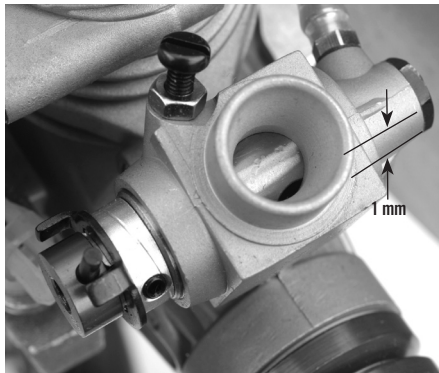

At low throttle, mid-trim, the throttle barrel should be 1 mm open.

With low throttle and mid-trim (idle position), the throttle barrel should be open 1mm, giving a low rpm idle (see photo above). Adjust the length of the pushrod until the throttle barrel is exactly 1mm open. Check to be sure the servo is moving in the correct direction. Full throttle should open the throttle barrel fully, while low throttle, low-trim should completely close the throttle barrel. Reverse the servo throw if necessary.

Note: It may be necessary to slightly adjust the length of the throttle pushrod to achieve the correct mid-trim, low-stick idle position.

Attaching the Fuel Lines

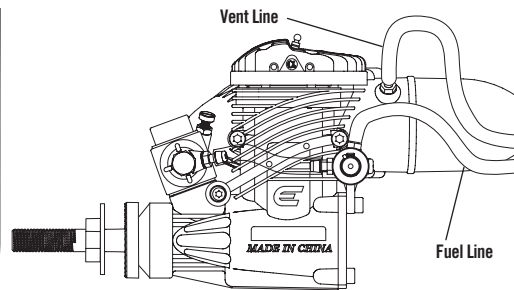
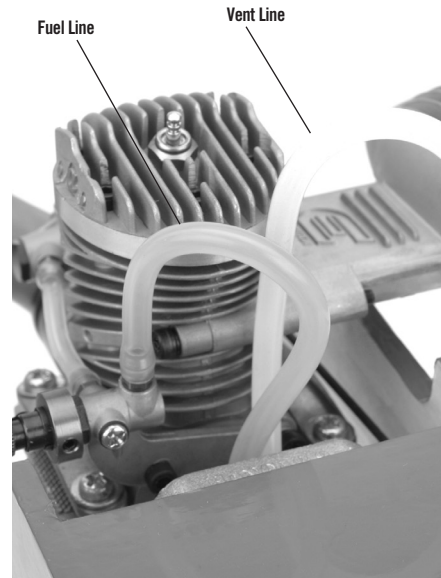

Using medium silicon fuel tubing, attach the fuel tank's clunk line to the fuel nipple. This line will supply fuel to the engine. Attach the vent line to the muffler pressure nipple. This line pressurizes the fuel tank with the muffler pressure, creating consistent fuel flow, regardless of the airplane's altitude.

Attaching the Propeller and Spinner

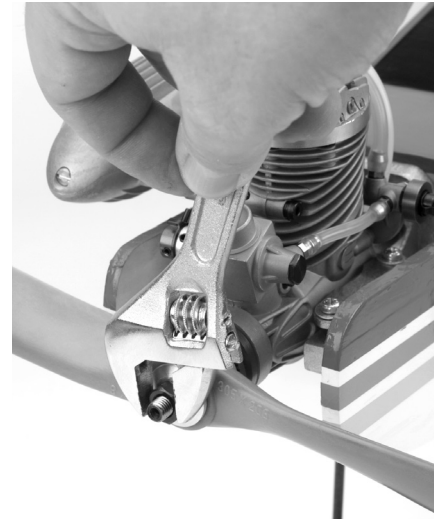

Securely tighten the prop nut using an adjustable wrench.



Remove the prop nut and prop washer from the engine. Install the spinner back plate. Install the propeller, the prop washer and then the prop nut in that order (see photo). Securely tighten the prop nut using an adjustable wrench. Install the spinner cone.

Starting the Evolution Engine

Fuel

The Evolution Engine comes pre-run and adjusted from the factory. We recommend using high quality Cool Power Omega, Hangar 9® AeroBlend™ or Power Master fuels containing 10 to 15% Nitro. The Evolution Engine has been test run using these fuels. If another brand of fuel is used, it may be necessary to slightly adjust the needle valves to compensate for the differences in fuel.

Glow Plug

The Evolution Engine comes with a specially designed "Super Plug" that prevents idle and transition flameouts. The plug's unique shape directs incoming fuel/air mixture away from the plug element. When replacing the plug, be sure to replace it with another Hangar 9 Super Plug (HAN3011).

Starting the Engine

- Step 1.** Fill the tank with the above-mentioned 10 or 15% fuel.
- Step 2.** Reattach the fuel lines, making sure the vent and clunk line are attached to the fuel nipple and the muffler pressure nipple.
- Caution:** Do not attach the glow driver yet.
- Step 3.** With the throttle fully open, place your thumb over the carburetor and rotate the prop clockwise through 6 complete revolutions, thus priming the engine.
- Step 4.** Close the throttle to the idle position and have a helper hold your airplane.



The Hangar 9 START KIT (HANSTART) includes everything needed, except fuel and starter, to get the Evolution Engine running.

Step 5. Attach the glow driver.

Step 6. Turn the engine over using an electric starter.
The engine should fire within seconds of applying the starter.

Step 7. Allow the engine to idle for 30 seconds. Adjust the throttle trim if necessary to achieve a constant slow idle.

Step 8. With the glow driver still attached and a helper securely holding the airplane, advance the throttle smoothly to full throttle. The engine will transition to full rpm.

Step 9. Reduce the throttle to idle and remove the glow driver.

Needle Limiters

In some conditions: Due to high altitudes, extreme temperatures, etc., it may be necessary to slightly adjust the idle and high-speed needle valves. The high- and low-speed needles have limiters that prevent over adjustment.



If your engine starts from the above procedure, but won't reliably continue to run with the glow driver removed, follow the steps above right.

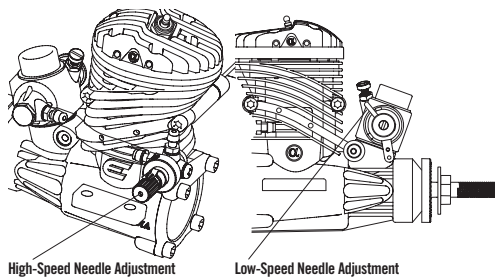

The needle valves come preset from the factory. Extreme conditions may require some minor adjustments. Note that the needle adjustment range is limited, preventing adjustment beyond the practical range.

Step 1. High-Speed Needle Adjustment

With the engine running, advance the throttle to full throttle while a helper securely holds your airplane. Carefully pinch and release the fuel line to temporarily restrict the fuel flow.

Caution: Do not reach over the propeller while the engine is running.

Correct: If the high-speed needle adjustment is correct, the engine will increase rpm slightly (about 300 rpm) and then die.

Too Rich: If the engine increases a lot (1,000 rpm or greater), the high-speed needle is too rich and must be leaned or turned clockwise.

Too Lean: If the engine doesn't increase rpm and simply dies, the high-speed needle is lean and must be richened or turned counterclockwise.

Step 2. Low-Speed Needle Adjustment

The low-speed or idle needle valve, included with the SetRight™ assembly, is preadjusted at the factory for best performance. It may be necessary to fine-tune the low-speed adjustment using the following procedure:

1. Start the engine and let it warm up, prior to attempting any adjustments. Make sure that the high-speed adjustment process is complete before attempting to adjust the low-speed needle valve.

2. Close the throttle slowly. You will adjust the low-speed needle setting by rotating the SetRight adjustment bar clockwise to lean the engine and counterclockwise to richen the engine.

Caution: Do not attempt to adjust the low-speed needle valve while the engine is running.

3. The fuel mixture should be adjusted as follows: The fuel mixture is too rich if, when opening the throttle rapidly, the engine emits smoke and "stutters" or "stumbles." Correct this by rotating the SetRight adjustment bar clockwise in small increments. Continue this process until the engine transitions smoothly from low rpm idle to high rpm without hesitation upon opening the throttle rapidly.

Step 2. Low-Speed Needle Adjustment, cont.

4. The fuel mixture may be too lean if the engine stops at the lowest idle position or it stops when the throttle is rapidly opened from the idle position. Correct this by rotating the SetRight™ adjustment bar counterclockwise in small increments until the engine transitions smoothly without hesitation upon opening the throttle rapidly from idle.

SetRight Needle Valves

The design of the SetRight needle valve system is such that, during normal operating conditions, the typical user will find that the range of adjustment allowed by the system is more than adequate for most situations. As a matter of fact, we intended this to be used as a tool to identify operating problems. If you find that the range of adjustment allowed by the SetRight needle is inadequate after your initial period of running, then a problem in your engine system has occurred. This might be a bad glow plug, dirty or old fuel, an air leak in the fuel system somewhere or any number of other reasons. Do not make any permanent adjustment range changes to the SetRight needle system if it was once working correctly for you and now does not. Investigate other problems first.

However, occasionally due to atmospheric, altitude or fuel conditions, you may find that the range of adjustment built into the SetRight needle valve system is inadequate for your needs. These conditions are rare and easy to fix.

High-Speed SetRight Needle Valve Correction

Should the high-speed SetRight needle valve need to be adjusted outside of the factory-established parameters, simply pull out the detent spring on the high-speed needle assembly and move the needle valve in the desired direction so the SetRight pin passes the spring detent. You now have re-established a new range for your purposes.

Low-Speed SetRight Needle Valve Correction

Should the low-speed SetRight needle valve need to be adjusted outside the factory-established parameters, follow these steps:

A. Loosen the setscrew found on the ring of the SetRight assembly to which the adjustment bar is attached.

Low-Speed SetRight Needle Valve Correction, cont.

B. Rotate the needle valve itself (small slot-headed screw inside the blue ring of the SetRight assembly) clockwise to lean the mixture or counterclockwise to richen the mixture as desired.

C. Retighten the setscrew on the ring of the SetRight assembly and you have re-established a new range of motion.

Why would fuel go "bad"?

The largest portion of the fuel is methanol (alcohol). Methanol is hygroscopic; it attracts moisture. This can cause your fuel to be contaminated with water, which will cause poor engine performance. Additionally, the UV rays in sunlight will eventually break down the nitromethane if the fuel jug is stored in sunlight for long periods of time.

How can you tell when your fuel has gone "bad"?

The first indications will generally be the inability to start the engines at previously run needle-valve settings. Another clue might be that the engine has very poor idle, runs but bogs down tremendously during run up and/or will not attain the same rpms that you are used to.

How do I keep my fuel fresh?

If you have the opportunity, look for someone at a flying field on a sunny day who has a jug of fuel that is only 1/4 full. What you may notice is that there are droplets attached to the top and sides of the container. This is the moisture in the air that is condensing inside the jug because of the greenhouse effect of the semi-translucent plastic jug. The only way to overcome the greenhouse effect is to store your fuel in a metal can.

You can also combat the effects of the moisture in the air by squeezing all the extra air from your fuel container at the end of the day or transferring your fuel into smaller containers as the level of the fuel is reduced in your gallon jug. Many pilots will invest in 1/2 gallon or quart-size containers and only bring that amount of fuel to the field on any given day. This allows their main supply of fuel to stay at home in a controlled storage environment, virtually insuring problem-free fuel.

How to tell if your glow plug is bad

The glow plugs on the market today are designed to provide good service to the user and may last a long time or a short time, all dependent upon the way you choose to operate your engine.

Physical indications that you might need to change the glow plug are:

1. Twisted or mangled glow plug element (usually caused by too high a compression ratio).
2. Small "bumps" are attached to the glow plug element. This will generally be most noticeable during the break-in process. These are actually tiny pieces of aluminum that have attached to the element and these will severely hinder the operation of the glow plug.
3. The glow plug element is no longer shiny but is dull, almost a white powder color. (This just comes with age and is a by-product of the catalytic reaction.

The shinier the wire, the better the catalytic reaction can be).

Operating indications that you need to change your glow plug are:

1. The glow element will not light with a charged glow igniter. This indicates that there is a physical short or breakage in the element wire itself.
2. Glow plug lights but the engine will not continue running once the battery is disconnected. (This is usually an indication of the microscopic particles we discussed earlier).
3. Glow plug lights, engine runs but there is a perceptible loss of rpm at full throttle when the battery is disconnected. This is a typical indication that the white powder residue is building to the point that the catalytic reaction of the glow plug is no longer anywhere close to being optimum.

NT/NX Evolution® Engines Specifications

Items	Disp (c.i.)	Bore (mm)	Stroke (mm)	Weight (oz)	Crank K (ISO)	Cylinder	Propeller
EVOE0360	.354"	.806"	.695"	10.3	1/4X28	ABC	9X6
EVOE100	.455"	.867"	.771"	16.32	1/4X28	ABC	EVOE100P
EVOE0400	.392"	.805"	.771"	14.08	1/4X28	ABC	10X6
EVOE0460	.467"	.864"	.797"	13.76	1/4X28	ABC	11X6
EVOE0520	.520"	.882"	.847"	14.72	1/4x28	ABC	11X6
EVOE0610	.608"	.944"	.862"	20.1	5/16 X 24	ABC	12X6
EVOE1100	1.005"	1.14"	.985"	23.2	5/16X24	ABC	14X6

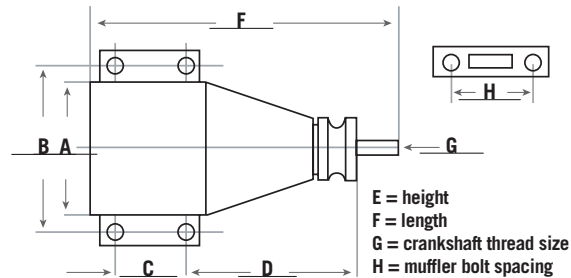

Dimensions(mm)	A	B	C	D	E	F	G	H
EVOE0360	30	38	15	47	78	108	1/4X28	37
EVOE100	36	44	17.5	52.5	90.5	108	1/4X28	37
EVOE0400	36	44	17.5	52.5	90.5	108	1/4X28	37
EVOE0460	36	44	17.5	52.5	90.5	108	1/4X28	37
EVOE0520	36	44	17.5	52.5	94	110	1/4X28	37
EVOE0610	42	55	25	55	100	133	5/16x24	42
EVOE1100	44	52	25	64.6	92	139.7	5/16x24	42

Troubleshooting Guide

Engine Won't Fire

- Glow starter not charged
 - Charge glow starter
- Glow plug burnt out
 - Replace glow plug
- No fuel is getting to the carburetor
 - Check tank, fuel lines reversed
- The starter is reversed
 - Reverse the polarity on the starter cables

Engine Quits Repeatedly

- Needles need adjusting
 - See adjustment procedure
- Bad or old fuel
 - Replace with fresh fuel
- Worn out glow plug
 - Replace with new HAN3006 super plug

Engine Runs Inconsistently

- Hole in fuel line
 - Replace fuel line
- Bad or old fuel
 - Replace with fresh fuel

Maintenance

After each flying session:

1. Fully drain the fuel from the tank.
2. Start the engine and run it until the fuel is completely run out of the engine.
3. Try starting the engine three more times or until it will no longer fire. This gets all the fuel out of the engine.

If the engine will not be used within 10 days, several drops (about 10) of after run oil (Evolution Engine's Blue Block Rust Inhibitor) should be applied into the carburetor and the engine should be turned over for a few seconds with the starter. This will prevent rust and corrosion.

If you need additional help or have any questions, please call Horizon's Service Center. Horizon has trained technicians who are qualified to answer your engine questions.

Evolution/Horizon Service Center

4105 Fieldstone Road
Champaign, IL 61822
877-504-0233

Evolution® Engines 2-Year Warranty

This Evolution Engines product is guaranteed to be free from defects in materials and workmanship for a period of 2 years from the date of purchase by the original owner. This warranty is not transferable. Horizon Hobby reserves the right to inspect any and all equipment involved in a warranty claim. Repair or replacement decisions are also determined by Horizon Hobby, Inc. Collateral damage of any type is not covered under this warranty.

This warranty does not cover any component parts damaged or changed by modification. In no case shall Horizon Hobby or Evolution Engines liability exceed the original cost of the engine.

This warranty does not apply to wear from normal use; damage or defects resulting from misuse, neglect or abuse; damage caused by customer disassembly, use of substandard fuel, use of incorrect accessories (spark plug, propeller, etc.); or damage resulting from a crash, or any use of this engine other than for which it is specifically intended. Any of the above will automatically void the warranty of the engine.

In that Horizon Hobby has no control over the final installation and use of this product, the materials used in installation, or the product in which this engine is installed, no liability shall be assumed nor accepted for

any damage resulting in the use of this product once it is installed. By the act of using the installed product, the user accepts all resulting liability. If the buyer is not prepared to accept the liability associated with the installation and/or use of this product, the buyer is advised to return the engine immediately in new and unused condition to the place of purchase.

Should your engine require warranty or non-warranty repair service, please package it carefully and return it to the address below, along with a copy of the original invoice or receipt and a detailed letter explaining the problems. Write your name, address and daytime phone number clearly on the letter and return it via FedEx, UPS or insured Parcel Post (Evolution Engines will not be responsible for product lost en route).

For repairs not covered under warranty, please specify in your letter whether you want an estimate of the repair charges prior to performing the service (which may cause a slight delay). Payment for non-warranty repairs should be made by credit card or money order. If you have any questions concerning this or other Evolution products please contact the Horizon Product Support Team at 877-504-0233.

Evolution/Horizon Service Center
4105 Fieldstone Road, Champaign, IL 61822
877-504-0233
productsupport@horizonhobby.com

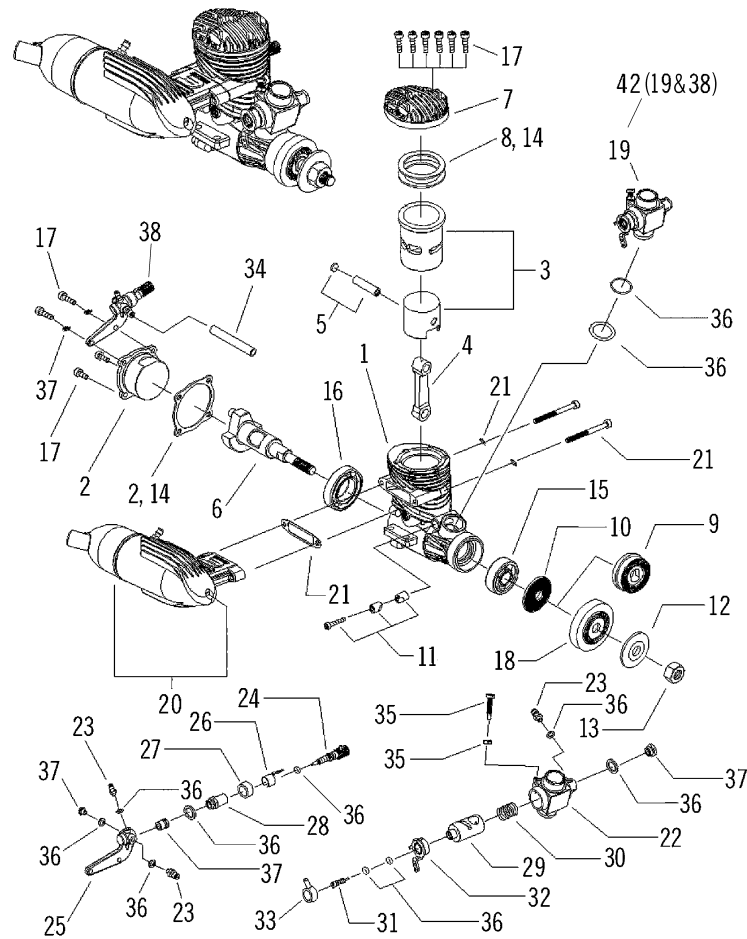

No.	Description	No.	Description
1	Crankcase	20	Muffler
2	Rear Cover with Gasket	21	Muffler Mounting Screw Set
3	Piston & Liner Set (ABC)	22	Carburetor Body
4	Connecting Rod (Dual Bushing)	23	Fuel Nipple
5	Wrist Pin w/Clips (Teflon)	24	High-Speed Needle Valve
6	Crankshaft (1/4 X 28)	25	Spraybar Bracket (Remote)
7	Cylinder Head (Evolution)	26	High-Speed Needle Valve Ratchet
8	Cylinder Head Shim	27	Collar w/Set Screw
9	Prop Driver	28	Spraybar, (Remote)
10	Spacer Washer	29	Throttle Barrel
11	Carburetor Retainer (Drawbar)	30	Throttle Barrel Spring
12	Prop Washer	31	Idle Needle
13	Prop Nut (1/4 X 28)	32	Throttle Arm
14	Gasket Set, Engine	33	Idle Needle Limit Collar
15	Ball Bearing, Front (Rubber Seal)	34	45mm Fuel Tube
16	Ball Bearing, Rear (Open Race)	35	Idle Needle Stop Screw w/Nut
17	Screw Set, Engine	36	Carburetor Gasket, O-Ring Set
18	Flywheel (Evo-Alpha)	37	Small Parts Set, Carburetor
19	Carburetor, Complete	38	Needle Valve Assembly

Cross-Reference of Evolution Alpha, .36NT, 40 NT, .46 NT, .52 NX, .61 NT and 1.00 NX Part Numbers

No. Description	.36NT	.40 Alpha (TPS)	.40 NT	.46 NT	.52 NX	.61 NT	1.00 NX
1 Crankcase	EVO036101	EVO100101A	EVO040101	EVO046101	EVO052101	EVO061101	EVO110101
2 Rear Cover w/Gasket	EVO032102	EVO100E46D	EVO100E46D	EVO100E46D	EVO052102	EVO061102	EVO110102
3 Piston & Liner set (ABC)	EVO036203	EVO100203	EVO040203	EVO046203	EVO052203	EVO061203	EVO110203
4 Connecting Rod Set (Dual Bushing)	EVO032204	EVO100204	EVO100204	EVO100204	EVO052204	EVO080204	EVO110204
5 Wrist Pin w/Clips (Teflon)	EVO032213	EVO100213	EVO040213	EVO040213	EVO052213	EVO061213	EVO110213
6 Crankshaft	EVO032210	EVO100210	EVO100210	EVO046210	EVO052210	EVO061210	EVO110210
7 Cylinder Head (Evolution)	EVO036103	EVO100103A	EVO040103	EVO046103	EVO052103	EVO061103	EVO110103
8 Cylinder Head Shim	EVO036112	EVO100112	EVO040112	EVO040112	EVO052112	EVO061112	EVO110112
9 Prop Driver	EVO036219	EVO100219	EVO040219	EVO040219	EVO040219	EVO061238X	EVO110219
10 Spacer Washer	EVO032225	EVO100219B	EVO100219B	EVO100219B	EVO100219B	N/A	EVO100219B
11 Carburetor Retainer (Drawbar)	EVO036129	EVO100129	EVO100129	EVO100129	EVO100129	EVO061129	EVO061129
12 Prop Washer	EVO100220	EVO100220	EVO100220	EVO100220	EVO100220	EVO061228	EVO110220
13 Prop Nut	EVO100221	EVO100221	EVO100221	EVO100221	EVO100221	EVO061228	EVO110228
14 Gasket Set, Engine	EVO036416	EVO100416	EVO040416	EVO100416	EVO052416	EVO061416	EVO110416
15 Ball Bearing, Front (Rubber seal)	EVO032109	EVO100109	EVO100109	EVO100109	EVO100109	EVO061109	EVO110109
16 Ball Bearing, Rear (Open Race)	EVO028110	EVO100110	EVO100110	EVO100110	EVO052110	EVO061110	EVO061110
17 Screw Set, Engine	EVO036901	EVO100901	EVO100901	EVO100901	EVO052901	EVOP61901	EVO110901
18 Flywheel (Evolution)	N/A	EVO100219A	N/A	N/A	N/A	N/A	N/A
19 Carburetor Complete	EVO036801	EVO100801A	EVO100801A	EVO100801A	EVO100801A	EVO061801	EVO110801
20 Muffler	EVO036601	EVO100601	EVO100601	EVO100601	EVO100601	EVO061601	EVO110601
21 Muffler Mounting Screw Set w/Gasket	EVO036E36A	EVO100E46A	EVO100E46A	EVO100E46A	EVO100E46A	EVO061E61A	EVO110E100A
22 Carburetor Body (w/spraybar)	EVO036863	EVO100863	EVO100863	EVO100863	EVO100863	EVO061863	EVO110863
23 Fuel Nipple & Gasket	EVO100114	EVO100114	EVO100114	EVO100114	EVO100114	EVO061819	EVO061819
24 High-Speed Needle Valve	EVO100829A	EVO100829A	EVO100829A	EVO100829A	EVO100829A	EVO100829A	EVO100829A
25 Spraybar Bracket (Remote)	EVO036870	EVO100870A	EVO100870A	EVO100870A	EVO100870A	EVO061870	EVO110870
26 High-Speed Needle Valve Ratchet	EVO100873	EVO100833	EVO100833	EVO100833	EVO100833	EVO100833	EVO100833
27 Collar w/Set Screw	EVO100834A	EVO100834A	EVO100834A	EVO100834A	EVO100834A	EVO100834A	EVO100834A
28 Spraybar, Remote	EVO100830	EVO100830	EVO100830	EVO100830	EVO100830	EVO100830	EVO100830
29 Throttle Barrel	EVO036813	EVO100813	EVO100813	EVO100813	EVO100813	EVO061813	EVO110813
30 Spring, Throttle Barrel	EVO100814A	EVO100814A	EVO100814A	EVO100814A	EVO100814A	EVO100814A	EVO100814A
31 Idle Needle	EVO100844A	EVO100844A	EVO100844A	EVO100844A	EVO100844A	EVO100844A	EVO110844A
32 Throttle Arm	EVO100864A	EVO100864A	EVO100864A	EVO100864A	EVO100864A	EVO100864A	EVO100864A
33 Idle Needle Limit Collar	EVO100850A	EVO100850A	EVO100850A	EVO100850A	EVO100850A	EVO100850A	EVO100850A
34 45mm Fuel Tube	EVO100872	EVO100828A	EVO100878A	EVO100878A	EVO100878A	EVO100878A	EVO100878A
35 Idle Stop Screw w/Nut	EVO100825F	EVO100825F	EVO100825F	EVO100825F	EVO100825F	EV0061837F	EVO100825F
36 Carburetor Gasket/O-Ring Set	EVO036E36B	EVO100E46B	EVO100E46B	EVO100E46B	EVO052E52B	EVO061E61B	EVO061E61B
37 Small Parts Set, Carburetor	EVO061E61C	EVO100E46C	EVO100E46C	EVO100E46C	EVO052E52C	EVO061E61C	EVO061E61C
38 Needle Valve Assembly	EVO036874	EVO046874	EVO046874	EVO046874	EVO046874A	EVO061874	EVO110874
39 Drive Key	N/A	N/A	N/A	N/A	N/A	N/A	EVO110218
40 Sleeve Index Pin	N/A	N/A	N/A	N/A	EVO400160	N/A	EVO400160
41 Propeller Washer & Nut Set	EVO040228	EVO040228	EVO040228	EVO040228	EVO040228	N/A	N/A
42 Carburetor w/Remote NV Assembly	*	*	*	*	EVO052803	EVO061803	*

