

Name: _____		Date: _____		Event: _____	
City: _____		State: _____		Track: _____	
Track	<input type="checkbox"/> Indoor	<input type="checkbox"/> Tight	<input type="checkbox"/> Smooth	<input type="checkbox"/> Hard Packed	<input type="checkbox"/> Blue Groove
Conditions	<input type="checkbox"/> Outdoor	<input type="checkbox"/> Open	<input type="checkbox"/> Rough	<input type="checkbox"/> Loose/Loamy	<input type="checkbox"/> Dry
	<input type="checkbox"/> Wet	<input type="checkbox"/> Low Bite	<input type="checkbox"/> High Bite	<input type="checkbox"/> Dusty	<input type="checkbox"/> Med Bite
			<input type="checkbox"/> Other _____		

**Front Suspension**

Toe: \_\_\_\_\_ Camber: \_\_\_\_\_

Ride Height: \_\_\_\_\_

Caster Block:  17.5  20

Spindle Height:  High  Low

Wheel Hex: \_\_\_\_\_

Sway Bar: \_\_\_\_\_

Piston: \_\_\_\_\_

Oil: \_\_\_\_\_

Shock Type:  Bladder  Emulsion  Vented

Spring: \_\_\_\_\_

Pills: A \_\_\_\_\_ B \_\_\_\_\_

Overall Shock Length: \_\_\_\_\_

Drag Link/Ackerman: \_\_\_\_\_

Bump Spindle: \_\_\_\_\_ Link: \_\_\_\_\_

Camber Link: \_\_\_\_\_

Shock Location: \_\_\_\_\_

Front Diff Fluid: \_\_\_\_\_

Front Diff Overdrive:

Receiver Battery Type: \_\_\_\_\_

Weight: \_\_\_\_\_

**Optional Parts**

Alum Servo Saver Arm

Titanium Turnbuckles

Alum Front Brace

Alum Chassis Brace

QC Engine Mount

Carbon Center Brace

Aluminum Rear Hubs

**Drive Shaft**

Front:  CVA  UNI

Rear:  CVA  UNI  DCVA

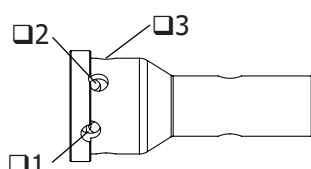

**Arm Inserts**

Front:  None  Plastic  Carbon

Rear:  None  Plastic  Carbon

**Center**

Center Diff Fluid: \_\_\_\_\_

Chassis Rib:  Aluminum  Carbon  None

Diff Case:  STD  HD

**Rear Suspension**

Shocks:  FWD  Back Shock Shaft:  3.5  4.0

Toe/D Pill: \_\_\_\_\_ Anti-Squat/C Pill: \_\_\_\_\_

D Plate:  STD  LRC

Ride Height: \_\_\_\_\_ Camber: \_\_\_\_\_

Rear Hub Spacing: \_\_\_\_\_

Hub Height:  A  B  Other

Wheel Hex: \_\_\_\_\_

Sway Bar: \_\_\_\_\_

Piston: \_\_\_\_\_

Oil: \_\_\_\_\_

Shock Type:  Bladder  Emulsion  Vented

Spring: \_\_\_\_\_

Overall Shock Length: \_\_\_\_\_ Stroke: \_\_\_\_\_

Camber Link: \_\_\_\_\_

Shock Position: \_\_\_\_\_

Rear Diff Fluid: \_\_\_\_\_

Weight: \_\_\_\_\_

**Engine**

Engine: \_\_\_\_\_ Fuel: \_\_\_\_\_

Glow Plug: \_\_\_\_\_ Head Clearance: \_\_\_\_\_

Pipe/Header: \_\_\_\_\_ Gearing: \_\_\_\_\_

**Clutch**

Clutch Shoes and Springs Info

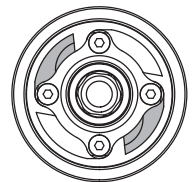

\_\_\_\_\_

\_\_\_\_\_

\_\_\_\_\_

\_\_\_\_\_

**Tires**

Type	Compound	Insert
Front: _____	_____	_____
Rear: _____	_____	_____
Notes: _____		
_____		
_____		

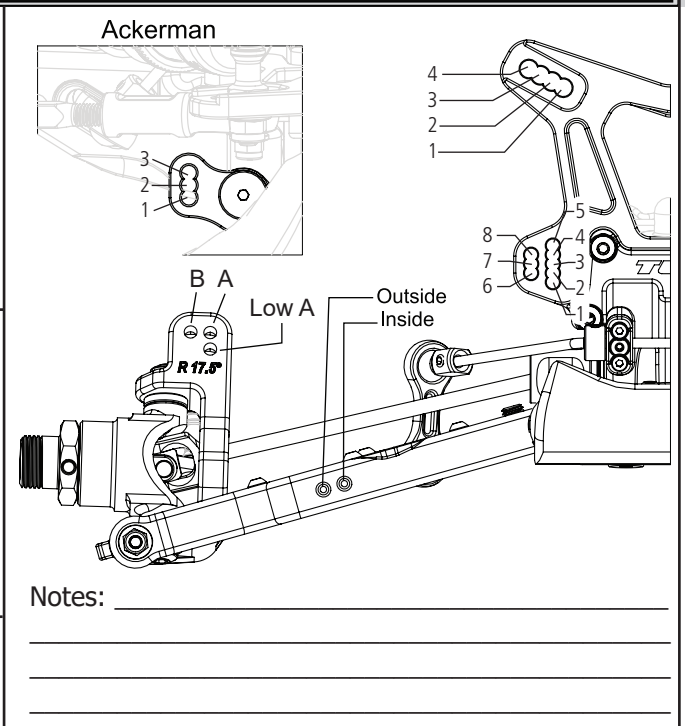

**Wing Setup**

Wing Type: \_\_\_\_\_

Wicker Bill:  .250  .350

Wing Spacer: \_\_\_\_\_

Front Wing:

